

A **Nidec** Group Company

SHIMPO

All for dreams

For servo motor

Reducer

ABLE REDUCER

EVS series

EVB series

EVL series

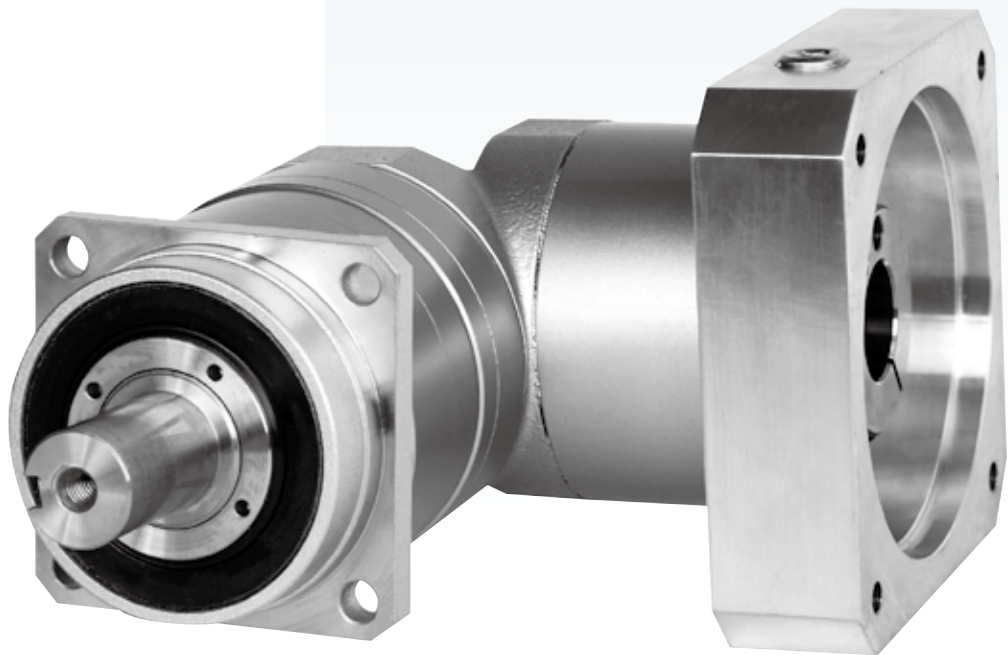

NIDEC-SHIMPO CORPORATION

Future Creation of Richer Industries - For Ceaseless Development

NIDEC-SHIMPO developed and released Ringcone CVT equipped with an independent transmission in 1952. NIDEC-SHIMPO has continued to develop products meeting customer needs and produce new products on the basis of driving technology of reducers, etc. as well as advanced electronic technology and software development. NIDEC-SHIMPO's technical testing and reliability have been proven through the award of many prizes by the Japanese Machinery Society, including the National Invention Award. NIDEC-SHIMPO will offer ideal technologies and products by exactly meeting market demand for future development in various industries.



Reducer

Reducers and transmissions are essential as driving parts within factory automation robots, machine tools, or conveyor systems.



Measuring instrument

Tester

Used to measure "Strength" of all kinds necessary for R&D or QC, e.g. tensile strength, compression strength, switching strength, etc.



Transmission

RX CVT that was successfully developed in Japan with the first independent transmission.

Reducer & transmission

Measuring instruments

PRODUCTS

FA Machinery

Ceramic devices

Others



electric potter's wheel

NIDEC SHIMPO is also the largest maker in ceramic machinery. It commercialized the first motor-driven pottery wheel in the world, showing market share of 80% home and 40% overseas. Besides, NIDEC SHIMPO is manufacturing and selling various ceramic products including electric kiln, positioning as top brand of total maker.

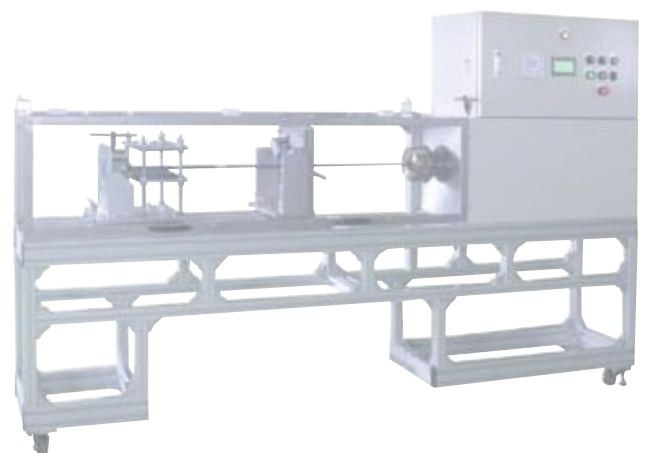

FA machinery and testers equipped with operating or measuring technology are the major fields of SHIMPO.

EVS series

High moment load type with high-precision



Can be mounted from the reducer side.

Features	EV2
Model number	EV3
Performance table	EV4
Dimensions	EV8
Dimensions (Adapter)	EV16
Installation	EV62

EVB series

High precision type



Can be mounted from the reducer side.

Features	EV22
Model number	EV23
Performance table	EV24
Dimensions	EV28
Dimensions (Adapter)	EV36
Installation	EV62

EVL series

General-purpose type



Can be mounted from the customer's machine side.

Features	EV42
Model number	EV43
Performance table	EV44
Dimensions	EV48
Dimensions (Adapter)	EV56
Installation	EV62

Applications

■ Printer

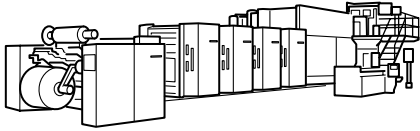

■ Gantry robot

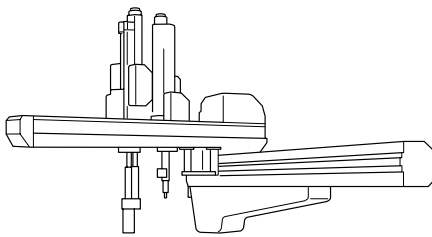

■ Packing machine(vertical pillow)

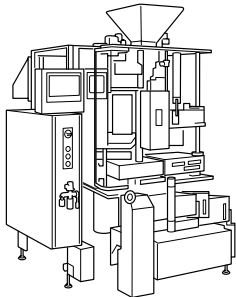

■ Dispenser robot

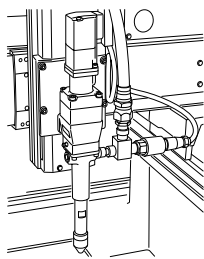

■ Turret head

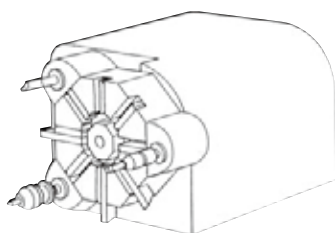

■ Conveyer-belt

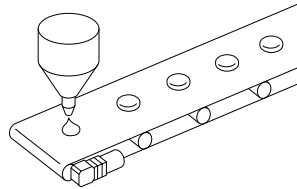

■ Auto packing sealing machine

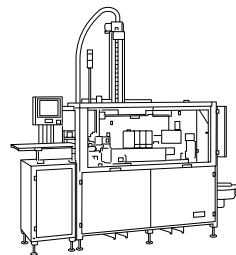

■ Packing machine(horizontal pillow)

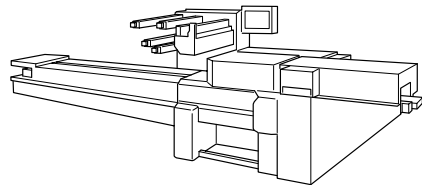

■ Loader robot

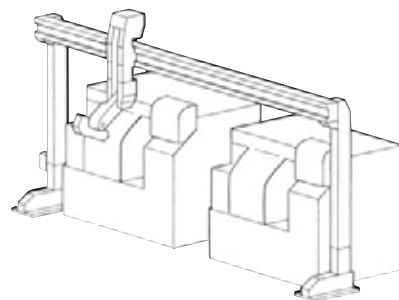

Attachable and applicable to a range of applications and devices

SHIMPO

For servo motor

ABLE REDUCER

EVS Series

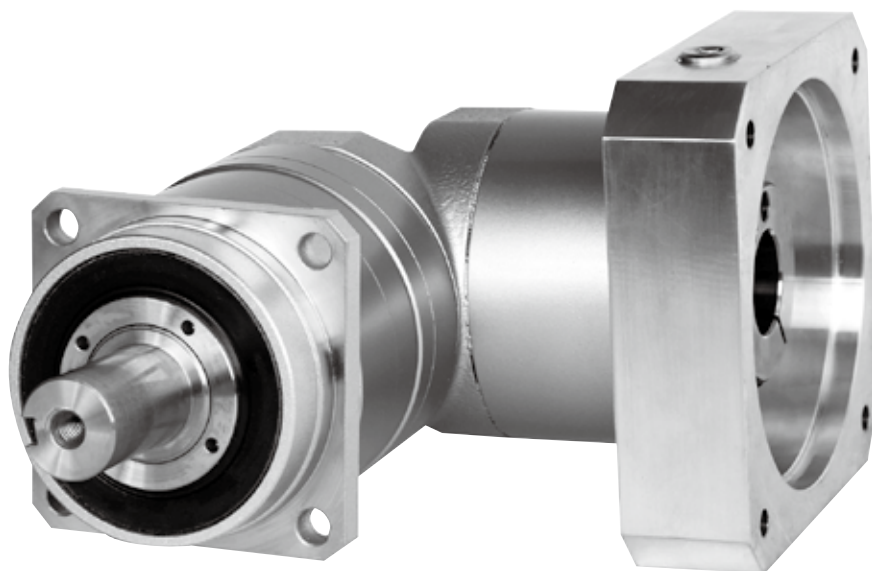

EVS series

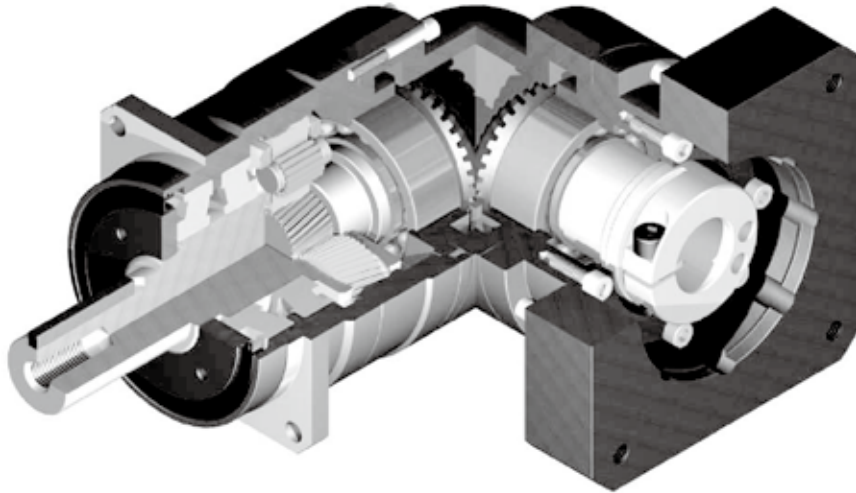

Space - saving

Right angle reducer using spiral bevel gear
Customer can locate the motor at 90 degree away from the reducer if required to save space.

High rigidity & torque

High rigidity & high torque was achieved by uncaged needle roller bearings.

High load capacity

Adopting taper roller bearing for the main output shaft to increase radial and axial load.

Adapter-bushing connection

Can be attached to any motor all over the world.

No grease leakage

Perfect solution by high viscosity anti-separation grease.

Maintenance-free

No need to replace the grease for the life time.
Can be attached in any position.

EVS series

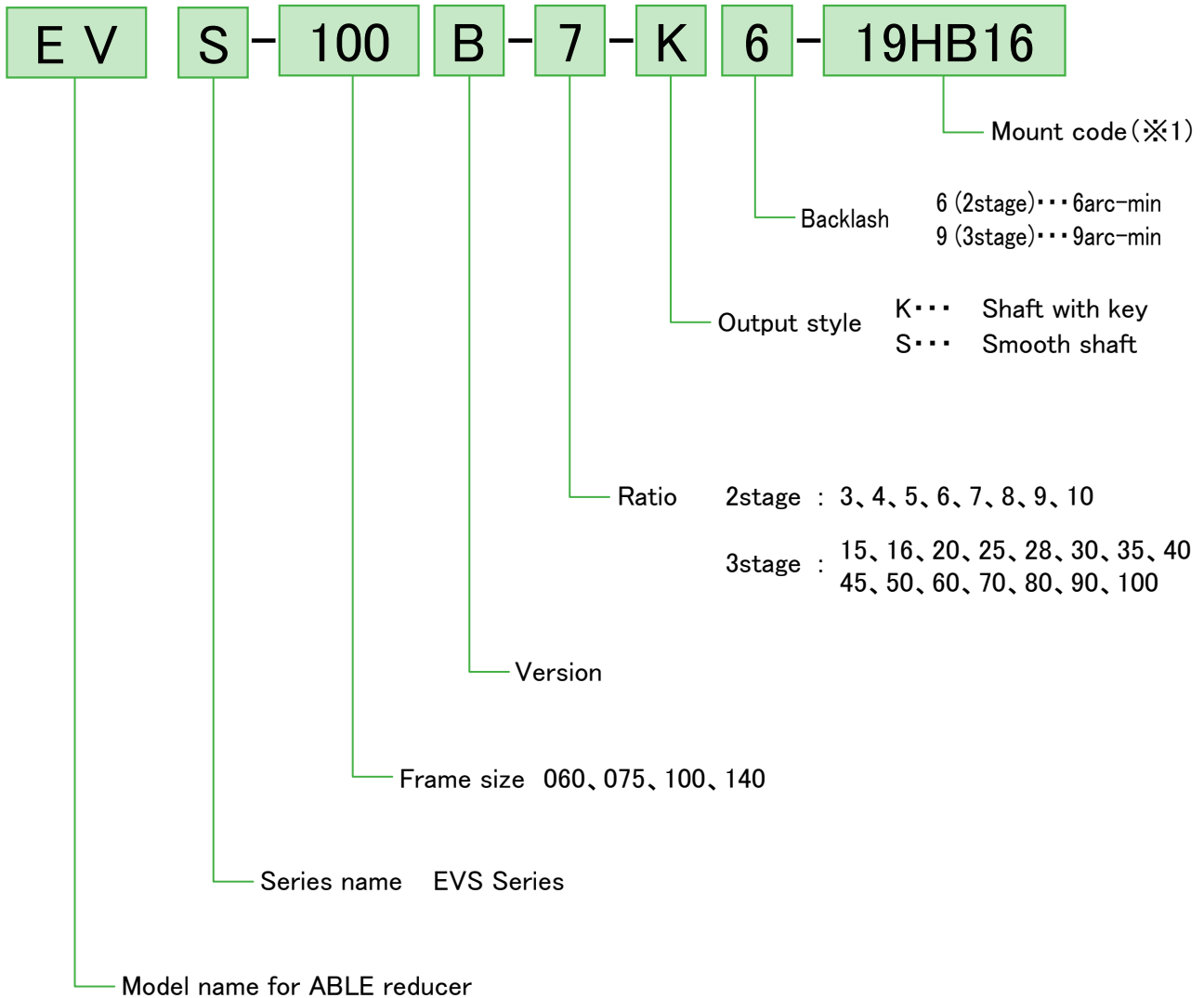

※1 Mount code

Mount code varies depending on the motor.

Please refer to reducer selection tool or contact us for more information.

Selection tool (English)

(<http://www.nidec-shimpo.co.jp/selection/eng/>)

EVS-060B

Frame size	Stage	Ratio	※1	※2	※3	※4	※5	※6	※7
			Nominal output torque [Nm]	Maximum output torque [Nm]	Emergency stop torque [Nm]	Nominal input speed [rpm]	Maximum input speed [rpm]	Permitted radial load [N]	Permitted axial load [N]
060B	2	3	12	24	50	3000	6000	1700	2300
		4	16	32	65	3000	6000	1900	2500
		5	22	40	80	3000	6000	2000	2700
		6	24	45	90	3000	6000	2100	2700
		7	24	45	90	3000	6000	2200	2700
		8	24	45	90	3000	6000	2300	2700
		9	16	32	65	3000	6000	2400	2700
	3	10	16	32	65	3000	6000	2400	2700
		15	16	32	65	3000	6000	2800	2700
		16	24	45	90	3000	6000	2800	2700
		20	24	45	90	3000	6000	3000	2700
		25	24	45	90	3000	6000	3000	2700
		28	24	45	90	3000	6000	3000	2700
		30	16	32	65	3000	6000	3000	2700
		35	24	45	90	3000	6000	3000	2700
		40	24	45	90	3000	6000	3000	2700
		45	16	32	65	3000	6000	3000	2700
		50	24	45	90	3000	6000	3000	2700
		60	24	45	90	3000	6000	3000	2700
		70	24	45	90	3000	6000	3000	2700
80	24	45	90	3000	6000	3000	2700		
90	16	32	65	3000	6000	3000	2700		
100	16	32	65	3000	6000	3000	2700		

Frame size	Stage	Ratio	※8	※9	※10	Moment of inertia ($\leq \phi 8$) [kg·cm ²]	Moment of inertia ($\leq \phi 14$) [kg·cm ²]	Moment of inertia ($\leq \phi 19$) [kg·cm ²]
			Maximum radial load [N]	Maximum axial load [N]	Weight [kg]			
060B	2	3	3000	2700	2.0	0.320	0.395	0.584
		4	3000	2700		0.271	0.346	0.535
		5	3000	2700		0.251	0.326	0.516
		6	3000	2700		0.242	0.317	0.506
		7	3000	2700		0.235	0.310	0.500
		8	3000	2700		0.232	0.307	0.496
		9	3000	2700		0.229	0.304	0.494
	3	10	3000	2700	0.228	0.303	0.492	
		15	3000	2700	1.8	0.074	0.118	–
		16	3000	2700		0.079	0.124	–
		20	3000	2700		0.072	0.116	–
		25	3000	2700		0.071	0.115	–
		28	3000	2700		0.077	0.122	–
		30	3000	2700		0.062	0.106	–
		35	3000	2700		0.070	0.115	–
		40	3000	2700		0.061	0.106	–
		45	3000	2700		0.070	0.115	–
		50	3000	2700		0.061	0.106	–
		60	3000	2700		0.061	0.106	–
		70	3000	2700		0.061	0.106	–
80	3000	2700	0.061	0.105		–		
90	3000	2700	0.061	0.105	–			
100	3000	2700	0.061	0.105	–			

- ※ 1 With nominal input speed, service life is 20,000 hours.
- ※ 2 The maximum torque when starting and stopping.
- ※ 3 The maximum torque when it receives shock (up to 1,000 times)
- ※ 4 The maximum average input speed.
- ※ 5 The maximum momentary input speed.
- ※ 6 With this load and nominal input speed, service life will be 20,000 hours.
(Applied to the output shaft center, at axial load 0)
- ※ 7 With this load and nominal input speed, service life will be 20,000 hours.
(Applied to the output side bearing, at radial load 0)
- ※ 8 The maximum radial load the reducer can accept.
- ※ 9 The maximum axial load the reducer can accept.
- ※ 10 The weight may vary slightly model to model

EVS-075B

Frame size	Stage	Ratio	※1	※2	※3	※4	※5	※6	※7
			Nominal output torque [Nm]	Maximum output torque [Nm]	Emergency stop torque [Nm]	Nominal input speed [rpm]	Maximum input speed [rpm]	Permitted radial load [N]	Permitted axial load [N]
075B	2	3	45	65	130	3000	6000	2300	3400
		4	60	90	170	3000	6000	2500	3700
		5	65	90	220	3000	6000	2700	3900
		6	65	90	220	3000	6000	2800	3900
		7	65	90	220	3000	6000	3000	3900
		8	65	90	220	3000	6000	3100	3900
		9	45	65	170	3000	6000	3200	3900
	3	10	45	65	170	3000	6000	3300	3900
		15	45	65	170	3000	6000	3700	3900
		16	65	110	220	3000	6000	3800	3900
		20	65	110	220	3000	6000	4000	3900
		25	65	110	220	3000	6000	4300	3900
		28	65	110	220	3000	6000	4300	3900
		30	45	65	170	3000	6000	4300	3900
		35	65	110	220	3000	6000	4300	3900
		40	65	110	220	3000	6000	4300	3900
		45	45	65	170	3000	6000	4300	3900
		50	65	110	220	3000	6000	4300	3900
		60	65	110	220	3000	6000	4300	3900
		70	65	110	220	3000	6000	4300	3900
80	65	110	220	3000	6000	4300	3900		
90	45	65	170	3000	6000	4300	3900		
100	45	65	170	3000	6000	4300	3900		

Frame size	Stage	Ratio	※8	※9	Weight [kg]	※10	Moment of inertia (≤ φ 8) [kg·cm ²]	Moment of inertia (≤ φ 14) [kg·cm ²]	Moment of inertia (≤ φ 19) [kg·cm ²]	Moment of inertia (≤ φ 28) [kg·cm ²]
			Maximum radial load [N]	Maximum axial load [N]						
075B	2	3	4300	3900	4.8	-	2.07	2.40	4.53	
		4	4300	3900		-	1.87	2.20	4.32	
		5	4300	3900		-	1.78	2.11	4.24	
		6	4300	3900		-	1.74	2.07	4.20	
		7	4300	3900		-	1.72	2.05	4.17	
		8	4300	3900		-	1.70	2.03	4.16	
		9	4300	3900		-	1.69	2.02	4.15	
	3	10	4300	3900	-	1.69	2.02	4.15		
		15	4300	3900	4.1	0.33	0.41	0.60	-	
		16	4300	3900		0.38	0.46	0.65	-	
		20	4300	3900		0.33	0.40	0.59	-	
		25	4300	3900		0.32	0.40	0.59	-	
		28	4300	3900		0.37	0.45	0.64	-	
		30	4300	3900		0.25	0.32	0.51	-	
		35	4300	3900		0.32	0.40	0.58	-	
		40	4300	3900		0.25	0.32	0.51	-	
		45	4300	3900		0.32	0.39	0.58	-	
		50	4300	3900		0.25	0.32	0.51	-	
		60	4300	3900		0.25	0.32	0.51	-	
		70	4300	3900		0.25	0.32	0.51	-	
80	4300	3900	0.25	0.32		0.51	-			
90	4300	3900	0.25	0.32	0.51	-				
100	4300	3900	0.25	0.32	0.51	-				

- ※ 1 With nominal input speed, service life is 20,000 hours.
- ※ 2 The maximum torque when starting and stopping.
- ※ 3 The maximum torque when it receives shock (up to 1,000 times)
- ※ 4 The maximum average input speed.
- ※ 5 The maximum momentary input speed.
- ※ 6 With this load and nominal input speed, service life will be 20,000 hours.
(Applied to the output shaft center, at axial load 0)
- ※ 7 With this load and nominal input speed, service life will be 20,000 hours.
(Applied to the output side bearing, at radial load 0)
- ※ 8 The maximum radial load the reducer can accept.
- ※ 9 The maximum axial load the reducer can accept.
- ※ 10 The weight may vary slightly model to model.

EVS-100B

Frame size	Stage	Ratio	※1	※2	※3	※4	※5	※6	※7
			Nominal output torque [Nm]	Maximum output torque [Nm]	Emergency stop torque [Nm]	Nominal input speed [rpm]	Maximum input speed [rpm]	Permitted radial load [N]	Permitted axial load [N]
100B	2	3	75	150	320	3000	6000	3400	4800
		4	100	200	430	3000	6000	3700	5200
		5	120	240	500	3000	6000	4000	5600
		6	150	300	550	3000	6000	4200	5900
		7	150	300	550	3000	6000	4400	6100
		8	150	300	550	3000	6000	4600	6300
		9	110	200	450	3000	6000	4800	6300
	3	10	110	200	450	3000	6000	4900	6300
		15	110	200	450	3000	6000	5600	6300
		16	130	260	550	3000	6000	5700	6300
		20	150	300	550	3000	6000	6100	6300
		25	150	300	550	3000	6000	6500	6300
		28	150	300	550	3000	6000	6700	6300
		30	110	200	450	3000	6000	6900	6300
		35	150	300	550	3000	6000	7000	6300
		40	150	300	550	3000	6000	7000	6300
		45	110	200	450	3000	6000	7000	6300
		50	150	300	550	3000	6000	7000	6300
		60	150	300	550	3000	6000	7000	6300
		70	150	300	550	3000	6000	7000	6300
80	150	300	550	3000	6000	7000	6300		
90	110	200	450	3000	6000	7000	6300		
100	110	200	450	3000	6000	7000	6300		

※8

※9

※10

Frame size	Stage	Ratio	Maximum radial load	Maximum axial load	Weight	Moment of inertia ($\leq \phi 14$)	Moment of inertia ($\leq \phi 19$)	Moment of inertia ($\leq \phi 28$)	Moment of inertia ($\leq \phi 38$)
			[N]	[N]	[kg]	[kg·cm ²]	[kg·cm ²]	[kg·cm ²]	[kg·cm ²]
100B	2	3	7000	6300	10.5	-	6.61	8.21	15.28
		4	7000	6300		-	5.41	7.01	14.08
		5	7000	6300		-	4.97	6.57	13.64
		6	7000	6300		-	4.73	6.33	13.40
		7	7000	6300		-	4.62	6.22	13.29
		8	7000	6300		-	4.53	6.12	13.20
		9	7000	6300		-	4.47	6.07	13.14
	3	10	7000	6300	-	4.45	6.04	13.11	
		15	7000	6300	10.1	2.24	2.57	4.70	-
		16	7000	6300		2.45	2.78	4.91	-
		20	7000	6300		2.19	2.52	4.65	-
		25	7000	6300		2.18	2.51	4.63	-
		28	7000	6300		2.40	2.73	4.86	-
		30	7000	6300		1.87	2.20	4.33	-
		35	7000	6300		2.16	2.49	4.62	-
		40	7000	6300		1.86	2.19	4.32	-
		45	7000	6300		2.15	2.48	4.61	-
		50	7000	6300		1.86	2.19	4.31	-
		60	7000	6300		1.85	2.18	4.31	-
		70	7000	6300		1.85	2.18	4.31	-
80	7000	6300	1.85	2.18		4.31	-		
90	7000	6300	1.85	2.18	4.31	-			
100	7000	6300	1.85	2.18	4.31	-			

※ 1 With nominal input speed, service life is 20,000 hours.

※ 2 The maximum torque when starting and stopping.

※ 3 The maximum torque when it receives shock (up to 1,000 times)

※ 4 The maximum average input speed.

※ 5 The maximum momentary input speed.

※ 6 With this load and nominal input speed, service life will be 20,000 hours.

(Applied to the output shaft center, at axial load 0)

※ 7 With this load and nominal input speed, service life will be 20,000 hours.

(Applied to the output side bearing, at radial load 0)

※ 8 The maximum radial load the reducer can accept.

※ 9 The maximum axial load the reducer can accept.

※ 10 The weight may vary slightly model to model.

EVS-140B

Frame size	Stage	Ratio	※1	※2	※3	※4	※5	※6	※7
			Nominal output torque [Nm]	Maximum output torque [Nm]	Emergency stop torque [Nm]	Nominal input speed [rpm]	Maximum input speed [rpm]	Permitted radial load [N]	Permitted axial load [N]
140B	2	3	130	260	700	2000	4000	6700	9000
		4	170	340	950	2000	4000	7400	9000
		5	200	400	1100	2000	4000	7900	9000
		6	260	520	1100	2000	4000	8300	9000
		7	300	600	1100	2000	4000	8700	9000
		8	300	600	1100	2000	4000	9100	9000
		9	200	400	750	2000	4000	9400	9000
	3	10	200	400	750	2000	4000	9700	9000
		15	200	400	750	2000	4000	10000	9000
		16	300	600	1100	2000	4000	10000	9000
		20	300	600	1100	2000	4000	10000	9000
		25	300	600	1100	2000	4000	10000	9000
		28	300	600	1100	2000	4000	10000	9000
		30	200	400	750	2000	4000	10000	9000
		35	300	600	1100	2000	4000	10000	9000
		40	300	600	1100	2000	4000	10000	9000
		45	200	400	750	2000	4000	10000	9000
		50	300	600	1100	2000	4000	10000	9000
		60	300	600	1100	2000	4000	10000	9000
		70	300	600	1100	2000	4000	10000	9000
80	300	600	1100	2000	4000	10000	9000		
90	200	400	750	2000	4000	10000	9000		
100	200	400	750	2000	4000	10000	9000		

Frame size	Stage	Ratio	※8	※9	Weight [kg]	※10	※10	※10	※10
			Maximum radial load [N]	Maximum axial load [N]		Moment of inertia (≤ φ 19) [kg·cm ²]	Moment of inertia (≤ φ 28) [kg·cm ²]	Moment of inertia (≤ φ 38) [kg·cm ²]	Moment of inertia (≤ φ 48) [kg·cm ²]
140B	2	3	10000	9000	20.6	-	23.01	27.38	40.61
		4	10000	9000		-	18.49	22.86	36.09
		5	10000	9000		-	16.85	21.22	34.45
		6	10000	9000		-	15.97	20.34	33.57
		7	10000	9000		-	15.55	19.92	33.15
		8	10000	9000		-	15.21	19.58	32.81
		9	10000	9000		-	14.75	19.12	32.35
	3	10	10000	9000	-	14.64	19.02	32.25	
		15	10000	9000	20.7	6.40	7.99	15.06	-
		16	10000	9000		7.29	8.88	15.95	-
		20	10000	9000		6.22	7.81	14.88	-
		25	10000	9000		6.15	7.75	14.82	-
		28	10000	9000		7.09	8.68	15.75	-
		30	10000	9000		4.99	6.58	13.66	-
		35	10000	9000		6.09	7.68	14.76	-
		40	10000	9000		4.94	6.54	13.61	-
		45	10000	9000		6.07	7.66	14.73	-
		50	10000	9000		4.93	6.52	13.59	-
		60	10000	9000		4.92	6.51	13.59	-
		70	10000	9000		4.91	6.51	13.58	-
80	10000	9000	4.91	6.50		13.58	-		
90	10000	9000	4.91	6.50	13.57	-			
100	10000	9000	4.91	6.50	13.57	-			

- ※ 1 With nominal input speed, service life is 20,000 hours.
- ※ 2 The maximum torque when starting and stopping.
- ※ 3 The maximum torque when it receives shock (up to 1,000 times)
- ※ 4 The maximum average input speed.
- ※ 5 The maximum momentary input speed.
- ※ 6 With this load and nominal input speed, service life will be 20,000 hours.
(Applied to the output shaft center, at axial load 0)
- ※ 7 With this load and nominal input speed, service life will be 20,000 hours.
(Applied to the output side bearing, at radial load 0)
- ※ 8 The maximum radial load the reducer can accept.
- ※ 9 The maximum axial load the reducer can accept.
- ※ 10 The weight may vary slightly model to model.

EVS-060B 2stage

Input shaft bore $\leq \phi 8$

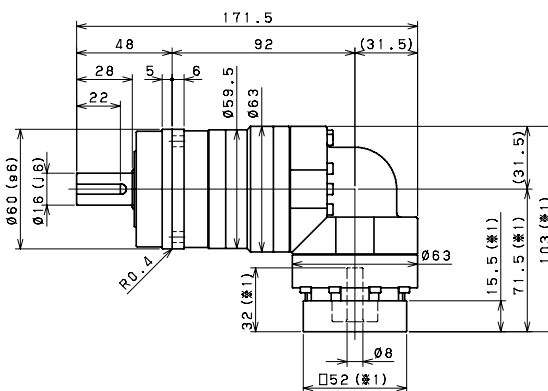
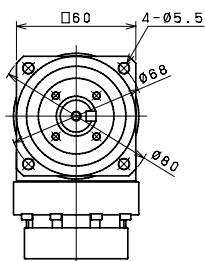

Input shaft bore $\leq \phi 14$

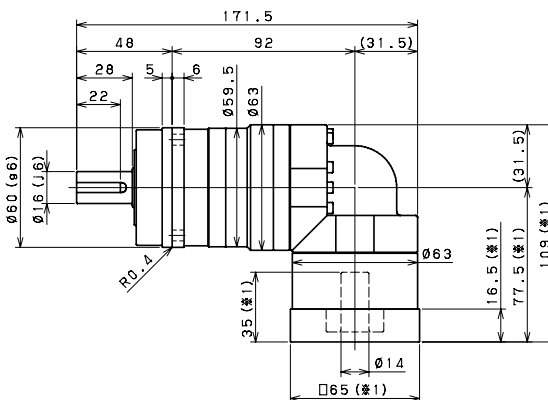
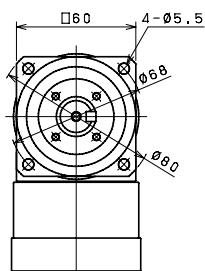

Input shaft bore $\leq \phi 8$

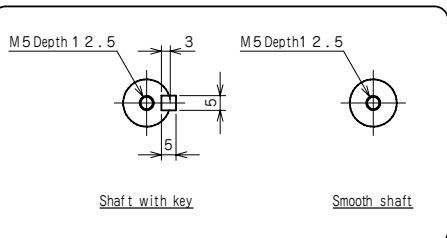
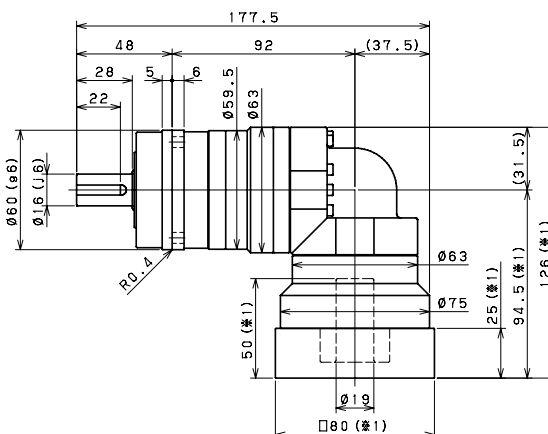
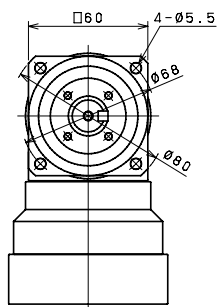

- ※ 1 Length will vary depending on motor.
- ※ 2 Bushing will be inserted to adapt to motor shaft

EVS-060B 3stage

Input shaft bore $\leq \phi 8$

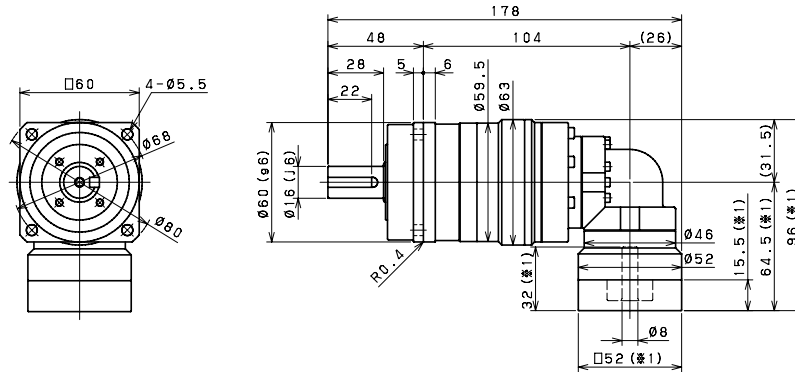

Input shaft bore $\leq \phi 14$

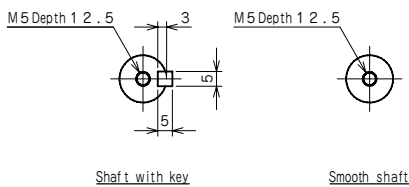
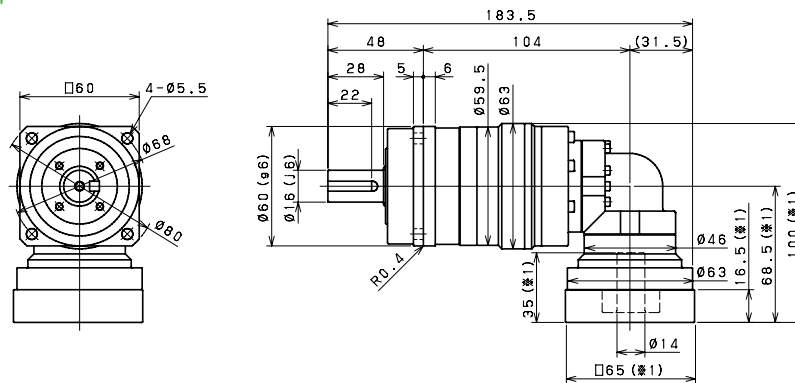

- ※ 1 Length will vary depending on motor.
- ※ 2 Bushing will be inserted to adapt to motor shaft.

EVS-075B 2stage

Input shaft bore $\leq \phi 14$

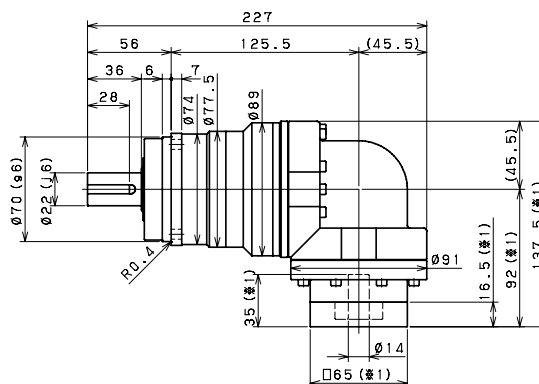
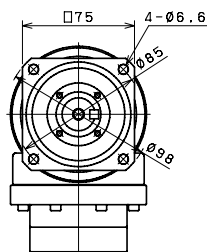

Input shaft bore $\leq \phi 19$

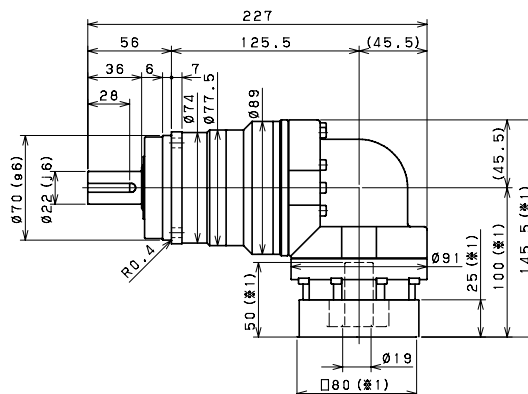
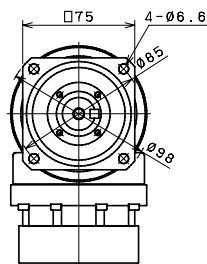

Input shaft bore $\leq \phi 28$

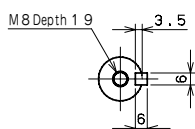
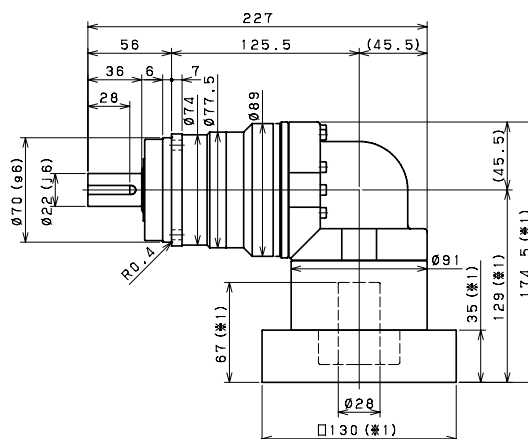
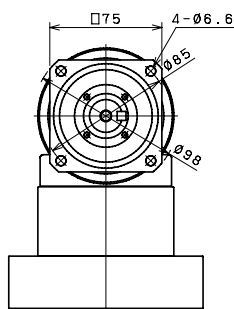

Shaft with key

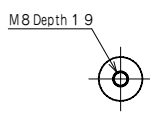

Smooth shaft

- ※ 1 Length will vary depending on motor.
- ※ 2 Bushing will be inserted to adapt to motor shaft.

EVS-075B 3stage

Input shaft bore $\leq \phi 8$

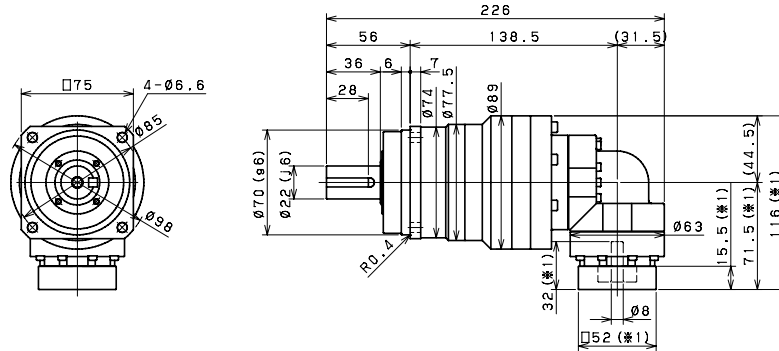

Input shaft bore $\leq \phi 14$

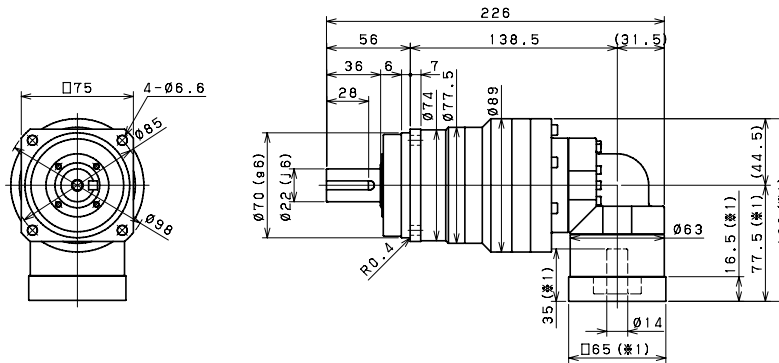

Input shaft bore $\leq \phi 19$

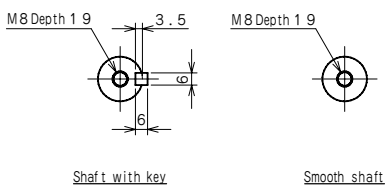
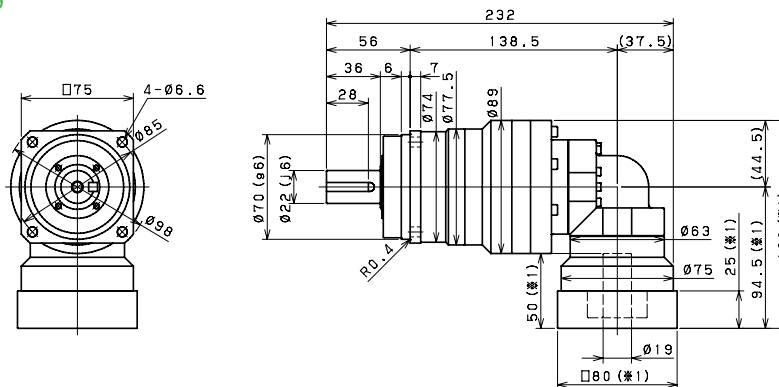

- ※1 Length will vary depending on motor.
- ※2 Bushing will be inserted to adapt to motor shaft.

EVS-100B 2stage

Input shaft bore $\leq \phi 19$

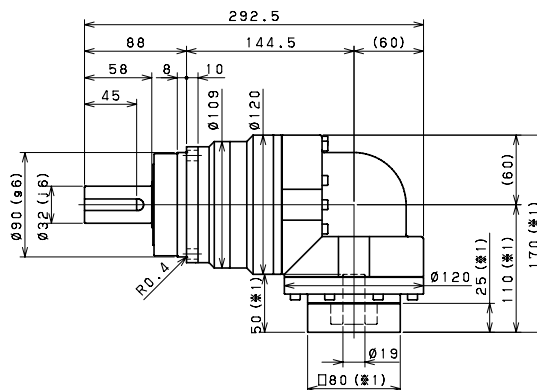
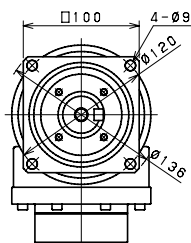

Input shaft bore $\leq \phi 28$

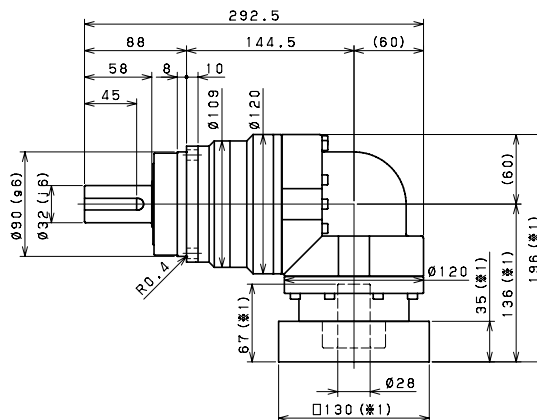
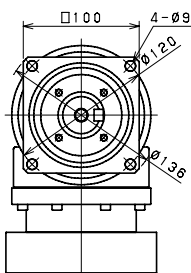

Input shaft bore $\leq \phi 38$

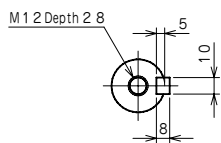
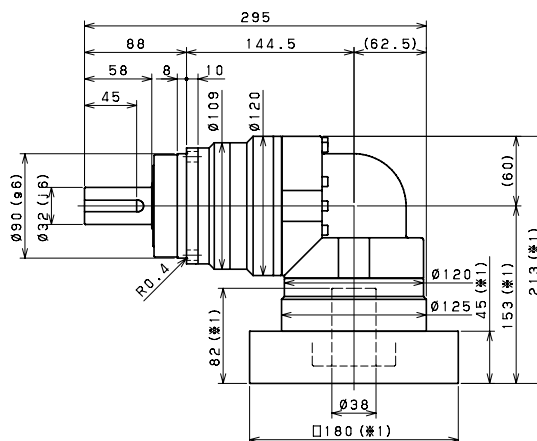
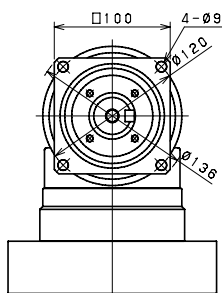

Shaft with key

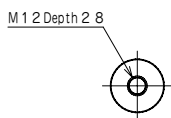

Smooth shaft

※ 1 Length will vary depending on motor.

※ 2 Bushing will be inserted to adapt to motor shaft.

EVS-100B 3stage

Input shaft bore $\leq \phi 14$

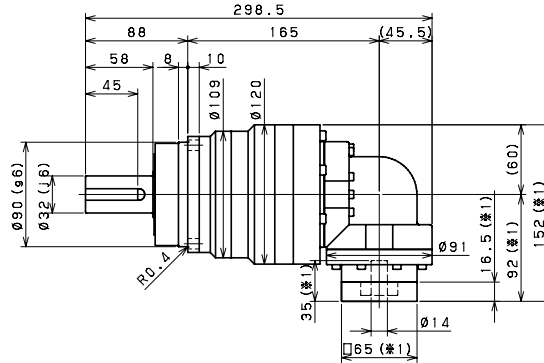
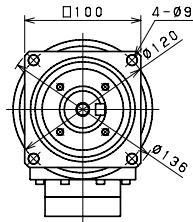

Input shaft bore $\leq \phi 19$

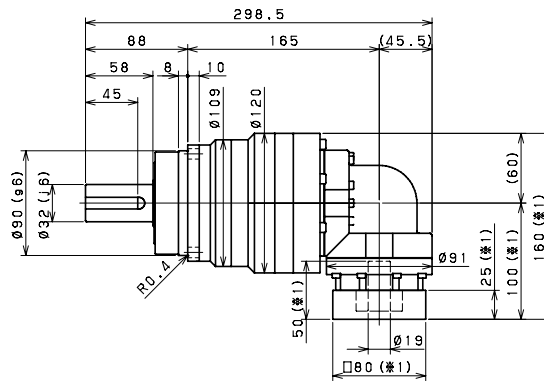
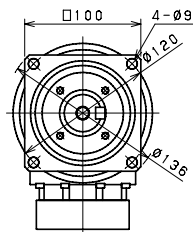

Input shaft bore $\leq \phi 28$

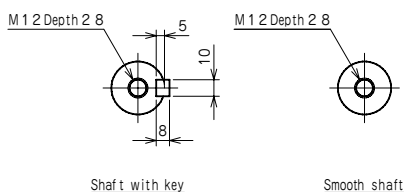
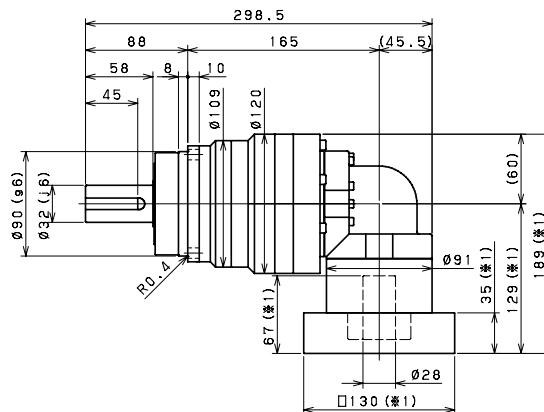
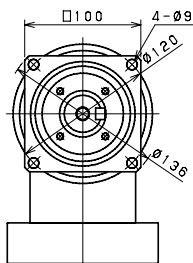

- *1 Length will vary depending on motor.
- *2 Bushing will be inserted to adapt to motor shaft.

EVS-140B 2stage

Input shaft bore $\leq \phi 28$

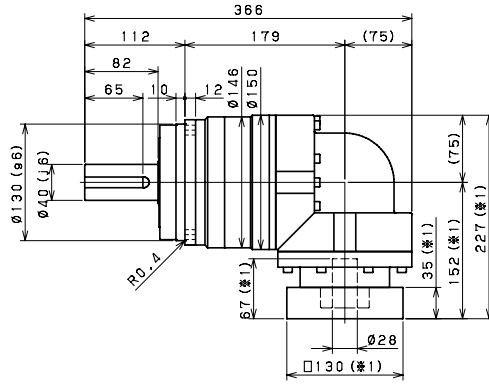
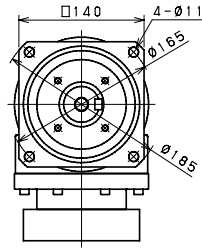

Input shaft bore $\leq \phi 38$

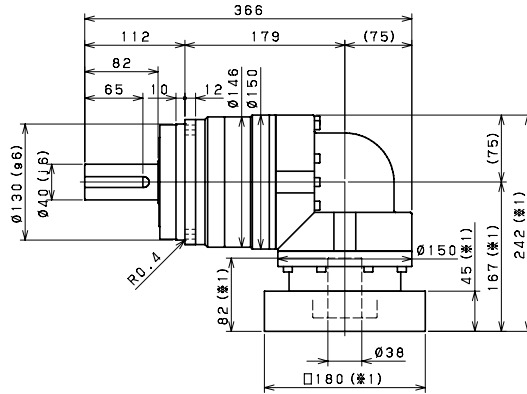
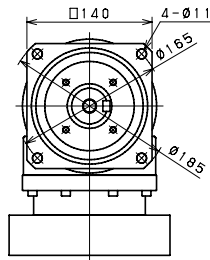

Input shaft bore $\leq \phi 48$

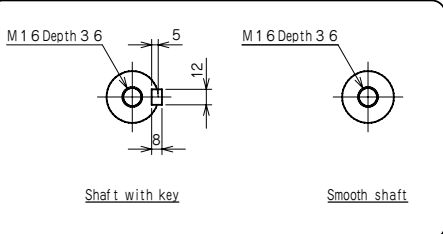
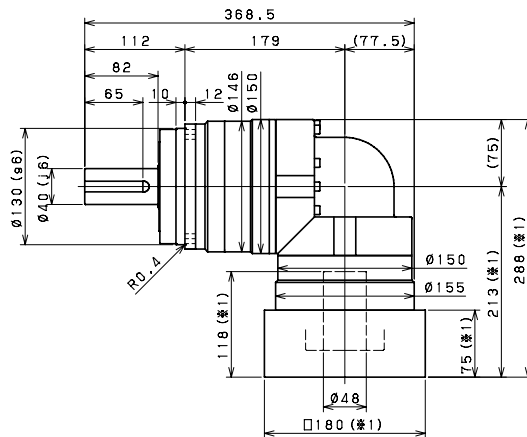
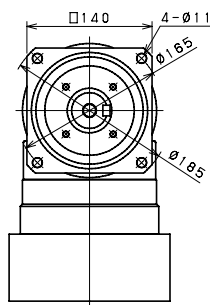

- ※ 1 Length will vary depending on motor.
- ※ 2 Bushing will be inserted to adapt to motor shaft.

EVS-140B 3stage

Input shaft bore $\leq \phi 19$

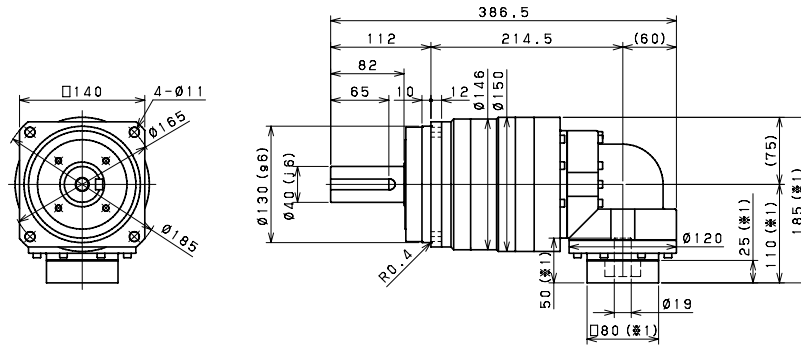

Input shaft bore $\leq \phi 28$

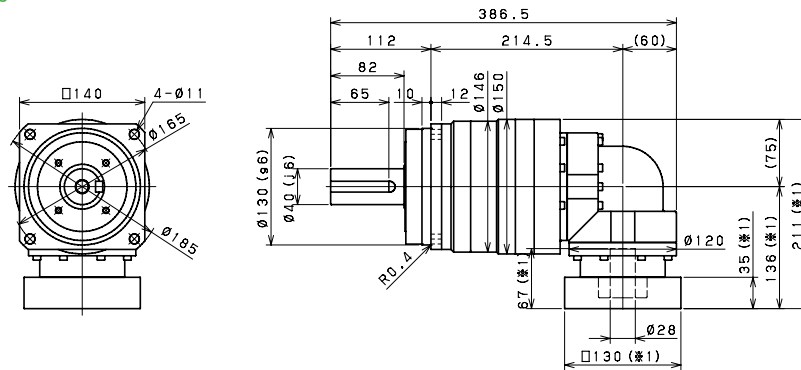

Input shaft bore $\leq \phi 38$

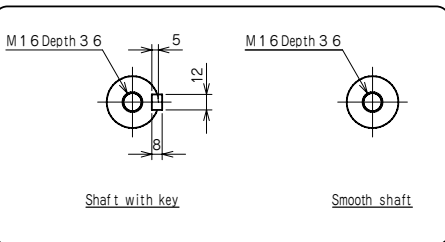
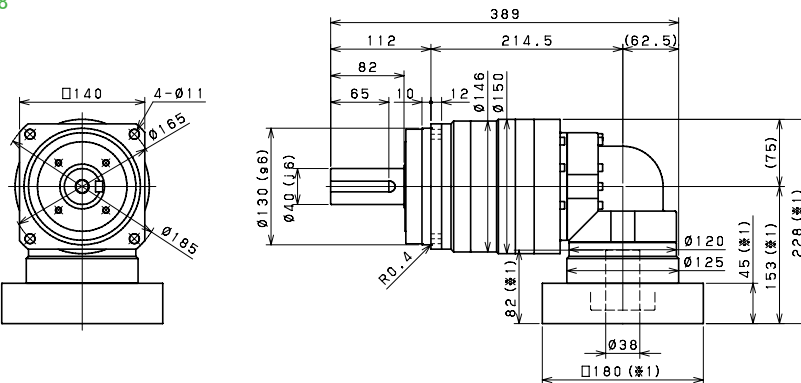

- ※ 1 Length will vary depending on motor.
- ※ 2 Bushing will be inserted to adapt to motor shaft.

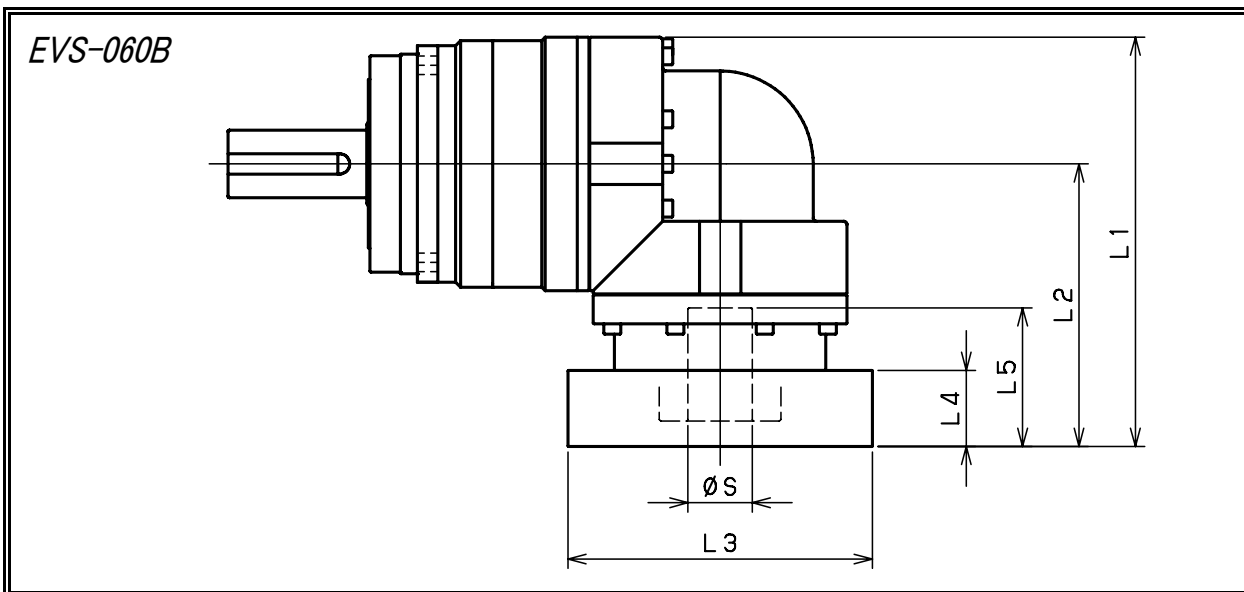

Model number	**: Adapter code	Single					Double				
		L1	L2	L3	L4	L5	L1	L2	L3	L4	L5
EVS-060B-□-□-8** (S ≤ 8)	AA·AC·AD·AF·AG	103	71.5	□52	15.5	32	96	64.5	□52	15.5	32
	AB·AE·AH·AJ·AK	108	76.5	□52	20.5	37	101	69.5	□52	20.5	37
	BA·BB·BD·BE	103	71.5	□60	15.5	32	96	64.5	□60	15.5	32
	BC·BF	108	76.5	□60	20.5	37	101	69.5	□60	20.5	37
	CA	108	76.5	□70	20.5	37	101	69.5	□70	20.5	37
EVS-060B-□-□-14** (8 < S ≤ 14)	BA·BB·BD·BE·BF·BG·BJ·BK	109	77.5	□65	16.5	35	100	68.5	□65	16.5	35
	BC·BH	114	82.5	□65	21.5	40	105	73.5	□65	21.5	40
	BL	119	87.5	□65	26.5	45	110	78.5	□65	26.5	45
	CA	109	77.5	□70	16.5	35	100	68.5	□70	16.5	35
	CB	114	82.5	□70	21.5	40	105	73.5	□70	21.5	40
	DA·DB·DC·DD·DF·DH	109	77.5	□80	16.5	35	100	68.5	□80	16.5	35
	DE	114	82.5	□80	21.5	40	105	73.5	□80	21.5	40
	DG	119	87.5	□80	26.5	45	110	78.5	□80	26.5	45
	EA·EB·EC	109	77.5	□90	16.5	35	100	68.5	□90	16.5	35
	ED	119	87.5	□90	26.5	45	110	78.5	□90	26.5	45
	FA	109	77.5	□100	16.5	35	100	68.5	□100	16.5	35
	GA	109	77.5	□115	16.5	35	100	68.5	□115	16.5	35
EVS-060B-□-□-19** (14 < S ≤ 19)	DA·DB·DC	126	94.5	□80	25	50					
	DD	136	104.5	□80	35	60					
	DE	131	99.5	□80	30	55					
	EA	131	99.5	□90	30	55					
	EB	126	94.5	□90	25	50					
	EC	136	104.5	□90	35	60					
	FA	126	94.5	□100	25	50					
	FB	136	104.5	□100	35	60					
	GA·GC	131	99.5	□115	30	55					
	GB·GD	126	94.5	□115	25	50					
	HA	126	94.5	□130	25	50					
	HB	141	109.5	□130	40	65					
HC·HD·HE	131	99.5	□130	30	55						

※ 1 Single reduction : 1/3 ~ 1/10, Double reduction : 1/15 ~ 1/100

※ 2 Bushing will be inserted to adapt to motor shaft.

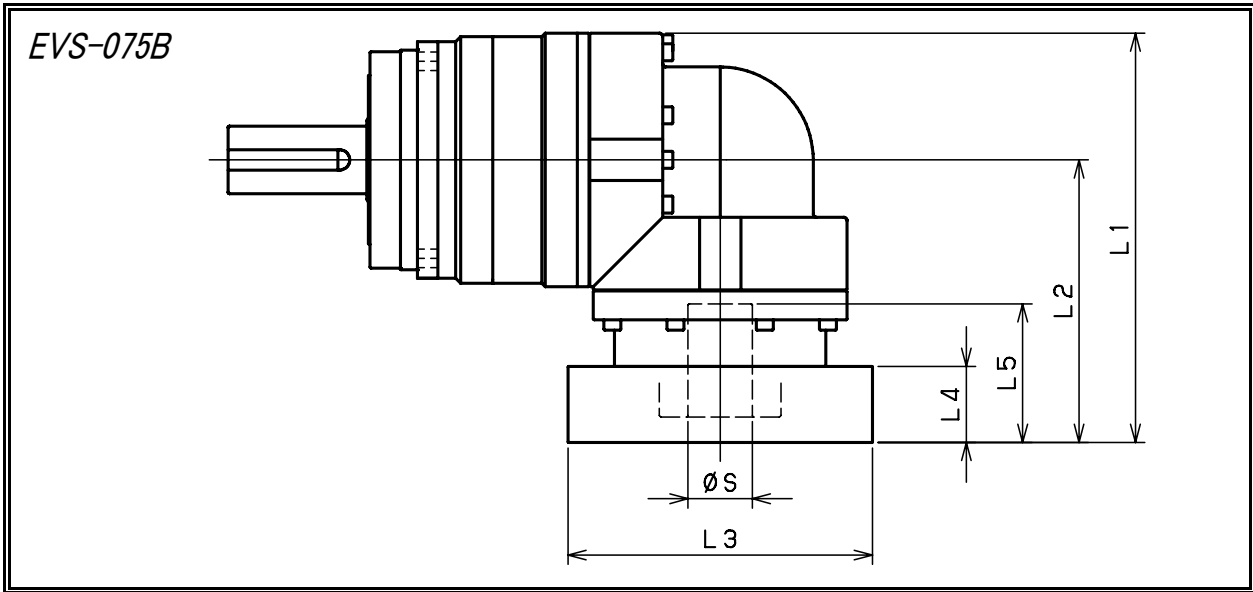

Model number	** : Adapter code	Single					Double				
		L1	L2	L3	L4	L5	L1	L2	L3	L4	L5
EVS-075B-□-□-8** (S ≤ 8)	AA·AC·AD·AF·AG	/	/	/	/	/	116	71.5	□52	15.5	32
	AB·AE·AH·AJ·AK	/	/	/	/	/	121	76.5	□52	20.5	37
	BA·BB·BD·BE	/	/	/	/	/	116	71.5	□60	15.5	32
	BC·BF	/	/	/	/	/	121	76.5	□60	20.5	37
	CA	/	/	/	/	/	121	76.5	□70	20.5	37
EVS-075B-□-□-14** (8 < S ≤ 14)	BA·BB·BD·BE·BF·BG·BJ·BK	137.5	92	□65	16.5	35	122	77.5	□65	16.5	35
	BC·BH	142.5	97	□65	21.5	40	127	82.5	□65	21.5	40
	BL	147.5	102	□65	26.5	45	132	87.5	□65	26.5	45
	CA	137.5	92	□70	16.5	35	122	77.5	□70	16.5	35
	CB	142.5	97	□70	21.5	40	127	82.5	□70	21.5	40
	DA·DB·DC·DD·DF·DH	137.5	92	□80	16.5	35	122	77.5	□80	16.5	35
	DE	142.5	97	□80	21.5	40	127	82.5	□80	21.5	40
	DG	147.5	102	□80	26.5	45	132	87.5	□80	26.5	45
	EA·EB·EC	137.5	92	□90	16.5	35	122	77.5	□90	16.5	35
	ED	147.5	102	□90	26.5	45	132	87.5	□90	26.5	45
	FA	137.5	92	□100	16.5	35	122	77.5	□100	16.5	35
GA	137.5	92	□115	16.5	35	122	77.5	□115	16.5	35	
EVS-075B-□-□-19** (14 < S ≤ 19)	DA·DB·DC	145.5	100	□80	25	50	139	94.5	□80	25	50
	DD	155.5	110	□80	35	60	149	104.5	□80	35	60
	DE	150.5	105	□80	30	55	144	99.5	□80	30	55
	EA	150.5	105	□90	30	55	144	99.5	□90	30	55
	EB	145.5	100	□90	25	50	139	94.5	□90	25	50
	EC	155.5	110	□90	35	60	149	104.5	□90	35	60
	FA	145.5	100	□100	25	50	139	94.5	□100	25	50
	FB	155.5	110	□100	35	60	149	104.5	□100	35	60
	GA·GC	150.5	105	□115	30	55	144	99.5	□115	30	55
	GB·GD	145.5	100	□115	25	50	139	94.5	□115	25	50
	HA	145.5	100	□130	25	50	139	94.5	□130	25	50
	HB	160.5	115	□130	40	65	154	109.5	□130	40	65
	HC·HD·HE	150.5	105	□130	30	55	144	99.5	□130	30	55
EVS-075B-□-□-28** (19 < S ≤ 28)	FA·FB·FC	174.5	129	□100	35	67	/	/	/	/	/
	GA·GB·GC·GD·GE·GF·GG	174.5	129	□115	35	67	/	/	/	/	/
	HA·HC·HD	174.5	129	□130	35	67	/	/	/	/	/
	HB	184.5	139	□130	45	77	/	/	/	/	/
	JA·JB·JC	174.5	129	□150	35	67	/	/	/	/	/
	KA·KB	174.5	129	□180	35	67	/	/	/	/	/
	LA	174.5	129	□200	35	67	/	/	/	/	/
MA	174.5	129	□220	35	67	/	/	/	/	/	

※ 1 Single reduction : 1/3 ~ 1/10, Double reduction : 1/15 ~ 1/100

※ 2 Bushing will be inserted to adapt to motor shaft.

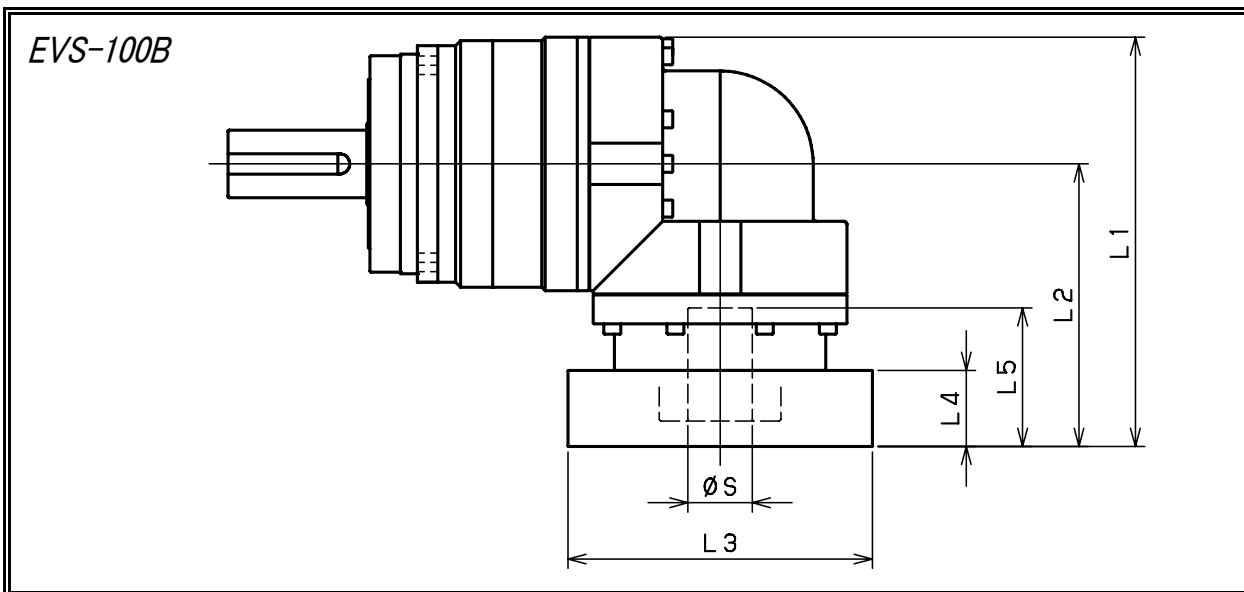

Model number	** : Adapter code	Single					Double				
		L1	L2	L3	L4	L5	L1	L2	L3	L4	L5
EVS-100B-□-□-14** (S ≤ 14)	BA·BB·BD·BE·BF·BG·BJ·BK	/	/	/	/	/	152	92	□65	16.5	35
	BC·BH	/	/	/	/	/	157	97	□65	21.5	40
	BL	/	/	/	/	/	162	102	□65	26.5	45
	CA	/	/	/	/	/	152	92	□70	16.5	35
	CB	/	/	/	/	/	157	97	□70	21.5	40
	DA·DB·DC·DD·DF·DH	/	/	/	/	/	152	92	□80	16.5	35
	DE	/	/	/	/	/	157	97	□80	21.5	40
	DG	/	/	/	/	/	162	102	□80	26.5	45
	EA·EB·EC	/	/	/	/	/	152	92	□90	16.5	35
	ED	/	/	/	/	/	162	102	□90	26.5	45
	FA	/	/	/	/	/	152	92	□100	16.5	35
	GA	/	/	/	/	/	152	92	□115	16.5	35
EVS-100B-□-□-19** (14 < S ≤ 19)	DA·DB·DC	170	110	□80	25	50	160	100	□80	25	50
	DD	180	120	□80	35	60	170	110	□80	35	60
	DE	175	115	□80	30	55	165	105	□80	30	55
	EA	175	115	□90	30	55	165	105	□90	30	55
	EB	170	110	□90	25	50	160	100	□90	25	50
	EC	180	120	□90	35	60	170	110	□90	35	60
	FA	170	110	□100	25	50	160	100	□100	25	50
	FB	180	120	□100	35	60	170	110	□100	35	60
	GA·GC	175	115	□115	30	55	165	105	□115	30	55
	GB·GD	170	110	□115	25	50	160	100	□115	25	50
	HA	170	110	□130	25	50	160	100	□130	25	50
	HB	185	125	□130	40	65	175	115	□130	40	65
HC·HD·HE	175	115	□130	30	55	165	105	□130	30	55	
EVS-100B-□-□-28** (19 < S ≤ 28)	FA·FB·FC	196	136	□100	35	67	189	129	□100	35	67
	GA·GB·GC·GD·GE·GF·GG	196	136	□115	35	67	189	129	□115	35	67
	HA·HC·HD	196	136	□130	35	67	189	129	□130	35	67
	HB	206	146	□130	45	77	199	139	□130	45	77
	JA·JB·JC	196	136	□150	35	67	189	129	□150	35	67
	KA·KB	196	136	□180	35	67	189	129	□180	35	67
	LA	196	136	□200	35	67	189	129	□200	35	67
	MA	196	136	□220	35	67	189	129	□220	35	67
EVS-100B-□-□-38** (28 < S ≤ 38)	HA	213	153	□130	45	82	/	/	/	/	/
	HB	208	148	□130	40	77	/	/	/	/	/
	JA	213	153	□150	45	82	/	/	/	/	/
	KA·KB·KC	213	153	□180	45	82	/	/	/	/	/
	LA	213	153	□200	45	82	/	/	/	/	/
	LB	223	163	□200	55	92	/	/	/	/	/
	MA·MB	213	153	□220	45	82	/	/	/	/	/
NA	213	153	□250	45	82	/	/	/	/	/	

※1 Single reduction : 1/3 ~ 1/10, Double reduction : 1/15 ~ 1/100

※2 Bushing will be inserted to adapt to motor shaft.

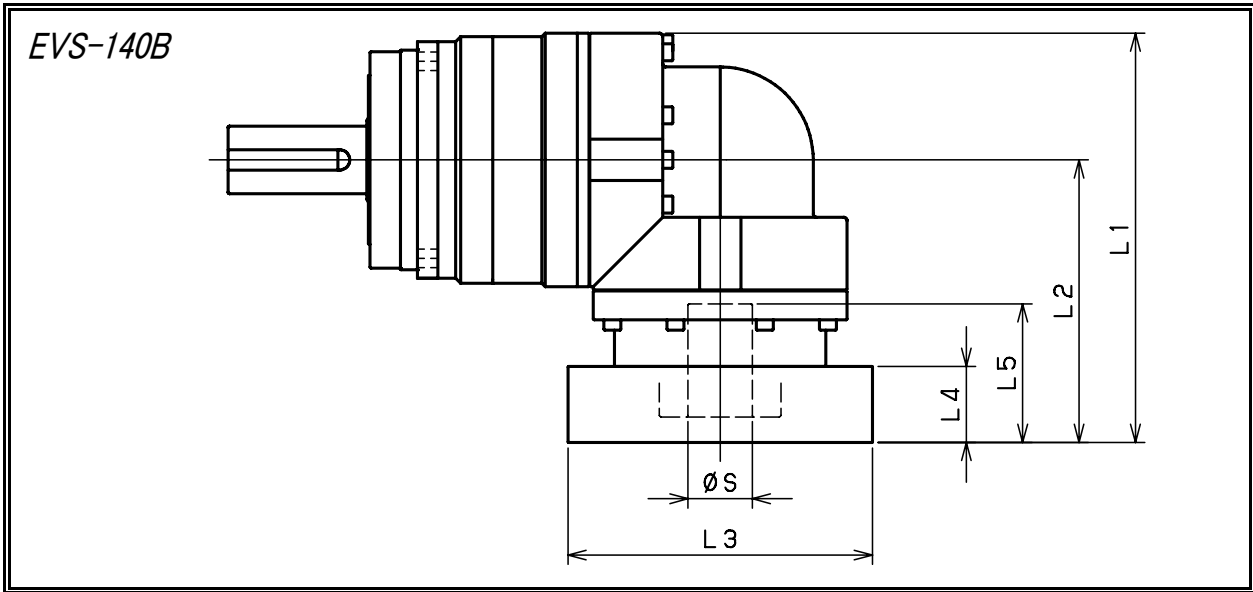

Model number	**: Adapter code	Single					Double				
		L1	L2	L3	L4	L5	L1	L2	L3	L4	L5
EVS-140B-□-□-19** ($S \leq 19$)	DA·DB·DC	/	/	/	/	/	185	110	□80	25	50
	DD	/	/	/	/	/	195	120	□80	35	60
	DE	/	/	/	/	/	190	115	□80	30	55
	EA	/	/	/	/	/	190	115	□90	30	55
	EB	/	/	/	/	/	185	110	□90	25	50
	EC	/	/	/	/	/	195	120	□90	35	60
	FA	/	/	/	/	/	185	110	□100	25	50
	FB	/	/	/	/	/	195	120	□100	35	60
	GA·GC	/	/	/	/	/	190	115	□115	30	55
	GB·GD	/	/	/	/	/	185	110	□115	25	50
	HA	/	/	/	/	/	185	110	□130	25	50
	HB	/	/	/	/	/	200	125	□130	40	65
	HC·HD·HE	/	/	/	/	/	190	115	□130	30	55
EVS-140B-□-□-28** ($19 < S \leq 28$)	FA·FB·FC	227	152	□100	35	67	211	136	□100	35	67
	GA·GB·GC·GD·GE·GF·GG	227	152	□115	35	67	211	136	□115	35	67
	HA·HC·HD	227	152	□130	35	67	211	136	□130	35	67
	HB	237	162	□130	45	77	221	146	□130	45	77
	JA·JB·JC	227	152	□150	35	67	211	136	□150	35	67
	KA·KB	227	152	□180	35	67	211	136	□180	35	67
	LA	227	152	□200	35	67	211	136	□200	35	67
MA	227	152	□220	35	67	211	136	□220	35	67	
EVS-140B-□-□-38** ($28 < S \leq 38$)	HA	242	167	□130	45	82	228	153	□130	45	82
	HB	237	162	□130	40	77	223	148	□130	40	77
	JA	242	167	□150	45	82	228	153	□150	45	82
	KA·KB·KC	242	167	□180	45	82	228	153	□180	45	82
	LA	242	167	□200	45	82	228	153	□200	45	82
	LB	252	177	□200	55	92	238	163	□200	55	92
	MA·MB	242	167	□220	45	82	228	153	□220	45	82
NA	242	167	□250	45	82	228	153	□250	45	82	
EVS-140B-□-□-48** ($38 < S \leq 48$)	KB·KC	268	193	□180	55	98	/	/	/	/	/
	KA	288	213	□180	75	118	/	/	/	/	/
	LA	268	193	□200	55	98	/	/	/	/	/
	MA	268	193	□220	55	98	/	/	/	/	/
	MB	288	213	□220	75	118	/	/	/	/	/
	NA	288	213	□250	75	118	/	/	/	/	/
PA	288	213	□280	75	118	/	/	/	/	/	

※1 Single reduction : 1/3 ~ 1/10, Double reduction : 1/15 ~ 1/100
 ※2 Bushing will be inserted to adapt to motor shaft.

SHIMPO

For servo motor

ABLE REDUCER

EVB Series

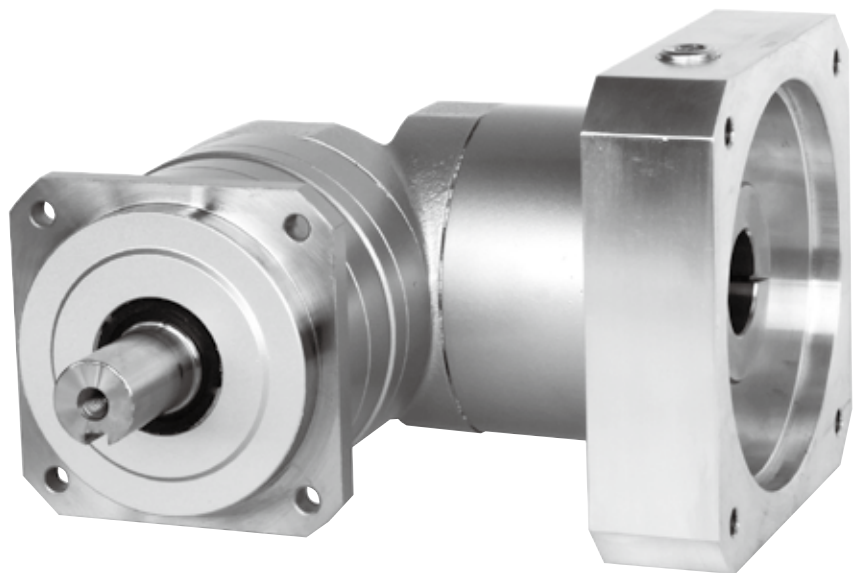

EVB series

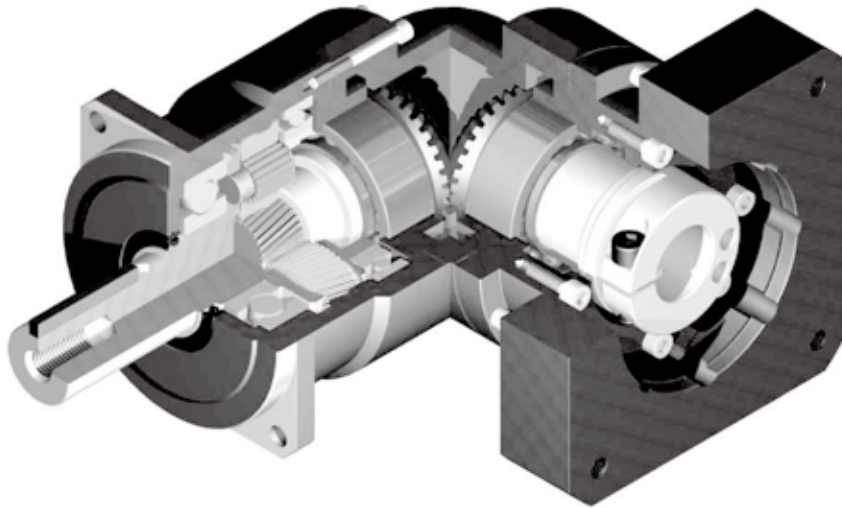

Space - saving

Right angle reducer using spiral bevel gear
Customer can locate the motor at 90 degree away from the reducer if required to save space.

High rigidity & torque

High rigidity & high torque was achieved by uncaged needle roller bearings.

Adapter-bushing connection

Can be attached to any motor all over the world.

No grease leakage

Perfect solution by high viscosity anti-separation grease.

Maintenance-free

No need to replace the grease for the life time.
Can be attached in any position.

EVB series

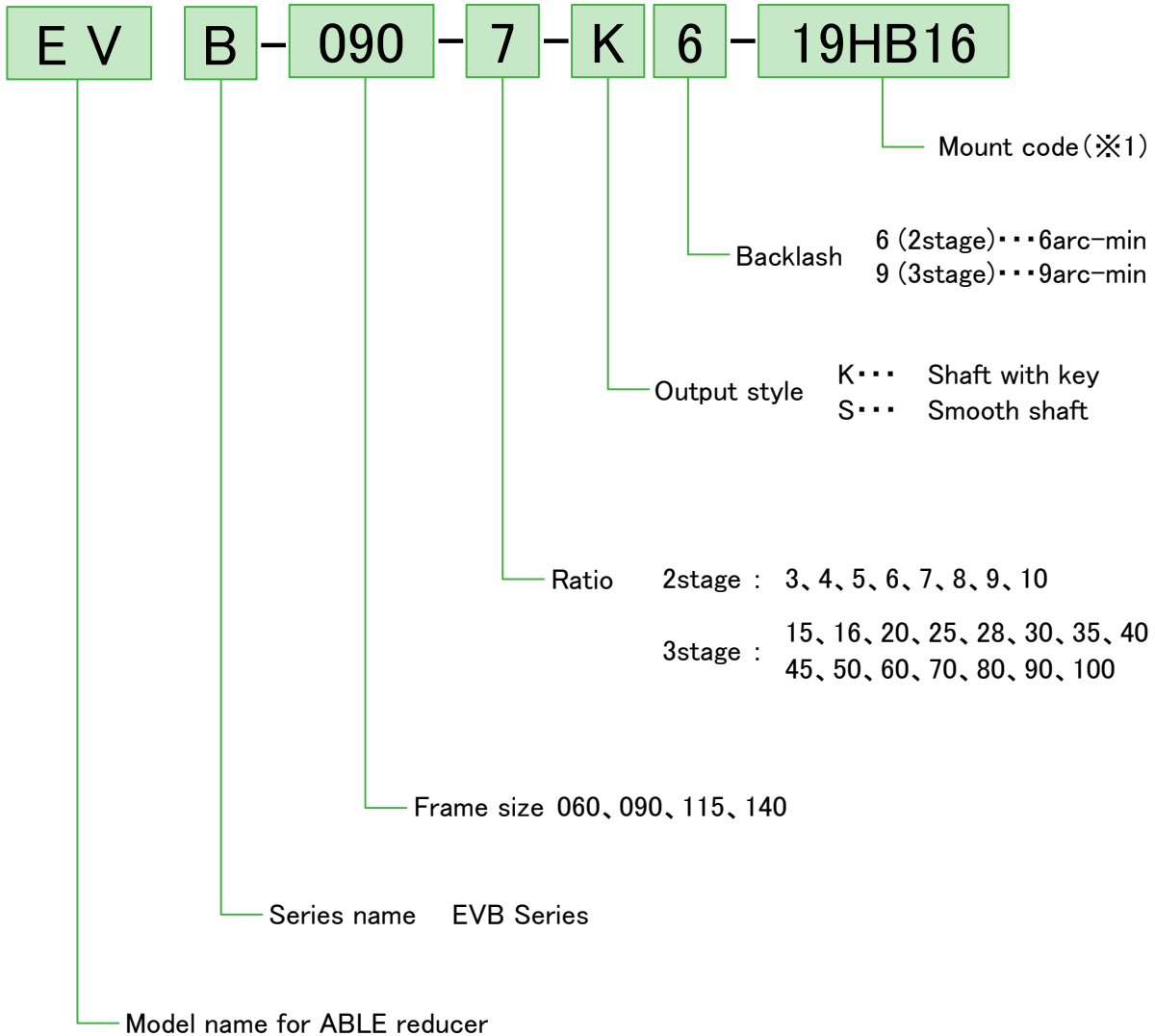

※1 Mount code

Mount code varies depending on the motor.

Please refer to reducer selection tool or contact us for more information.

Selection tool (English)

(<http://www.nidec-shimpo.co.jp/selection/eng/>)

EVB-060

Frame size	Stage	Ratio	※1	※2	※3	※4	※5	※6	※7
			Nominal output torque [Nm]	Maximum output torque [Nm]	Emergency stop torque [Nm]	Nominal input speed [rpm]	Maximum input speed [rpm]	Permitted radial load [N]	Permitted axial load [N]
060	2	3	12	24	50	3000	6000	430	310
		4	16	32	65	3000	6000	470	360
		5	22	40	80	3000	6000	510	390
		6	24	45	90	3000	6000	540	430
		7	24	45	90	3000	6000	570	460
		8	24	45	90	3000	6000	600	480
		9	16	32	65	3000	6000	620	510
	3	10	16	32	65	3000	6000	640	530
		15	16	32	65	3000	6000	740	630
		16	24	45	90	3000	6000	750	650
		20	24	45	90	3000	6000	810	720
		25	24	45	90	3000	6000	870	790
		28	24	45	90	3000	6000	910	830
		30	16	32	65	3000	6000	930	860
		35	24	45	90	3000	6000	980	920
		40	24	45	90	3000	6000	1000	970
		45	16	32	65	3000	6000	1100	1000
		50	24	45	90	3000	6000	1100	1100
		60	24	45	90	3000	6000	1200	1100
		70	24	45	90	3000	6000	1200	1100
80	24	45	90	3000	6000	1200	1100		
90	16	32	65	3000	6000	1200	1100		
100	16	32	65	3000	6000	1200	1100		

Frame size	Stage	Ratio	※8	※9	※10	Moment of inertia ($\leq \phi 8$) [kg·cm ²]	Moment of inertia ($\leq \phi 14$) [kg·cm ²]	Moment of inertia ($\leq \phi 19$) [kg·cm ²]
			Maximum radial load [N]	Maximum axial load [N]	Weight [kg]			
060	2	3	1200	1100	1.8	0.31	0.39	0.58
		4	1200	1100		0.27	0.34	0.53
		5	1200	1100		0.25	0.32	0.51
		6	1200	1100		0.24	0.31	0.50
		7	1200	1100		0.23	0.31	0.50
		8	1200	1100		0.23	0.31	0.50
		9	1200	1100		0.23	0.30	0.49
	3	10	1200	1100	0.23	0.30	0.49	
		15	1200	1100	1.6	0.073	0.118	—
		16	1200	1100		0.079	0.124	—
		20	1200	1100		0.071	0.116	—
		25	1200	1100		0.071	0.115	—
		28	1200	1100		0.077	0.122	—
		30	1200	1100		0.062	0.106	—
		35	1200	1100		0.070	0.115	—
		40	1200	1100		0.061	0.106	—
		45	1200	1100		0.070	0.115	—
		50	1200	1100		0.061	0.106	—
		60	1200	1100		0.061	0.106	—
		70	1200	1100		0.061	0.105	—
80	1200	1100	0.061	0.105		—		
90	1200	1100	0.061	0.105	—			
100	1200	1100	0.061	0.105	—			

- ※ 1 With nominal input speed, service life is 20,000 hours.
- ※ 2 The maximum torque when starting and stopping.
- ※ 3 The maximum torque when it receives shock (up to 1,000 times)
- ※ 4 The maximum average input speed.
- ※ 5 The maximum momentary input speed.
- ※ 6 With this load and nominal input speed, service life will be 20,000 hours.
(Applied to the output shaft center, at axial load 0)
- ※ 7 With this load and nominal input speed, service life will be 20,000 hours.
(Applied to the output side bearing, at radial load 0)
- ※ 8 The maximum radial load the reducer can accept.
- ※ 9 The maximum axial load the reducer can accept.
- ※ 10 The weight may vary slightly model to model

EVB-090

Frame size	Stage	Ratio	※1	※2	※3	※4	※5	※6	※7	
			Nominal output torque [Nm]	Maximum output torque [Nm]	Emergency stop torque [Nm]	Nominal input speed [rpm]	Maximum input speed [rpm]	Permitted radial load [N]	Permitted axial load [N]	
090	2	3	45	65	130	3000	6000	810	930	
		4	60	90	170	3000	6000	890	1100	
		5	65	90	220	3000	6000	960	1200	
		6	65	90	220	3000	6000	1000	1300	
		7	65	90	220	3000	6000	1100	1300	
		8	65	90	220	3000	6000	1100	1400	
		9	45	65	170	3000	6000	1200	1500	
		10	45	65	170	3000	6000	1200	1600	
		3	15	45	65	170	3000	6000	1400	1900
			16	65	110	220	3000	6000	1400	1900
	20		65	110	220	3000	6000	1500	2100	
	25		65	110	220	3000	6000	1600	2200	
	28		65	110	220	3000	6000	1700	2200	
	30		45	65	170	3000	6000	1700	2200	
	35		65	110	220	3000	6000	1800	2200	
	40		65	110	220	3000	6000	1900	2200	
	45		45	65	170	3000	6000	2000	2200	
	50		65	110	220	3000	6000	2100	2200	
	60	65	110	220	3000	6000	2200	2200		
	70	65	110	220	3000	6000	2300	2200		
80	65	110	220	3000	6000	2400	2200			
90	45	65	170	3000	6000	2400	2200			
100	45	65	170	3000	6000	2400	2200			

Frame size	Stage	Ratio	※8	※9	※10	Moment of inertia (≤ φ 8)	Moment of inertia (≤ φ 14)	Moment of inertia (≤ φ 19)	Moment of inertia (≤ φ 28)		
			Maximum radial load [N]	Maximum axial load [N]	Weight [kg]	[kg·cm ²]	[kg·cm ²]	[kg·cm ²]	[kg·cm ²]		
090	2	3	2400	2200	5.1	-	2.12	2.45	4.57		
		4	2400	2200		-	1.89	2.22	4.35		
		5	2400	2200		-	1.80	2.13	4.26		
		6	2400	2200		-	1.76	2.09	4.21		
		7	2400	2200		-	1.73	2.06	4.18		
		8	2400	2200		-	1.71	2.04	4.17		
		9	2400	2200		-	1.70	2.03	4.16		
		10	2400	2200		-	1.69	2.02	4.15		
		3	15	2400		2200	4.4	0.34	0.41	0.60	-
			16	2400		2200		0.38	0.46	0.65	-
	20		2400	2200	0.33	0.40		0.59	-		
	25		2400	2200	0.32	0.40		0.59	-		
	28		2400	2200	0.37	0.45		0.64	-		
	30		2400	2200	0.25	0.33		0.51	-		
	35		2400	2200	0.32	0.40		0.59	-		
	40		2400	2200	0.25	0.32		0.51	-		
	45		2400	2200	0.32	0.39		0.58	-		
	50		2400	2200	0.25	0.32		0.51	-		
	60	2400	2200	0.25	0.32	0.51	-				
	70	2400	2200	0.25	0.32	0.51	-				
80	2400	2200	0.25	0.32	0.51	-					
90	2400	2200	0.25	0.32	0.51	-					
100	2400	2200	0.25	0.32	0.51	-					

- ※ 1 With nominal input speed, service life is 20,000 hours.
- ※ 2 The maximum torque when starting and stopping.
- ※ 3 The maximum torque when it receives shock (up to 1,000 times)
- ※ 4 The maximum average input speed.
- ※ 5 The maximum momentary input speed.
- ※ 6 With this load and nominal input speed, service life will be 20,000 hours.
(Applied to the output shaft center, at axial load 0)
- ※ 7 With this load and nominal input speed, service life will be 20,000 hours.
(Applied to the output side bearing, at radial load 0)
- ※ 8 The maximum radial load the reducer can accept.
- ※ 9 The maximum axial load the reducer can accept.
- ※ 10 The weight may vary slightly model to model

EVB-115

Frame size	Stage	Ratio	※1	※2	※3	※4	※5	※6	※7	
			Nominal output torque [Nm]	Maximum output torque [Nm]	Emergency stop torque [Nm]	Nominal input speed [rpm]	Maximum input speed [rpm]	Permitted radial load [N]	Permitted axial load [N]	
115	2	3	75	150	320	3000	6000	1300	1500	
		4	100	200	430	3000	6000	1500	1700	
		5	120	240	500	3000	6000	1600	1900	
		6	150	300	550	3000	6000	1700	2000	
		7	150	300	550	3000	6000	1800	2100	
		8	150	300	550	3000	6000	1900	2300	
		9	110	200	450	3000	6000	1900	2400	
		10	110	200	450	3000	6000	2000	2500	
		3	15	110	200	450	3000	6000	2300	3000
			16	130	260	550	3000	6000	2300	3100
	20		150	300	550	3000	6000	2500	3400	
	25		150	300	550	3000	6000	2700	3700	
	28		150	300	550	3000	6000	2800	3900	
	30		110	200	450	3000	6000	2900	3900	
	35		150	300	550	3000	6000	3000	3900	
	40		150	300	550	3000	6000	3200	3900	
	45		110	200	450	3000	6000	3300	3900	
	50		150	300	550	3000	6000	3400	3900	
	60	150	300	550	3000	6000	3600	3900		
	70	150	300	550	3000	6000	3800	3900		
80	150	300	550	3000	6000	4000	3900			
90	110	200	450	3000	6000	4200	3900			
100	110	200	450	3000	6000	4300	3900			

Frame size	Stage	Ratio	※8	※9	※10	Moment of inertia ($\leq \phi 14$) [kg·cm ²]	Moment of inertia ($\leq \phi 19$) [kg·cm ²]	Moment of inertia ($\leq \phi 28$) [kg·cm ²]	Moment of inertia ($\leq \phi 38$) [kg·cm ²]		
			Maximum radial load [N]	Maximum axial load [N]	Weight [kg]						
115	2	3	4300	3900	10.4	—	6.74	8.34	15.41		
		4	4300	3900		—	5.49	7.08	14.15		
		5	4300	3900		—	5.02	6.61	13.69		
		6	4300	3900		—	4.77	6.36	13.43		
		7	4300	3900		—	4.65	6.24	13.31		
		8	4300	3900		—	4.55	6.14	13.22		
		9	4300	3900		—	4.49	6.08	13.16		
		10	4300	3900		—	4.46	6.05	13.12		
		3	15	4300		3900	10.1	2.25	2.58	4.70	—
			16	4300		3900		2.46	2.79	4.91	—
	20		4300	3900	2.20	2.53		4.65	—		
	25		4300	3900	2.18	2.51		4.64	—		
	28		4300	3900	2.40	2.73		4.86	—		
	30		4300	3900	1.87	2.20		4.33	—		
	35		4300	3900	2.16	2.49		4.62	—		
	40		4300	3900	1.86	2.19		4.32	—		
	45		4300	3900	2.15	2.48		4.61	—		
	50		4300	3900	1.86	2.19		4.31	—		
	60	4300	3900	1.85	2.18	4.31	—				
	70	4300	3900	1.85	2.18	4.31	—				
80	4300	3900	1.85	2.18	4.31	—					
90	4300	3900	1.85	2.18	4.31	—					
100	4300	3900	1.85	2.18	4.31	—					

- ※ 1 With nominal input speed, service life is 20,000 hours.
- ※ 2 The maximum torque when starting and stopping.
- ※ 3 The maximum torque when it receives shock (up to 1,000 times)
- ※ 4 The maximum average input speed.
- ※ 5 The maximum momentary input speed.
- ※ 6 With this load and nominal input speed, service life will be 20,000 hours.
(Applied to the output shaft center, at axial load 0)
- ※ 7 With this load and nominal input speed, service life will be 20,000 hours.
(Applied to the output side bearing, at radial load 0)
- ※ 8 The maximum radial load the reducer can accept.
- ※ 9 The maximum axial load the reducer can accept.
- ※ 10 The weight may vary slightly model to model

EVB-140

Frame size	Stage	Ratio	※1	※2	※3	※4	※5	※6	※7	
			Nominal output torque [Nm]	Maximum output torque [Nm]	Emergency stop torque [Nm]	Nominal input speed [rpm]	Maximum input speed [rpm]	Permitted radial load [N]	Permitted axial load [N]	
140	2	3	130	260	700	2000	4000	3200	2400	
		4	170	340	950	2000	4000	3500	2700	
		5	200	400	1100	2000	4000	3800	3000	
		6	260	520	1100	2000	4000	4000	3300	
		7	300	600	1100	2000	4000	4200	3500	
		8	300	600	1100	2000	4000	4400	3700	
		9	200	400	750	2000	4000	4600	3900	
		10	200	400	750	2000	4000	4700	4100	
		3	15	200	400	750	2000	4000	5400	4900
			16	300	600	1100	2000	4000	5500	5000
	20		300	600	1100	2000	4000	6000	5500	
	25		300	600	1100	2000	4000	6400	6100	
	28		300	600	1100	2000	4000	6700	6400	
	30		200	400	750	2000	4000	6800	6600	
	35		300	600	1100	2000	4000	7200	7000	
	40		300	600	1100	2000	4000	7500	7500	
	45		200	400	750	2000	4000	7800	7900	
	50		300	600	1100	2000	4000	8100	8200	
	60	300	600	1100	2000	4000	8600	8200		
	70	300	600	1100	2000	4000	9100	8200		
80	300	600	1100	2000	4000	9100	8200			
90	200	400	750	2000	4000	9100	8200			
100	200	400	750	2000	4000	9100	8200			

Frame size	Stage	Ratio	※8	※9	※10	Moment of inertia (≤ φ 19)	Moment of inertia (≤ φ 28)	Moment of inertia (≤ φ 38)	Moment of inertia (≤ φ 48)		
			Maximum radial load [N]	Maximum axial load [N]	Weight [kg]	[kg·cm ²]	[kg·cm ²]	[kg·cm ²]	[kg·cm ²]		
140	2	3	9100	8200	19.1	-	23.13	27.50	40.73		
		4	9100	8200		-	18.57	22.94	36.17		
		5	9100	8200		-	16.91	21.28	34.51		
		6	9100	8200		-	16.01	20.38	33.61		
		7	9100	8200		-	15.58	19.95	33.18		
		8	9100	8200		-	15.23	19.61	32.84		
		9	9100	8200		-	14.77	19.41	32.37		
		10	9100	8200		-	14.66	19.03	32.26		
		3	15	9100		8200	19.6	6.40	8.00	15.07	-
			16	9100		8200		7.29	8.88	15.96	-
	20		9100	8200	6.22	7.81		14.89	-		
	25		9100	8200	6.15	7.75		14.82	-		
	28		9100	8200	7.09	8.68		15.76	-		
	30		9100	8200	4.99	6.58		13.66	-		
	35		9100	8200	6.09	7.69		14.76	-		
	40		9100	8200	4.95	6.54		13.61	-		
	45		9100	8200	6.07	7.66		14.74	-		
	50		9100	8200	4.93	6.52		13.59	-		
	60	9100	8200	4.92	6.51	13.59	-				
	70	9100	8200	4.91	6.51	13.58	-				
80	9100	8200	4.91	6.50	13.58	-					
90	9100	8200	4.91	6.50	13.57	-					
100	9100	8200	4.91	6.50	13.57	-					

- ※ 1 With nominal input speed, service life is 20,000 hours.
- ※ 2 The maximum torque when starting and stopping.
- ※ 3 The maximum torque when it receives shock (up to 1,000 times)
- ※ 4 The maximum average input speed.
- ※ 5 The maximum momentary input speed.
- ※ 6 With this load and nominal input speed, service life will be 20,000 hours.
(Applied to the output shaft center, at axial load 0)
- ※ 7 With this load and nominal input speed, service life will be 20,000 hours.
(Applied to the output side bearing, at radial load 0)
- ※ 8 The maximum radial load the reducer can accept.
- ※ 9 The maximum axial load the reducer can accept.
- ※ 10 The weight may vary slightly model to model

EVB-060 2stage

Input shaft bore $\leq \phi 8$

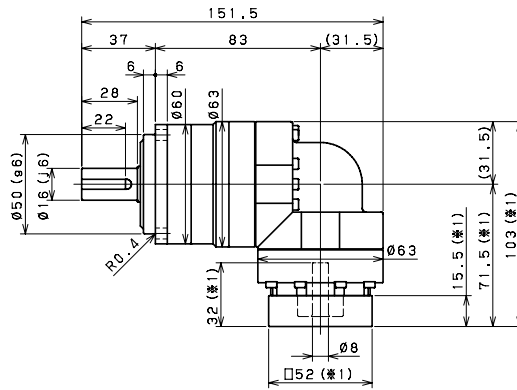
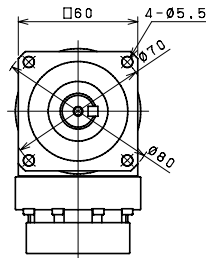

Input shaft bore $\leq \phi 14$

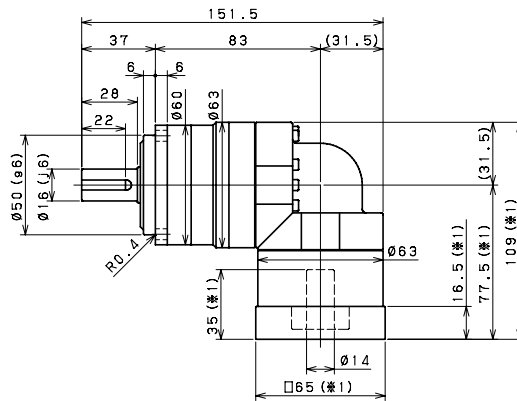
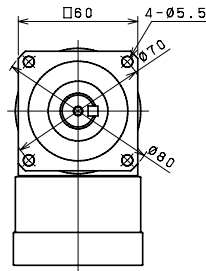

Input shaft bore $\leq \phi 19$

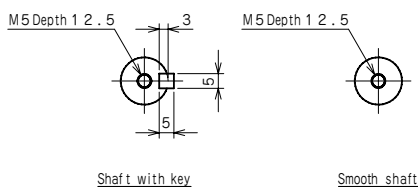
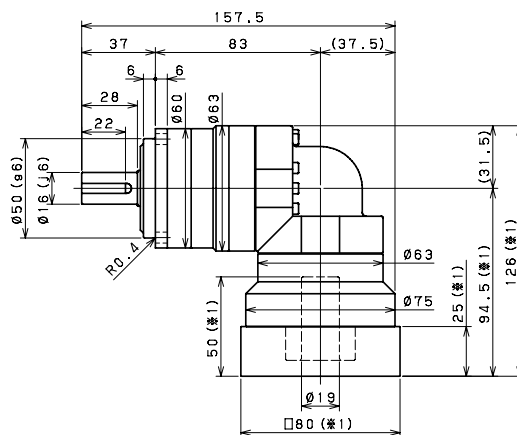
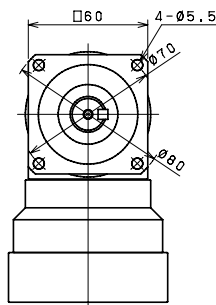

- *1 Length will vary depending on motor.
- *2 Bushing will be inserted to adapt to motor shaft.

EVB-060 3stage

Input shaft bore $\leq \phi 8$

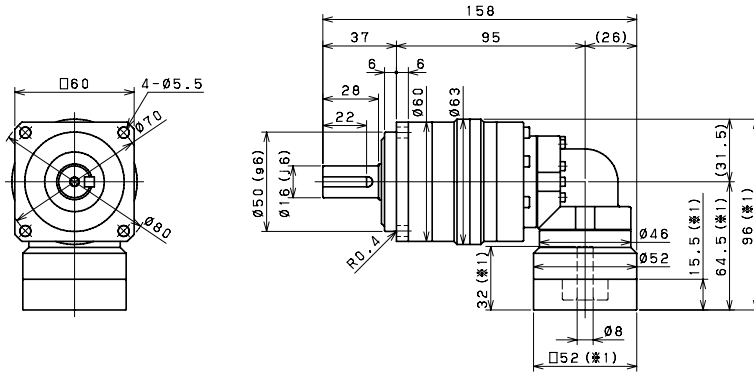

Input shaft bore $\leq \phi 14$

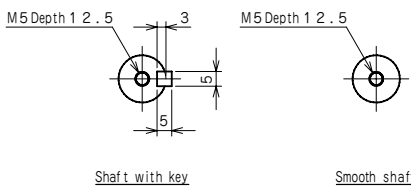
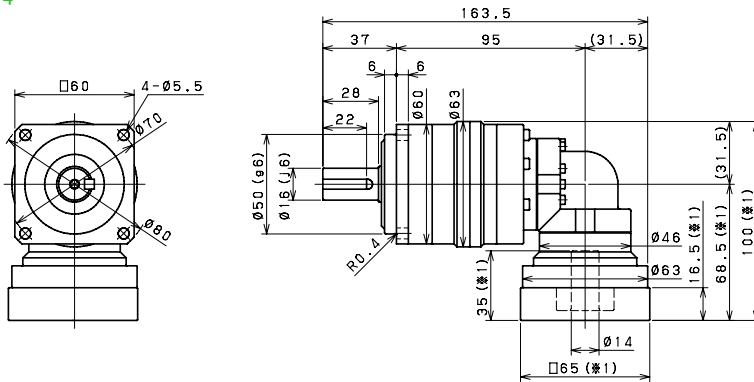

- ※ 1 Length will vary depending on motor.
- ※ 2 Bushing will be inserted to adapt to motor shaft.

EVB-090 2stage

Input shaft bore $\leq \phi 14$

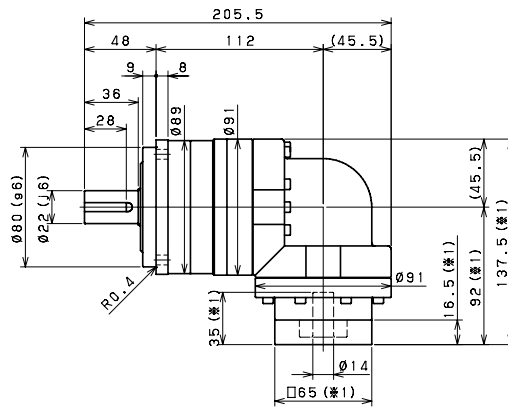
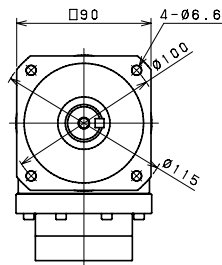

Input shaft bore $\leq \phi 19$

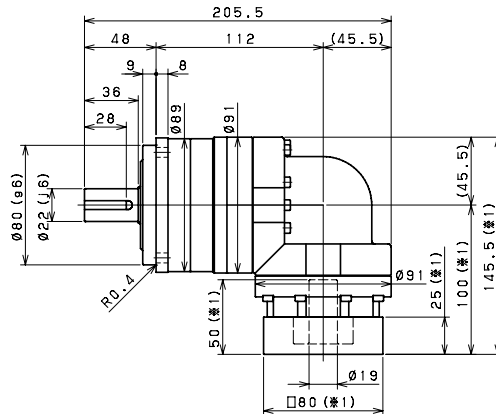
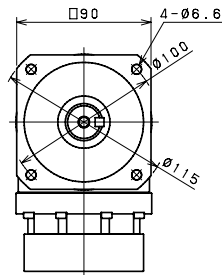

Input shaft bore $\leq \phi 28$

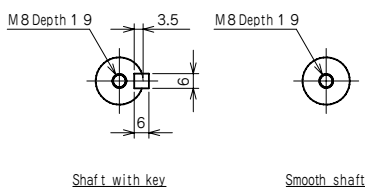
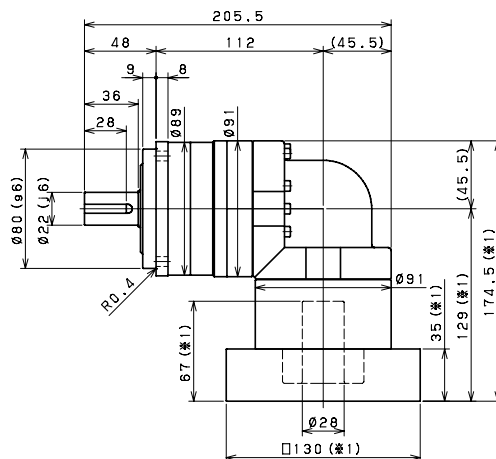
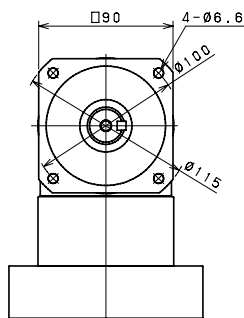

- ※ 1 Length will vary depending on motor.
- ※ 2 Bushing will be inserted to adapt to motor shaft.

EVB-090 3stage

Input shaft bore $\leq \phi 8$

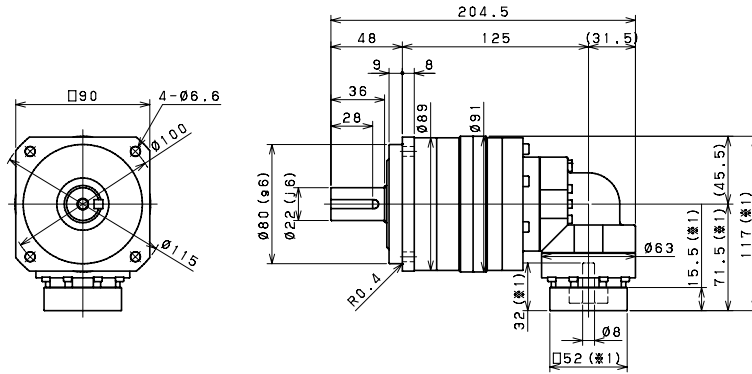

Input shaft bore $\leq \phi 14$

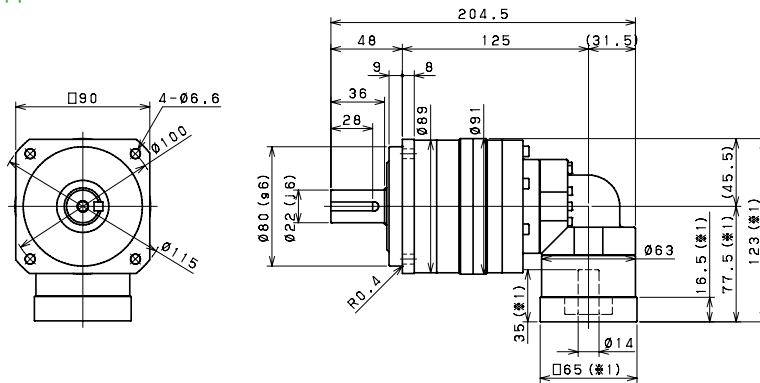

Input shaft bore $\leq \phi 19$

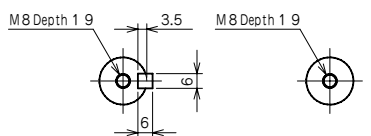
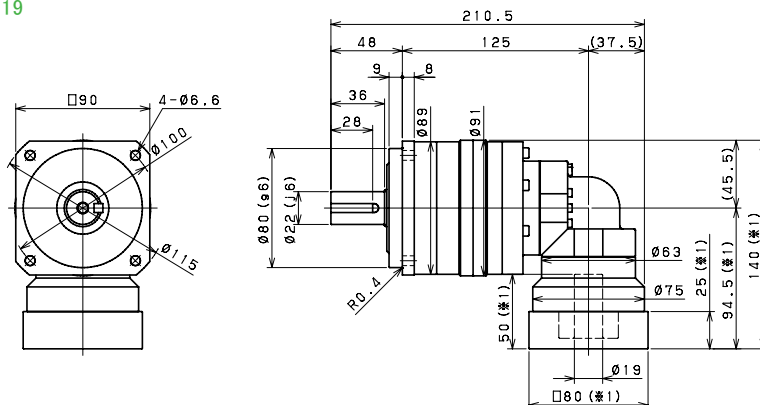

Shaft with key

Smooth shaft

- ※ 1 Length will vary depending on motor.
- ※ 2 Bushing will be inserted to adapt to motor shaft.

EVB-115 2stage

Input shaft bore $\leq \phi 19$

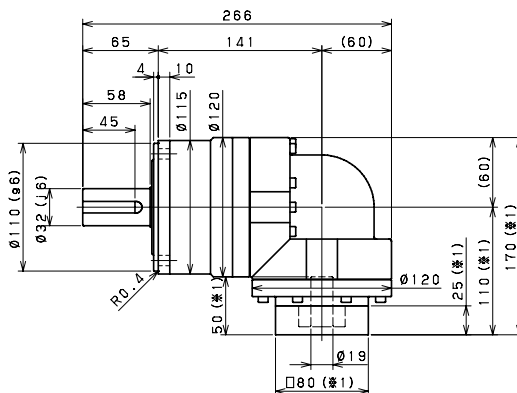
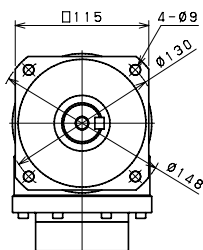

Input shaft bore $\leq \phi 28$

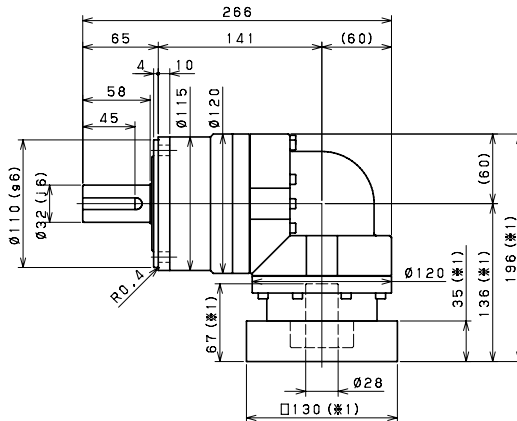
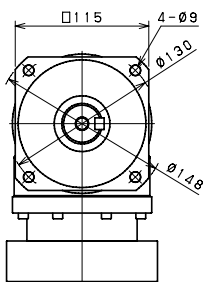

Input shaft bore $\leq \phi 38$

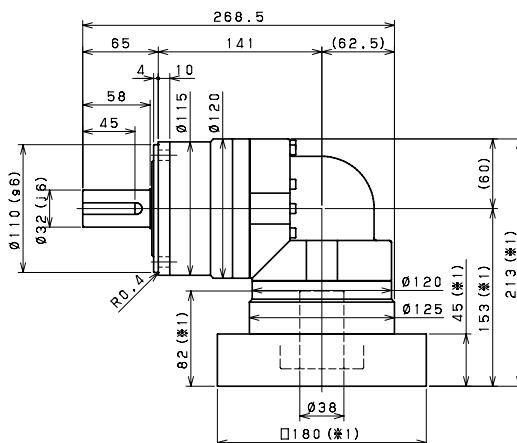
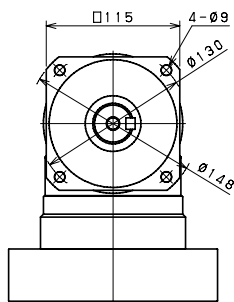

M 1.2 Depth 2.8

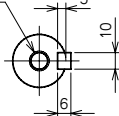

Shaft with key

M 1.2 Depth 2.8



Smooth shaft

※ 1 Length will vary depending on motor.

※ 2 Bushing will be inserted to adapt to motor shaft.

EVB-115 3stage

Input shaft bore $\leq \phi 14$

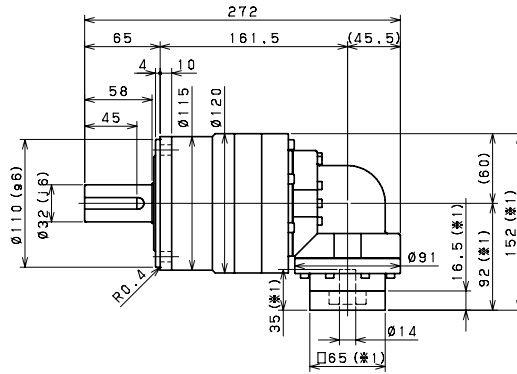
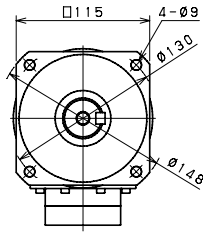

Input shaft bore $\leq \phi 19$

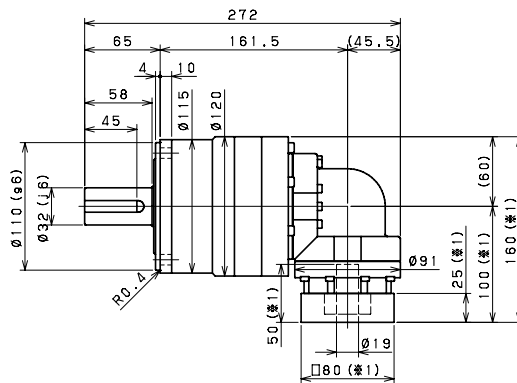
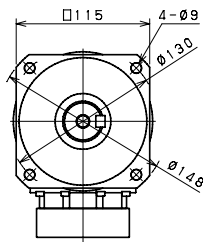

Input shaft bore $\leq \phi 28$

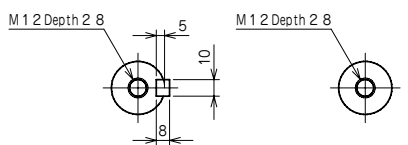
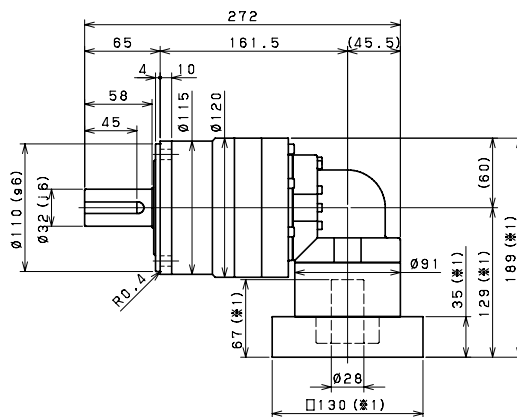
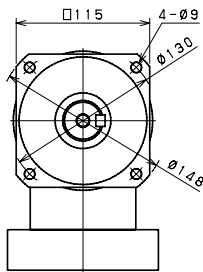

Shaft with key

Smooth shaft

- ※ 1 Length will vary depending on motor.
- ※ 2 Bushing will be inserted to adapt to motor shaft.

EVB-140 2stage

Input shaft bore $\leq \phi 28$

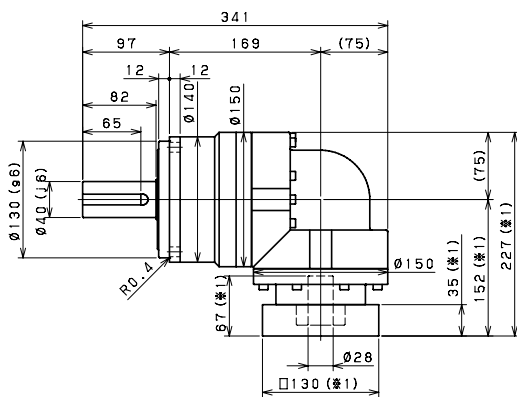
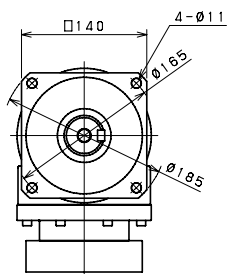

Input shaft bore $\leq \phi 38$

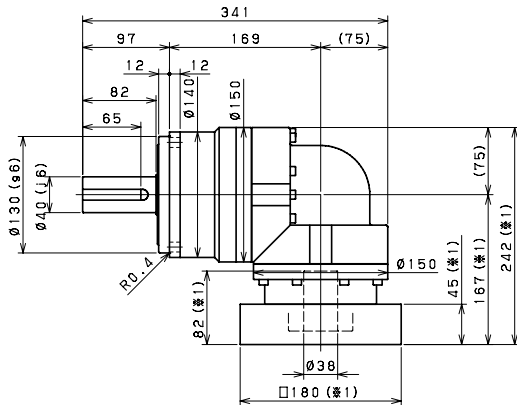
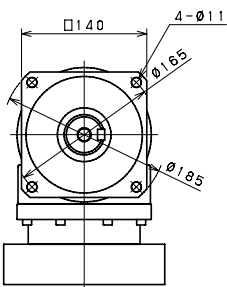

Input shaft bore $\leq \phi 48$

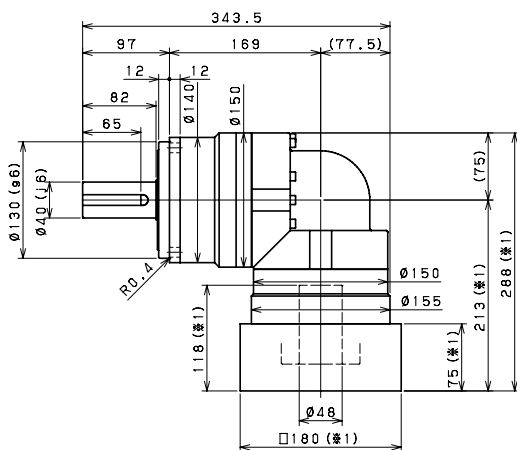
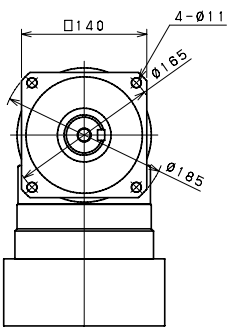

M 1.6 Depth 3.6

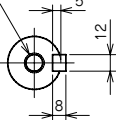

Shaft with key

M 1.6 Depth 3.6



Smooth shaft

※ 1 Length will vary depending on motor.

※ 2 Bushing will be inserted to adapt to motor shaft.

EVB-140 3stage

xInput shaft bore $\leq \phi 19$

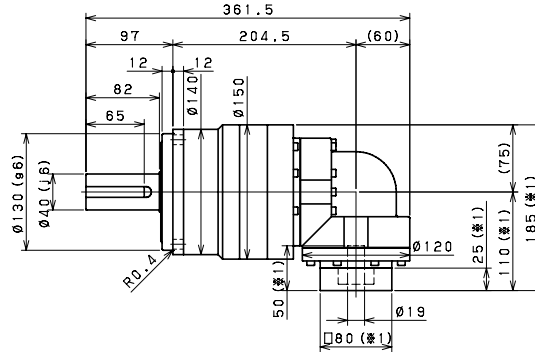
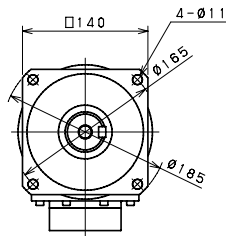

Input shaft bore $\leq \phi 28$

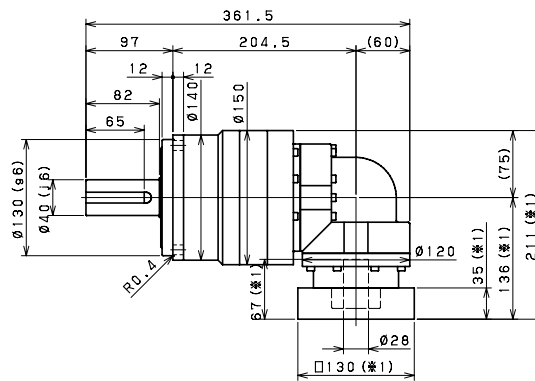
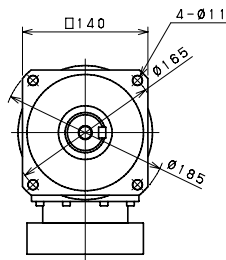

Input shaft bore $\leq \phi 38$

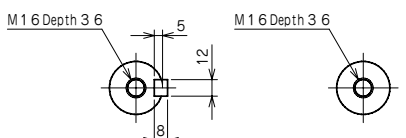
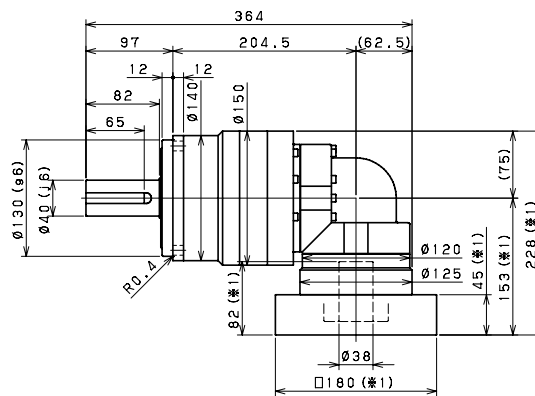
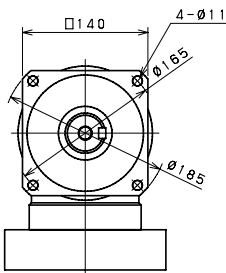

Shaft with key

Smooth shaft

- ※1 Length will vary depending on motor.
- ※2 Bushing will be inserted to adapt to motor shaft.

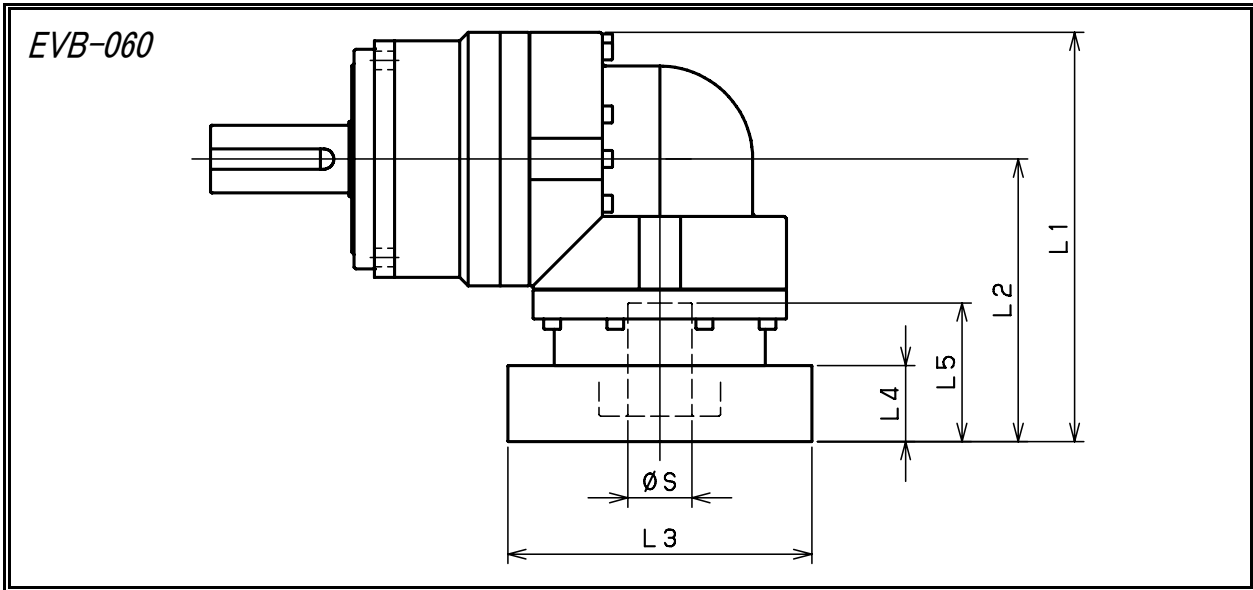

Model number	** : Adapter code	Single					Double				
		L1	L2	L3	L4	L5	L1	L2	L3	L4	L5
EVB-060-□-□-8** (S ≤ 8)	AA·AC·AD·AF·AG	103	71.5	□52	15.5	32	96	64.5	□52	15.5	32
	AB·AE·AH·AJ·AK	108	76.5	□52	20.5	37	101	69.5	□52	20.5	37
	BA·BB·BD·BE	103	71.5	□60	15.5	32	96	64.5	□60	15.5	32
	BC·BF	108	76.5	□60	20.5	37	101	69.5	□60	20.5	37
	CA	108	76.5	□70	20.5	37	101	69.5	□70	20.5	37
EVB-060-□-□-14** (8 < S ≤ 14)	BA·BB·BD·BE·BF·BG·BJ·BK	109	77.5	□65	16.5	35	100	68.5	□65	16.5	35
	BC·BH	114	82.5	□65	21.5	40	105	73.5	□65	21.5	40
	BL	119	87.5	□65	26.5	45	110	78.5	□65	26.5	45
	CA	109	77.5	□70	16.5	35	100	68.5	□70	16.5	35
	CB	114	82.5	□70	21.5	40	105	73.5	□70	21.5	40
	DA·DB·DC·DD·DF·DH	109	77.5	□80	16.5	35	100	68.5	□80	16.5	35
	DE	114	82.5	□80	21.5	40	105	73.5	□80	21.5	40
	DG	119	87.5	□80	26.5	45	110	78.5	□80	26.5	45
	EA·EB·EC	109	77.5	□90	16.5	35	100	68.5	□90	16.5	35
	ED	119	87.5	□90	26.5	45	110	78.5	□90	26.5	45
	FA	109	77.5	□100	16.5	35	100	68.5	□100	16.5	35
	GA	109	77.5	□115	16.5	35	100	68.5	□115	16.5	35
EVB-060-□-□-19** (14 < S ≤ 19)	DA·DB·DC	126	94.5	□80	25	50					
	DD	136	104.5	□80	35	60					
	DE	131	99.5	□80	30	55					
	EA	131	99.5	□90	30	55					
	EB	126	94.5	□90	25	50					
	EC	136	104.5	□90	35	60					
	FA	126	94.5	□100	25	50					
	FB	136	104.5	□100	35	60					
	GA·GC	131	99.5	□115	30	55					
	GB·GD	126	94.5	□115	25	50					
	HA	126	94.5	□130	25	50					
	HB	141	109.5	□130	40	65					
HC·HD·HE	131	99.5	□130	30	55						

※ 1 Single reduction : 1/3 ~ 1/10, Double reduction : 1/15 ~ 1/100
 ※ 2 Bushing will be inserted to adapt to motor shaft.

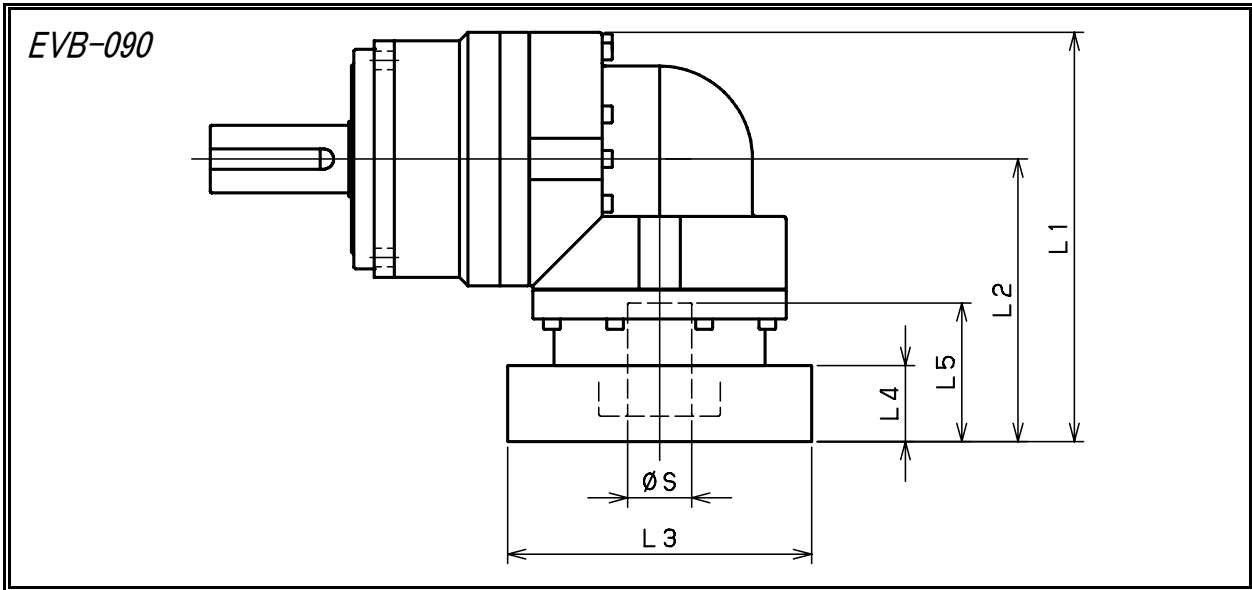

Model number	**: Adapter code	Single					Double				
		L1	L2	L3	L4	L5	L1	L2	L3	L4	L5
EVB-090-□-□-8** (S ≤ 8)	AA·AC·AD·AF·AG	/	/	/	/	/	117	71.5	□52	15.5	32
	AB·AE·AH·AJ·AK	/	/	/	/	/	122	76.5	□52	20.5	37
	BA·BB·BD·BE	/	/	/	/	/	117	71.5	□60	15.5	32
	BC·BF	/	/	/	/	/	122	76.5	□60	20.5	37
	CA	/	/	/	/	/	122	76.5	□70	20.5	37
EVB-090-□-□-14** (8 < S ≤ 14)	BA·BB·BD·BE·BF·BG·BJ·BK	137.5	92	□65	16.5	35	123	77.5	□65	16.5	35
	BC·BH	142.5	97	□65	21.5	40	128	82.5	□65	21.5	40
	BL	147.5	102	□65	26.5	45	133	87.5	□65	26.5	45
	CA	137.5	92	□70	16.5	35	123	77.5	□70	16.5	35
	CB	142.5	97	□70	21.5	40	128	82.5	□70	21.5	40
	DA·DB·DC·DD·DF·DH	137.5	92	□80	16.5	35	123	77.5	□80	16.5	35
	DE	142.5	97	□80	21.5	40	128	82.5	□80	21.5	40
	DG	147.5	102	□80	26.5	45	133	87.5	□80	26.5	45
	EA·EB·EC	137.5	92	□90	16.5	35	123	77.5	□90	16.5	35
	ED	147.5	102	□90	26.5	45	133	87.5	□90	26.5	45
	FA	137.5	92	□100	16.5	35	123	77.5	□100	16.5	35
	GA	137.5	92	□115	16.5	35	123	77.5	□115	16.5	35
EVB-090-□-□-19** (14 < S ≤ 19)	DA·DB·DC	145.5	100	□80	25	50	140	94.5	□80	25	50
	DD	155.5	110	□80	35	60	150	104.5	□80	35	60
	DE	150.5	105	□80	30	55	145	99.5	□80	30	55
	EA	150.5	105	□90	30	55	145	99.5	□90	30	55
	EB	145.5	100	□90	25	50	140	94.5	□90	25	50
	EC	155.5	110	□90	35	60	150	104.5	□90	35	60
	FA	145.5	100	□100	25	50	140	94.5	□100	25	50
	FB	155.5	110	□100	35	60	150	104.5	□100	35	60
	GA·GC	150.5	105	□115	30	55	145	99.5	□115	30	55
	GB·GD	145.5	100	□115	25	50	140	94.5	□115	25	50
	HA	145.5	100	□130	25	50	140	94.5	□130	25	50
	HB	160.5	115	□130	40	65	155	109.5	□130	40	65
HC·HD·HE	150.5	105	□130	30	55	145	99.5	□130	30	55	
EVB-090-□-□-28** (19 < S ≤ 28)	FA·FB·FC	174.5	129	□100	35	67	/	/	/	/	/
	GA·GB·GC·GD·GE·GF·GG	174.5	129	□115	35	67	/	/	/	/	/
	HA·HC·HD	174.5	129	□130	35	67	/	/	/	/	/
	HB	184.5	139	□130	45	77	/	/	/	/	/
	JA·JB·JC	174.5	129	□150	35	67	/	/	/	/	/
	KA·KB	174.5	129	□180	35	67	/	/	/	/	/
	LA	174.5	129	□200	35	67	/	/	/	/	/
MA	174.5	129	□220	35	67	/	/	/	/	/	

※ 1 Single reduction : 1/3 ~ 1/10, Double reduction : 1/15 ~ 1/100

※ 2 Bushing will be inserted to adapt to motor shaft.

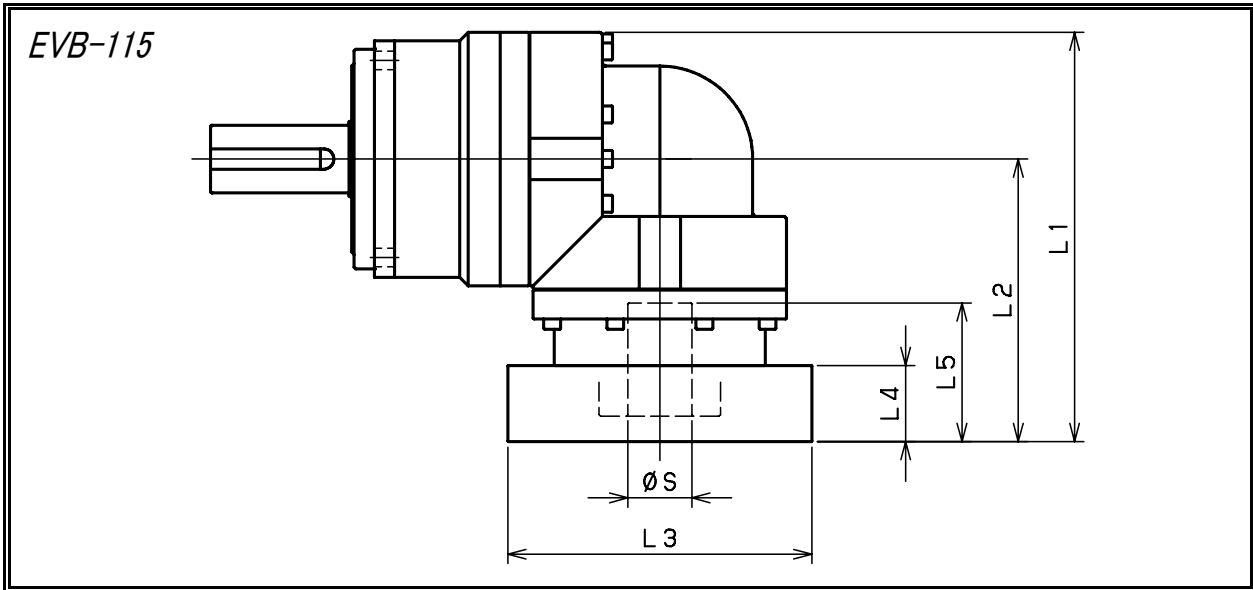

Model number	** : Adapter code	Single					Double				
		L1	L2	L3	L4	L5	L1	L2	L3	L4	L5
EVB-115-□-□-14** (S ≤ 14)	BA·BB·BD·BE·BF·BG·BJ·BK	/	/	/	/	/	152	92	□65	16.5	35
	BC·BH	/	/	/	/	/	157	97	□65	21.5	40
	BL	/	/	/	/	/	162	102	□65	26.5	45
	CA	/	/	/	/	/	152	92	□70	16.5	35
	CB	/	/	/	/	/	157	97	□70	21.5	40
	DA·DB·DC·DD·DF·DH	/	/	/	/	/	152	92	□80	16.5	35
	DE	/	/	/	/	/	157	97	□80	21.5	40
	DG	/	/	/	/	/	162	102	□80	26.5	45
	EA·EB·EC	/	/	/	/	/	152	92	□90	16.5	35
	ED	/	/	/	/	/	162	102	□90	26.5	45
FA	/	/	/	/	/	152	92	□100	16.5	35	
GA	/	/	/	/	/	152	92	□115	16.5	35	
EVB-115-□-□-19** (14 < S ≤ 19)	DA·DB·DC	170	110	□80	25	50	160	100	□80	25	50
	DD	180	120	□80	35	60	170	110	□80	35	60
	DE	175	115	□80	30	55	165	105	□80	30	55
	EA	175	115	□90	30	55	165	105	□90	30	55
	EB	170	110	□90	25	50	160	100	□90	25	50
	EC	180	120	□90	35	60	170	110	□90	35	60
	FA	170	110	□100	25	50	160	100	□100	25	50
	FB	180	120	□100	35	60	170	110	□100	35	60
	GA·GC	175	115	□115	30	55	165	105	□115	30	55
	GB·GD	170	110	□115	25	50	160	100	□115	25	50
HA	170	110	□130	25	50	160	100	□130	25	50	
HB	185	125	□130	40	65	175	115	□130	40	65	
HC·HD·HE	175	115	□130	30	55	165	105	□130	30	55	
EVB-115-□-□-28** (19 < S ≤ 28)	FA·FB·FC	196	136	□100	35	67	189	129	□100	35	67
	GA·GB·GC·GD·GE·GF·GG	196	136	□115	35	67	189	129	□115	35	67
	HA·HC·HD	196	136	□130	35	67	189	129	□130	35	67
	HB	206	146	□130	45	77	199	139	□130	45	77
	JA·JB·JC	196	136	□150	35	67	189	129	□150	35	67
	KA·KB	196	136	□180	35	67	189	129	□180	35	67
	LA	196	136	□200	35	67	189	129	□200	35	67
MA	196	136	□220	35	67	189	129	□220	35	67	
EVB-115-□-□-38** (28 < S ≤ 38)	HA	213	153	□130	45	82	/	/	/	/	/
	HB	208	148	□130	40	77	/	/	/	/	/
	JA	213	153	□150	45	82	/	/	/	/	/
	KA·KB·KC	213	153	□180	45	82	/	/	/	/	/
	LA	213	153	□200	45	82	/	/	/	/	/
	LB	223	163	□200	55	92	/	/	/	/	/
	MA·MB	213	153	□220	45	82	/	/	/	/	/
NA	213	153	□250	45	82	/	/	/	/	/	

※1 Single reduction : 1/3 ~ 1/10, Double reduction : 1/15 ~ 1/100
 ※2 Bushing will be inserted to adapt to motor shaft.

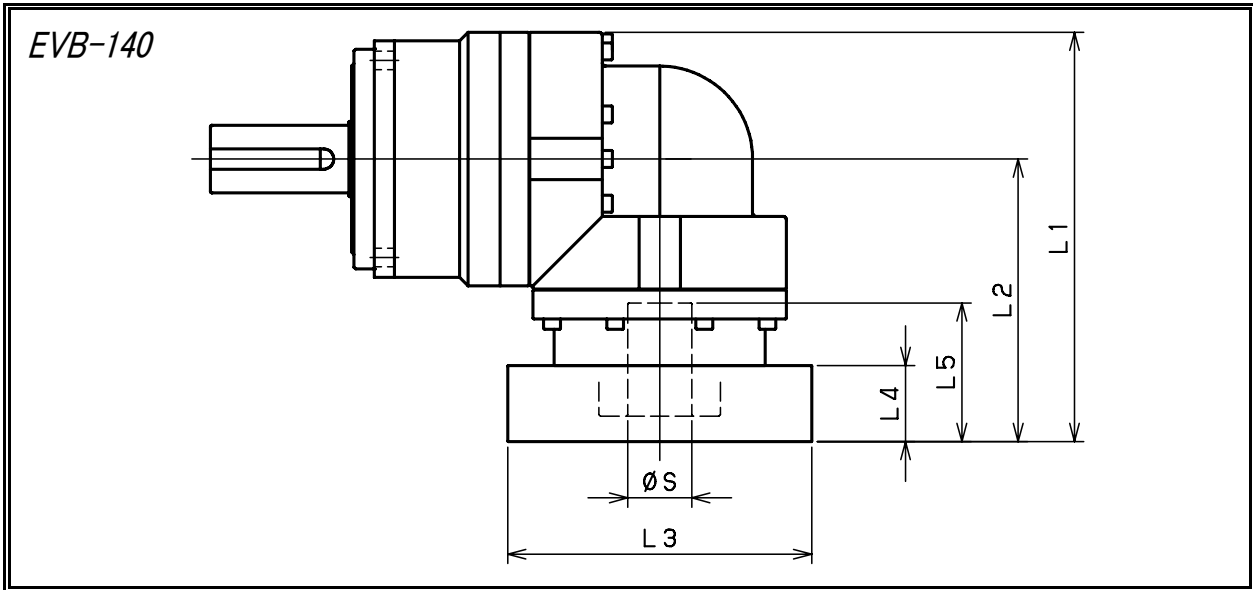

Model number	** : Adapter code	Single					Double				
		L1	L2	L3	L4	L5	L1	L2	L3	L4	L5
EVB-140-□-□-19** (S ≤ 19)	DA·DB·DC	/	/	/	/	/	185	110	□80	25	50
	DD	/	/	/	/	/	195	120	□80	35	60
	DE	/	/	/	/	/	190	115	□80	30	55
	EA	/	/	/	/	/	190	115	□90	30	55
	EB	/	/	/	/	/	185	110	□90	25	50
	EC	/	/	/	/	/	195	120	□90	35	60
	FA	/	/	/	/	/	185	110	□100	25	50
	FB	/	/	/	/	/	195	120	□100	35	60
	GA·GC	/	/	/	/	/	190	115	□115	30	55
	GB·GD	/	/	/	/	/	185	110	□115	25	50
	HA	/	/	/	/	/	185	110	□130	25	50
	HB	/	/	/	/	/	200	125	□130	40	65
	HC·HD·HE	/	/	/	/	/	190	115	□130	30	55
EVB-140-□-□-28** (19 < S ≤ 28)	FA·FB·FC	227	152	□100	35	67	211	136	□100	35	67
	GA·GB·GC·GD·GE·GF·GG	227	152	□115	35	67	211	136	□115	35	67
	HA·HC·HD	227	152	□130	35	67	211	136	□130	35	67
	HB	237	162	□130	45	77	221	146	□130	45	77
	JA·JB·JC	227	152	□150	35	67	211	136	□150	35	67
	KA·KB	227	152	□180	35	67	211	136	□180	35	67
	LA	227	152	□200	35	67	211	136	□200	35	67
MA	227	152	□220	35	67	211	136	□220	35	67	
EVB-140-□-□-38** (28 < S ≤ 38)	HA	242	167	□130	45	82	228	153	□130	45	82
	HB	237	162	□130	40	77	223	148	□130	40	77
	JA	242	167	□150	45	82	228	153	□150	45	82
	KA·KB·KC	242	167	□180	45	82	228	153	□180	45	82
	LA	242	167	□200	45	82	228	153	□200	45	82
	LB	252	177	□200	55	92	238	163	□200	55	92
	MA·MB	242	167	□220	45	82	228	153	□220	45	82
NA	242	167	□250	45	82	228	153	□250	45	82	
EVB-140-□-□-48** (38 < S ≤ 48)	KB·KC	268	193	□180	55	98	/	/	/	/	/
	KA	288	213	□180	75	118	/	/	/	/	/
	LA	268	193	□200	55	98	/	/	/	/	/
	MA	268	193	□220	55	98	/	/	/	/	/
	MB	288	213	□220	75	118	/	/	/	/	/
	NA	288	213	□250	75	118	/	/	/	/	/
PA	288	213	□280	75	118	/	/	/	/	/	

※ 1 Single reduction : 1/3 ~ 1/10, Double reduction : 1/15 ~ 1/100

※ 2 Bushing will be inserted to adapt to motor shaft.

SHIMPO

For servo motor
ABLE REDUCER

EVL Series



EVL series

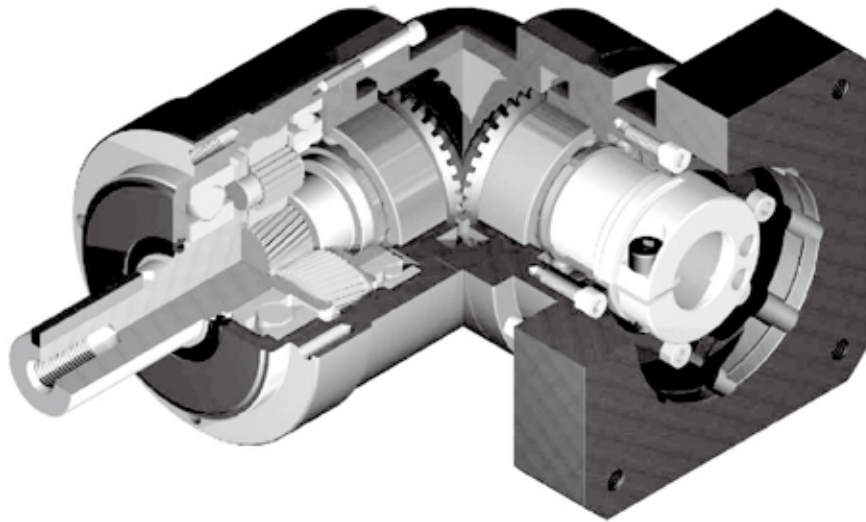

Space - saving

Right angle reducer using spiral bevel gear
Customer can locate the motor at 90 degree away from the reducer if required to save space.

High rigidity & torque

High rigidity & high torque was achieved by uncaged needle roller bearings.

Adapter-bushing connection

Can be attached to any motor all over the world.

No grease leakage

Perfect solution by high viscosity anti-separation grease.

Maintenance-free

No need to replace the grease for the life time.
Can be attached in any position.

EVL series

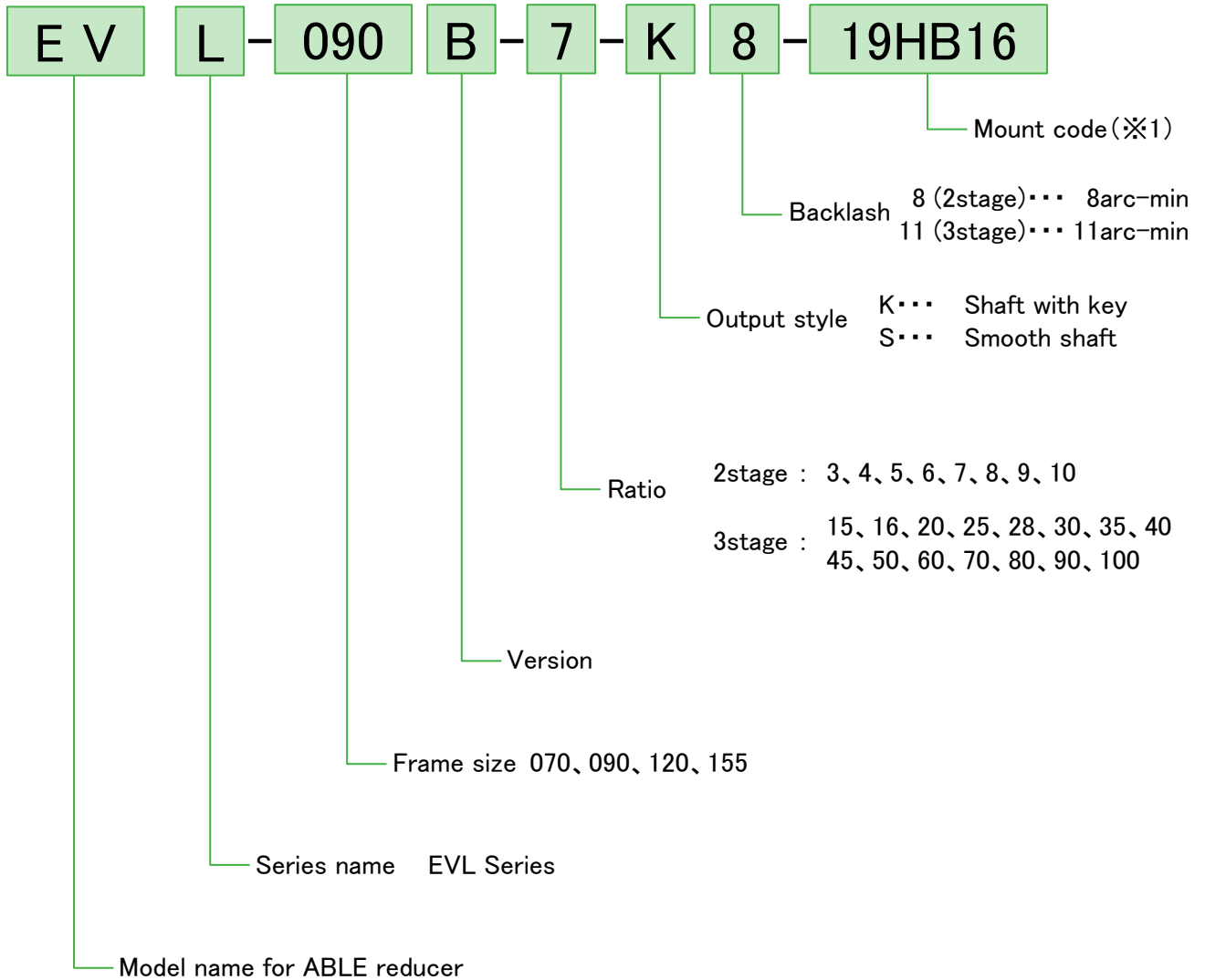

※1 Mount code

Mount code varies depending on the motor.
Please refer to reducer selection tool or contact us for more information.

Selection tool (English)
(<http://www.nidec-shimpo.co.jp/selection/eng/>)

EVL-070B

Frame size	Stage	Ratio	※1	※2	※3	※4	※5	※6	※7
			Nominal output torque [Nm]	Maximum output torque [Nm]	Emergency stop torque [Nm]	Nominal input speed [rpm]	Maximum input speed [rpm]	Permitted radial load [N]	Permitted axial load [N]
070B	2	3	12	24	50	3000	6000	430	310
		4	16	32	65	3000	6000	470	360
		5	22	40	80	3000	6000	510	390
		6	24	45	90	3000	6000	540	430
		7	24	45	90	3000	6000	570	460
		8	24	45	90	3000	6000	600	480
		9	16	32	65	3000	6000	620	510
	3	10	16	32	65	3000	6000	640	530
		15	16	32	65	3000	6000	740	630
		16	24	45	90	3000	6000	750	650
		20	24	45	90	3000	6000	810	720
		25	24	45	90	3000	6000	870	790
		28	24	45	90	3000	6000	910	830
		30	16	32	65	3000	6000	930	860
		35	24	45	90	3000	6000	980	920
		40	24	45	90	3000	6000	1000	970
		45	16	32	65	3000	6000	1100	1000
		50	24	45	90	3000	6000	1100	1100
		60	24	45	90	3000	6000	1200	1100
		70	24	45	90	3000	6000	1200	1100
80	24	45	90	3000	6000	1200	1100		
90	16	32	65	3000	6000	1200	1100		
100	16	32	65	3000	6000	1200	1100		

Frame size	Stage	Ratio	※8	※9	※10	Moment of inertia (≤ φ 8) [kg·cm ²]	Moment of inertia (≤ φ 14) [kg·cm ²]	Moment of inertia (≤ φ 19) [kg·cm ²]
			Maximum radial load [N]	Maximum axial load [N]	Weight [kg]			
070B	2	3	1200	1100	1.9	0.31	0.39	0.58
		4	1200	1100		0.27	0.34	0.53
		5	1200	1100		0.25	0.32	0.51
		6	1200	1100		0.24	0.31	0.50
		7	1200	1100		0.23	0.31	0.50
		8	1200	1100		0.23	0.31	0.50
		9	1200	1100		0.23	0.30	0.49
	3	10	1200	1100	0.23	0.30	0.49	
		15	1200	1100	1.7	0.073	0.118	—
		16	1200	1100		0.079	0.124	—
		20	1200	1100		0.071	0.116	—
		25	1200	1100		0.071	0.115	—
		28	1200	1100		0.077	0.122	—
		30	1200	1100		0.062	0.106	—
		35	1200	1100		0.070	0.115	—
		40	1200	1100		0.061	0.106	—
		45	1200	1100		0.070	0.115	—
		50	1200	1100		0.061	0.106	—
		60	1200	1100		0.061	0.106	—
		70	1200	1100		0.061	0.105	—
80	1200	1100	0.061	0.105		—		
90	1200	1100	0.061	0.105	—			
100	1200	1100	0.061	0.105	—			

- ※ 1 With nominal input speed, service life is 20,000 hours.
- ※ 2 The maximum torque when starting and stopping.
- ※ 3 The maximum torque when it receives shock (up to 1,000 times)
- ※ 4 The maximum average input speed.
- ※ 5 The maximum momentary input speed.
- ※ 6 With this load and nominal input speed, service life will be 20,000 hours.
(Applied to the output shaft center, at axial load 0)
- ※ 7 With this load and nominal input speed, service life will be 20,000 hours.
(Applied to the output side bearing, at radial load 0)
- ※ 8 The maximum radial load the reducer can accept.
- ※ 9 The maximum axial load the reducer can accept.
- ※ 10 The weight may vary slightly model to model

ABLE REDUCER

EVL-090B

Frame size	Stage	Ratio	※1	※2	※3	※4	※5	※6	※7	
			Nominal output torque [Nm]	Maximum output torque [Nm]	Emergency stop torque [Nm]	Nominal input speed [rpm]	Maximum input speed [rpm]	Permitted radial load [N]	Permitted axial load [N]	
090B	2	3	45	65	130	3000	6000	810	930	
		4	60	90	170	3000	6000	890	1100	
		5	65	90	220	3000	6000	960	1200	
		6	65	90	220	3000	6000	1000	1300	
		7	65	90	220	3000	6000	1100	1300	
		8	65	90	220	3000	6000	1100	1400	
		9	45	65	170	3000	6000	1200	1500	
		10	45	65	170	3000	6000	1200	1600	
		3	15	45	65	170	3000	6000	1400	1900
			16	65	110	220	3000	6000	1400	1900
	20		65	110	220	3000	6000	1500	2100	
	25		65	110	220	3000	6000	1600	2200	
	28		65	110	220	3000	6000	1700	2200	
	30		45	65	170	3000	6000	1700	2200	
	35		65	110	220	3000	6000	1800	2200	
	40		65	110	220	3000	6000	1900	2200	
	45		45	65	170	3000	6000	2000	2200	
	50		65	110	220	3000	6000	2100	2200	
	60	65	110	220	3000	6000	2200	2200		
	70	65	110	220	3000	6000	2300	2200		
80	65	110	220	3000	6000	2400	2200			
90	45	65	170	3000	6000	2400	2200			
100	45	65	170	3000	6000	2400	2200			

Frame size	Stage	Ratio	※8	※9	※10	Moment of inertia (≤ φ 8) [kg·cm ²]	Moment of inertia (≤ φ 14) [kg·cm ²]	Moment of inertia (≤ φ 19) [kg·cm ²]	Moment of inertia (≤ φ 28) [kg·cm ²]		
			Maximum radial load [N]	Maximum axial load [N]	Weight [kg]						
090B	2	3	2400	2200	4.9	-	2.12	2.45	4.57		
		4	2400	2200		-	1.89	2.22	4.35		
		5	2400	2200		-	1.80	2.13	4.26		
		6	2400	2200		-	1.76	2.09	4.21		
		7	2400	2200		-	1.73	2.06	4.18		
		8	2400	2200		-	1.71	2.04	4.17		
		9	2400	2200		-	1.70	2.03	4.16		
		10	2400	2200		-	1.69	2.02	4.15		
		3	15	2400		2200	4.3	0.34	0.41	0.60	-
			16	2400		2200		0.38	0.46	0.65	-
	20		2400	2200	0.33	0.40		0.59	-		
	25		2400	2200	0.32	0.40		0.59	-		
	28		2400	2200	0.37	0.45		0.64	-		
	30		2400	2200	0.25	0.33		0.51	-		
	35		2400	2200	0.32	0.40		0.59	-		
	40		2400	2200	0.25	0.32		0.51	-		
	45		2400	2200	0.32	0.39		0.58	-		
	50		2400	2200	0.25	0.32		0.51	-		
	60	2400	2200	0.25	0.32	0.51	-				
	70	2400	2200	0.25	0.32	0.51	-				
80	2400	2200	0.25	0.32	0.51	-					
90	2400	2200	0.25	0.32	0.51	-					
100	2400	2200	0.25	0.32	0.51	-					

- ※ 1 With nominal input speed, service life is 20,000 hours.
- ※ 2 The maximum torque when starting and stopping.
- ※ 3 The maximum torque when it receives shock (up to 1,000 times)
- ※ 4 The maximum average input speed.
- ※ 5 The maximum momentary input speed.
- ※ 6 With this load and nominal input speed, service life will be 20,000 hours.
(Applied to the output shaft center, at axial load 0)
- ※ 7 With this load and nominal input speed, service life will be 20,000 hours.
(Applied to the output side bearing, at radial load 0)
- ※ 8 The maximum radial load the reducer can accept.
- ※ 9 The maximum axial load the reducer can accept.
- ※ 10 The weight may vary slightly model to model

EVL-120B

Frame size	Stage	Ratio	※1	※2	※3	※4	※5	※6	※7	
			Nominal output torque [Nm]	Maximum output torque [Nm]	Emergency stop torque [Nm]	Nominal input speed [rpm]	Maximum input speed [rpm]	Permitted radial load [N]	Permitted axial load [N]	
120B	2	3	75	150	320	3000	6000	1300	1500	
		4	100	200	430	3000	6000	1500	1700	
		5	120	240	500	3000	6000	1600	1900	
		6	150	300	550	3000	6000	1700	2000	
		7	150	300	550	3000	6000	1800	2100	
		8	150	300	550	3000	6000	1900	2300	
		9	110	200	450	3000	6000	1900	2400	
		10	110	200	450	3000	6000	2000	2500	
		3	15	110	200	450	3000	6000	2300	3000
			16	130	260	550	3000	6000	2300	3100
	20		150	300	550	3000	6000	2500	3400	
	25		150	300	550	3000	6000	2700	3700	
	28		150	300	550	3000	6000	2800	3900	
	30		110	200	450	3000	6000	2900	3900	
	35		150	300	550	3000	6000	3000	3900	
	40		150	300	550	3000	6000	3200	3900	
	45		110	200	450	3000	6000	3300	3900	
	50		150	300	550	3000	6000	3400	3900	
	60	150	300	550	3000	6000	3600	3900		
	70	150	300	550	3000	6000	3800	3900		
80	150	300	550	3000	6000	4000	3900			
90	110	200	450	3000	6000	4200	3900			
100	110	200	450	3000	6000	4300	3900			

Frame size	Stage	Ratio	※8	※9	※10	Moment of inertia (≤ φ 14) [kg·cm ²]	Moment of inertia (≤ φ 19) [kg·cm ²]	Moment of inertia (≤ φ 28) [kg·cm ²]	Moment of inertia (≤ φ 38) [kg·cm ²]		
			Maximum radial load [N]	Maximum axial load [N]	Weight [kg]						
120B	2	3	4300	3900	10.2	-	6.74	8.34	15.41		
		4	4300	3900		-	5.49	7.08	14.15		
		5	4300	3900		-	5.02	6.61	13.69		
		6	4300	3900		-	4.77	6.36	13.43		
		7	4300	3900		-	4.65	6.24	13.31		
		8	4300	3900		-	4.55	6.14	13.22		
		9	4300	3900		-	4.49	6.08	13.16		
		10	4300	3900		-	4.46	6.05	13.12		
		3	15	4300		3900	10.0	2.25	2.58	4.70	-
			16	4300		3900		2.46	2.79	4.91	-
	20		4300	3900	2.20	2.53		4.65	-		
	25		4300	3900	2.18	2.51		4.64	-		
	28		4300	3900	2.40	2.73		4.86	-		
	30		4300	3900	1.87	2.20		4.33	-		
	35		4300	3900	2.16	2.49		4.62	-		
	40		4300	3900	1.86	2.19		4.32	-		
	45		4300	3900	2.15	2.48		4.61	-		
	50		4300	3900	1.86	2.19		4.31	-		
	60	4300	3900	1.85	2.18	4.31	-				
	70	4300	3900	1.85	2.18	4.31	-				
80	4300	3900	1.85	2.18	4.31	-					
90	4300	3900	1.85	2.18	4.31	-					
100	4300	3900	1.85	2.18	4.31	-					

- ※ 1 With nominal input speed, service life is 20,000 hours.
- ※ 2 The maximum torque when starting and stopping.
- ※ 3 The maximum torque when it receives shock (up to 1,000 times)
- ※ 4 The maximum average input speed.
- ※ 5 The maximum momentary input speed.
- ※ 6 With this load and nominal input speed, service life will be 20,000 hours.
(Applied to the output shaft center, at axial load 0)
- ※ 7 With this load and nominal input speed, service life will be 20,000 hours.
(Applied to the output side bearing, at radial load 0)
- ※ 8 The maximum radial load the reducer can accept.
- ※ 9 The maximum axial load the reducer can accept.
- ※ 10 The weight may vary slightly model to model

ABLE REDUCER

EVL-155B

Frame size	Stage	Ratio	※1	※2	※3	※4	※5	※6	※7
			Nominal output torque [Nm]	Maximum output torque [Nm]	Emergency stop torque [Nm]	Nominal input speed [rpm]	Maximum input speed [rpm]	Permitted radial load [N]	Permitted axial load [N]
155B	2	3	130	260	700	2000	4000	3200	2400
		4	170	340	950	2000	4000	3500	2700
		5	200	400	1100	2000	4000	3800	3000
		6	260	520	1100	2000	4000	4000	3300
		7	300	600	1100	2000	4000	4200	3500
		8	300	600	1100	2000	4000	4400	3700
		9	200	400	750	2000	4000	4600	3900
	3	10	200	400	750	2000	4000	4700	4100
		15	200	400	750	2000	4000	5400	4900
		16	300	600	1100	2000	4000	5500	5000
		20	300	600	1100	2000	4000	6000	5500
		25	300	600	1100	2000	4000	6400	6100
		28	300	600	1100	2000	4000	6700	6400
		30	200	400	750	2000	4000	6800	6600
		35	300	600	1100	2000	4000	7200	7000
		40	300	600	1100	2000	4000	7500	7500
		45	200	400	750	2000	4000	7800	7900
		50	300	600	1100	2000	4000	8100	8200
		60	300	600	1100	2000	4000	8600	8200
		70	300	600	1100	2000	4000	9100	8200
80	300	600	1100	2000	4000	9100	8200		
90	200	400	750	2000	4000	9100	8200		
100	200	400	750	2000	4000	9100	8200		

Frame size	Stage	Ratio	※8	※9	Weight [kg]	※10	※10	※10	※10
			Maximum radial load [N]	Maximum axial load [N]		Moment of inertia ($\leq \phi 19$) [kg·cm ²]	Moment of inertia ($\leq \phi 28$) [kg·cm ²]	Moment of inertia ($\leq \phi 38$) [kg·cm ²]	Moment of inertia ($\leq \phi 48$) [kg·cm ²]
155B	2	3	9100	8200	19.8	-	23.13	27.50	40.73
		4	9100	8200		-	18.57	22.94	36.17
		5	9100	8200		-	16.91	21.28	34.51
		6	9100	8200		-	16.01	20.38	33.61
		7	9100	8200		-	15.58	19.95	33.18
		8	9100	8200		-	15.23	19.61	32.84
		9	9100	8200		-	14.77	19.41	32.37
	3	10	9100	8200	-	14.66	19.03	32.26	
		15	9100	8200	20.4	6.40	8.00	15.07	-
		16	9100	8200		7.29	8.88	15.96	-
		20	9100	8200		6.22	7.81	14.89	-
		25	9100	8200		6.15	7.75	14.82	-
		28	9100	8200		7.09	8.68	15.76	-
		30	9100	8200		4.99	6.58	13.66	-
		35	9100	8200		6.09	7.69	14.76	-
		40	9100	8200		4.95	6.54	13.61	-
		45	9100	8200		6.07	7.66	14.74	-
		50	9100	8200		4.93	6.52	13.59	-
		60	9100	8200		4.92	6.51	13.59	-
		70	9100	8200		4.91	6.51	13.58	-
80	9100	8200	4.91	6.50		13.58	-		
90	9100	8200	4.91	6.50	13.57	-			
100	9100	8200	4.91	6.50	13.57	-			

- ※ 1 With nominal input speed, service life is 20,000 hours.
- ※ 2 The maximum torque when starting and stopping.
- ※ 3 The maximum torque when it receives shock (up to 1,000 times)
- ※ 4 The maximum average input speed.
- ※ 5 The maximum momentary input speed.
- ※ 6 With this load and nominal input speed, service life will be 20,000 hours.
(Applied to the output shaft center, at axial load 0)
- ※ 7 With this load and nominal input speed, service life will be 20,000 hours.
(Applied to the output side bearing, at radial load 0)
- ※ 8 The maximum radial load the reducer can accept.
- ※ 9 The maximum axial load the reducer can accept.
- ※ 10 The weight may vary slightly model to model

EVL-070B 2stage

Input shaft bore $\leq \phi 8$

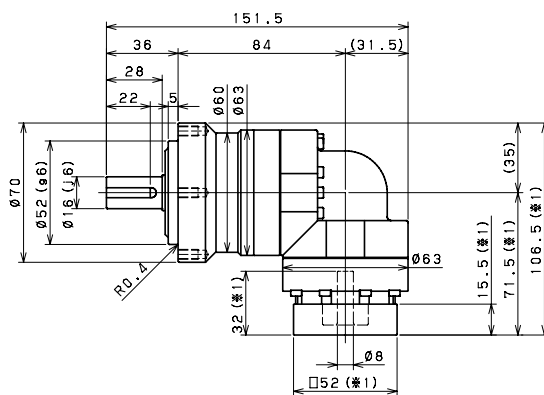
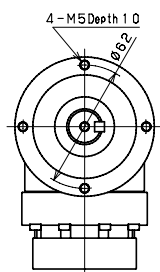

Input shaft bore $\leq \phi 14$

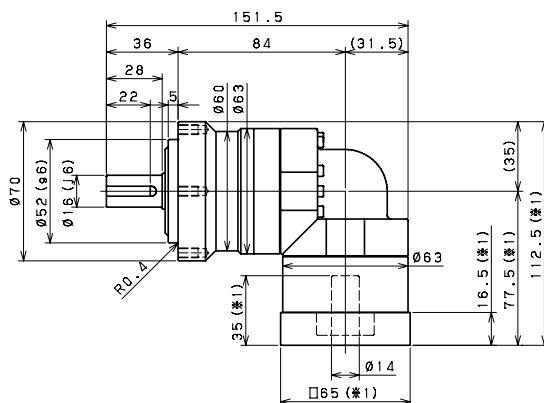
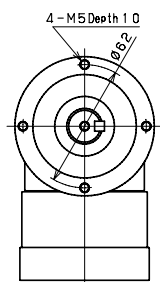

Input shaft bore $\leq \phi 8$

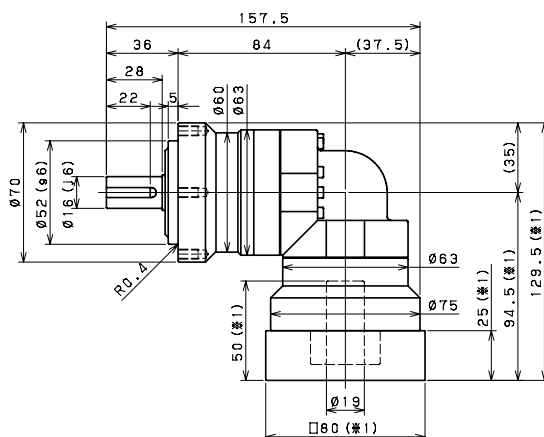
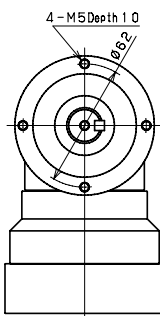

M5 Depth 1 2.5

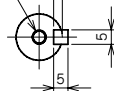

Shaft with key

M5 Depth 1 2.5



Smooth shaft

※1 Length will vary depending on motor.

※2 Bushing will be inserted to adapt to motor shaft.

EVL-070B 3stage

Input shaft bore $\leq \phi 8$

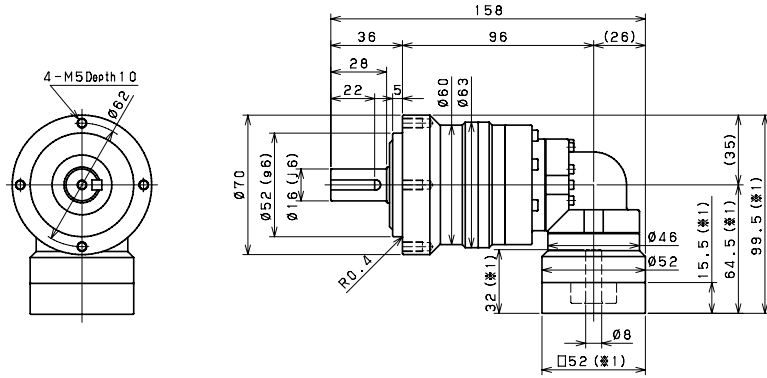

Input shaft bore $\leq \phi 14$

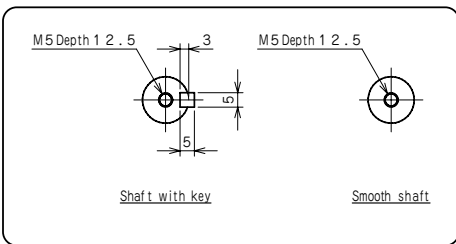
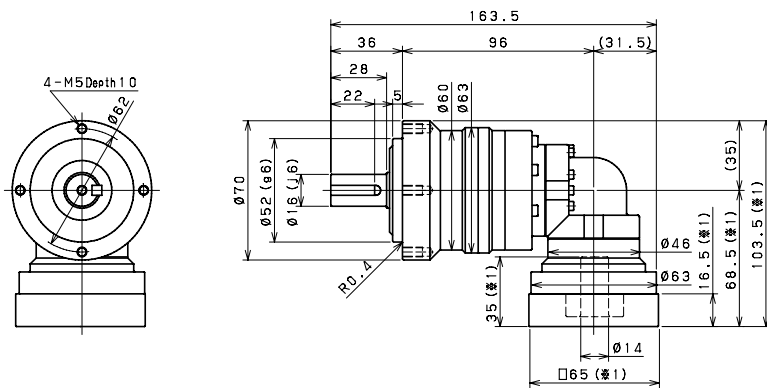

- ※ 1 Length will vary depending on motor.
- ※ 2 Bushing will be inserted to adapt to motor shaft.

EVL-090B 2stage

Input shaft bore $\leq \phi 14$

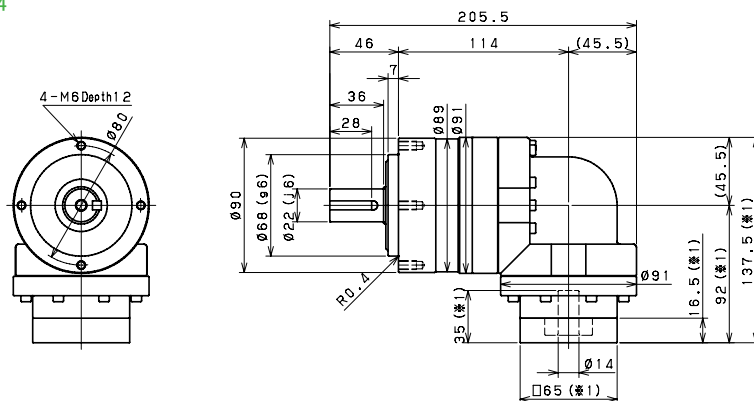

Input shaft bore $\leq \phi 19$

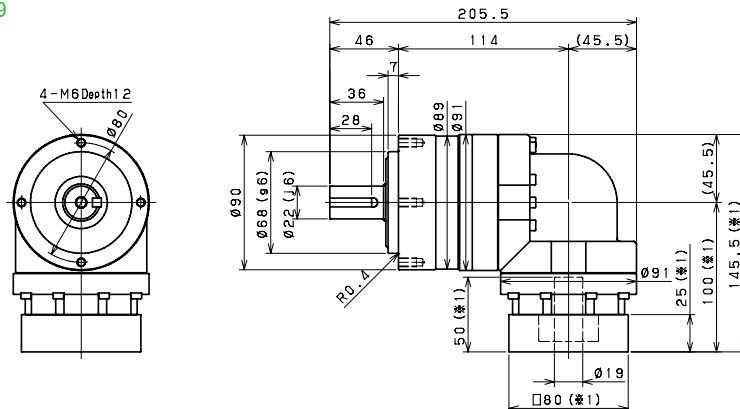

Input shaft bore $\leq \phi 28$

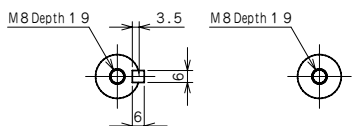
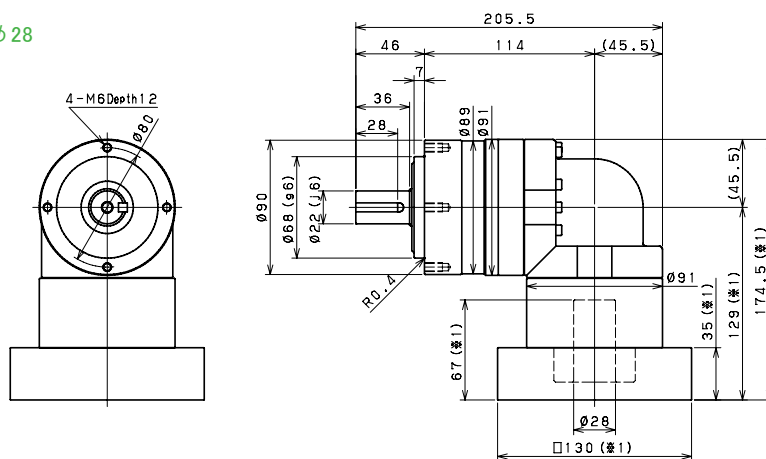

Shaft with key

Smooth shaft

※ 1 Length will vary depending on motor.

※ 2 Bushing will be inserted to adapt to motor shaft.

EVL-090B 3stage

Input shaft bore $\leq \phi 8$

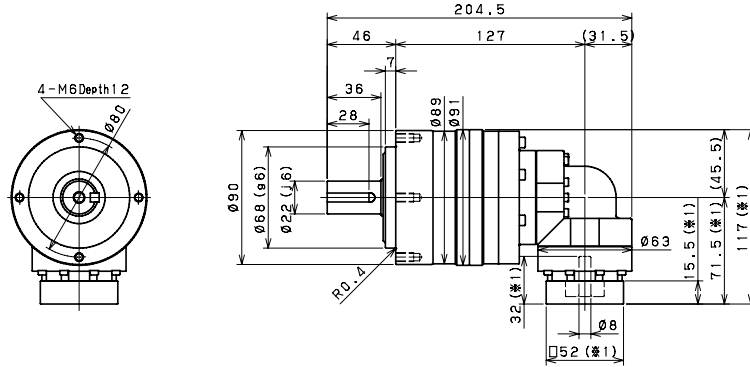

Input shaft bore $\leq \phi 14$

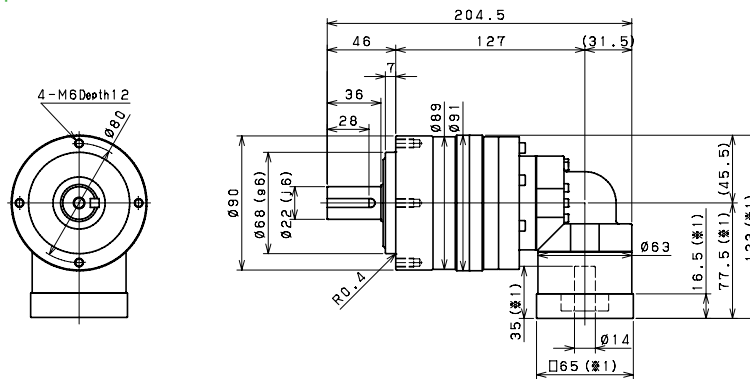

Input shaft bore $\leq \phi 19$

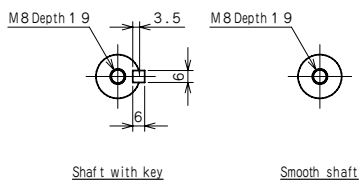
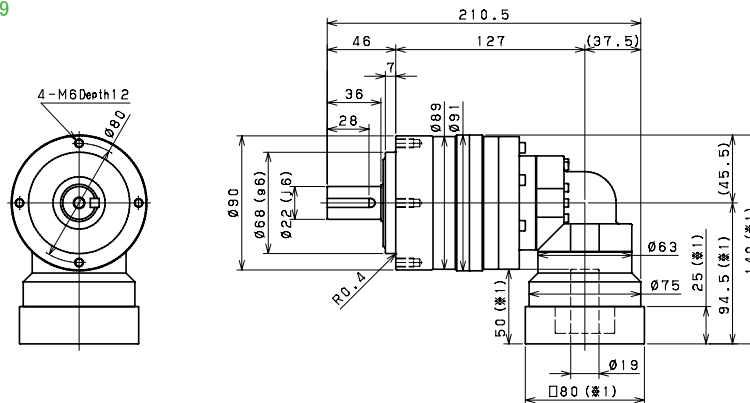

- ※1 Length will vary depending on motor.
- ※2 Bushing will be inserted to adapt to motor shaft.

EVL-120B 2stage

Input shaft bore $\leq \phi 19$

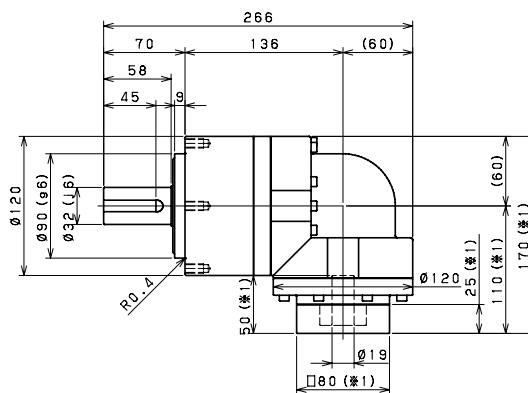
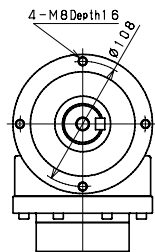

Input shaft bore $\leq \phi 28$

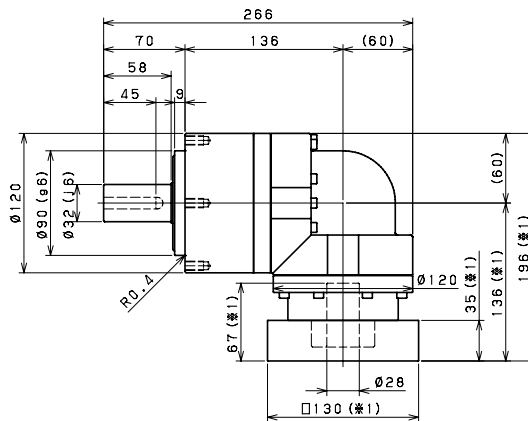
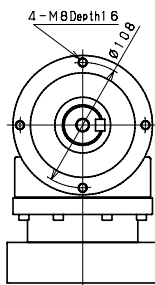

Input shaft bore $\leq \phi 38$

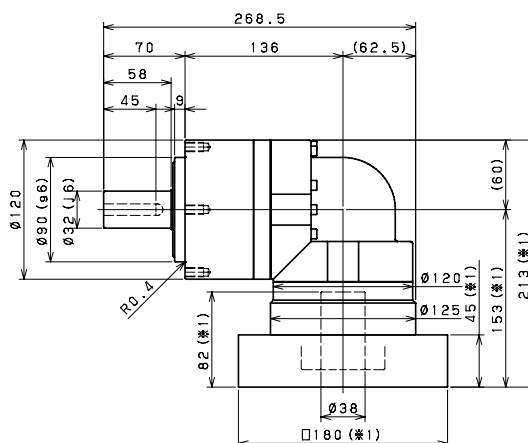
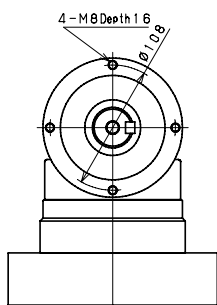

M1.2Depth 2.8

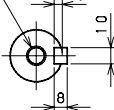

Shaft with key

M1.2Depth 2.8



Smooth shaft

※ 1 Length will vary depending on motor.

※ 2 Bushing will be inserted to adapt to motor shaft.

EVL-120B 3stage

Input shaft bore $\leq \phi 14$

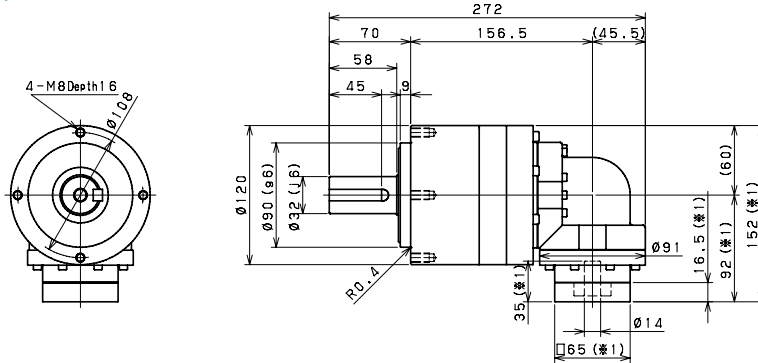

Input shaft bore $\leq \phi 19$

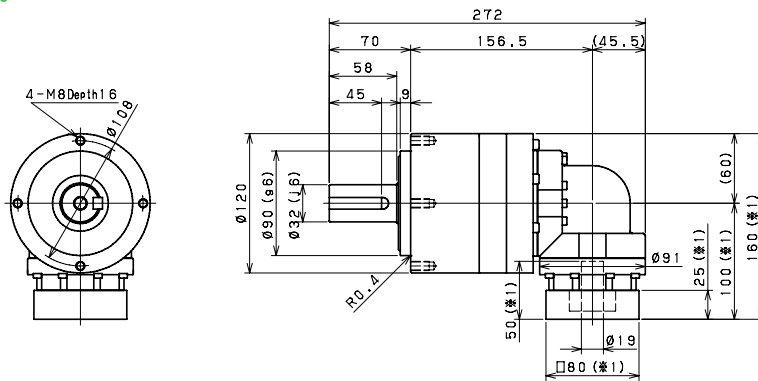

Input shaft bore $\leq \phi 28$

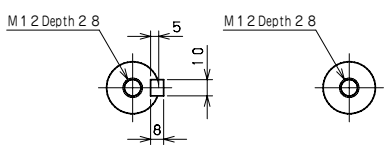
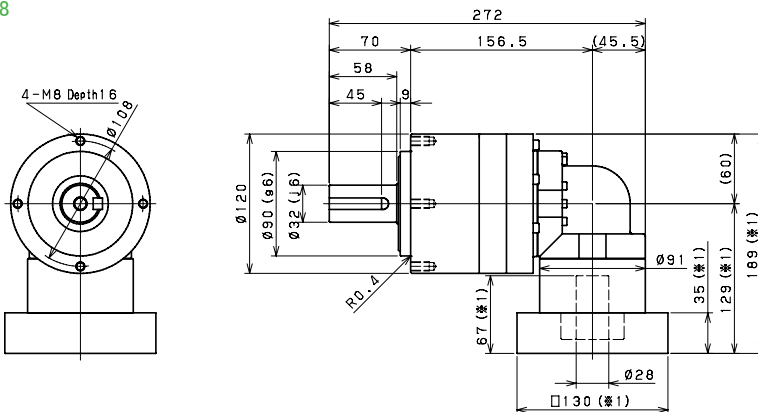

Shaft with key

Smooth shaft

- ※ 1 Length will vary depending on motor.
- ※ 2 Bushing will be inserted to adapt to motor shaft.

EVL-155B 2stage

Input shaft bore $\leq \phi 28$

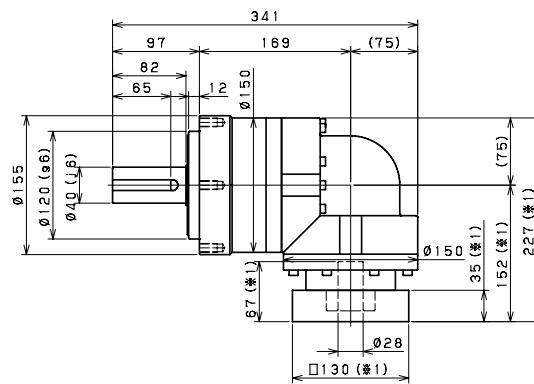
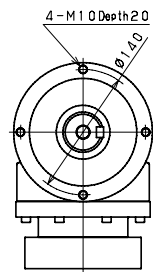

Input shaft bore $\leq \phi 38$

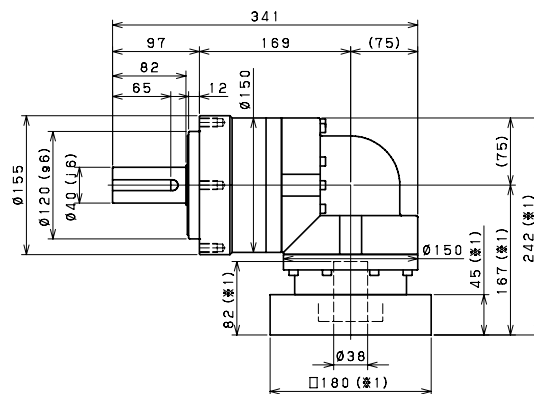
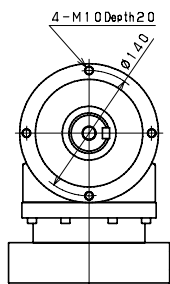

Input shaft bore $\leq \phi 48$

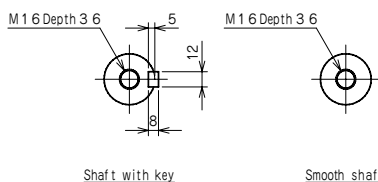
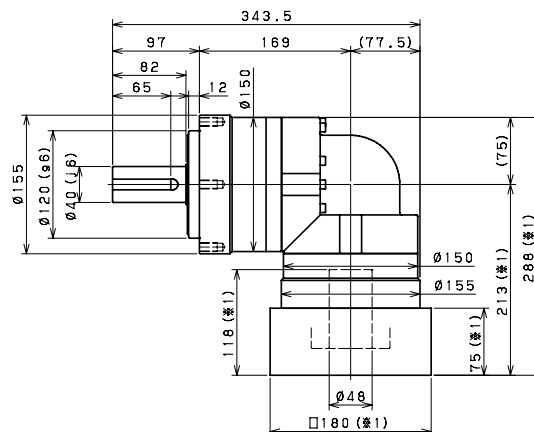
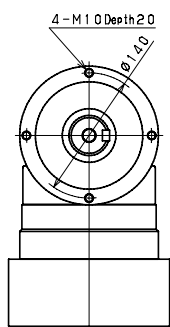

- ※ 1 Length will vary depending on motor.
- ※ 2 Bushing will be inserted to adapt to motor shaft.

EVL-155B 3stage

Input shaft bore $\leq \phi 19$

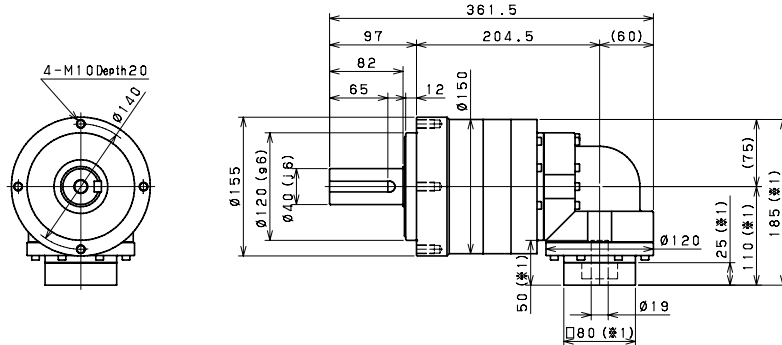

Input shaft bore $\leq \phi 28$

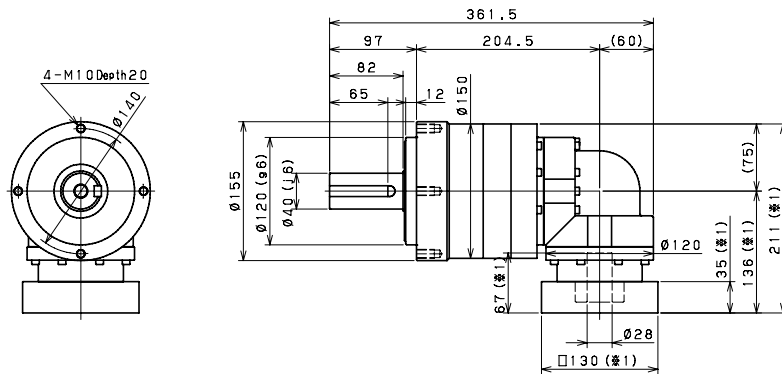

Input shaft bore $\leq \phi 38$

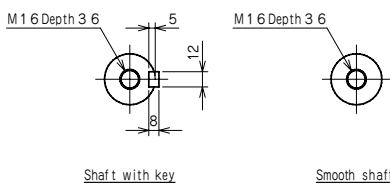
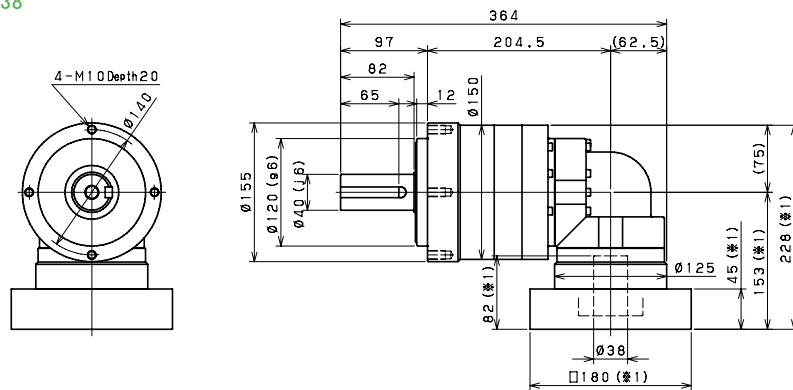

- ※ 1 Length will vary depending on motor.
- ※ 2 Bushing will be inserted to adapt to motor shaft.

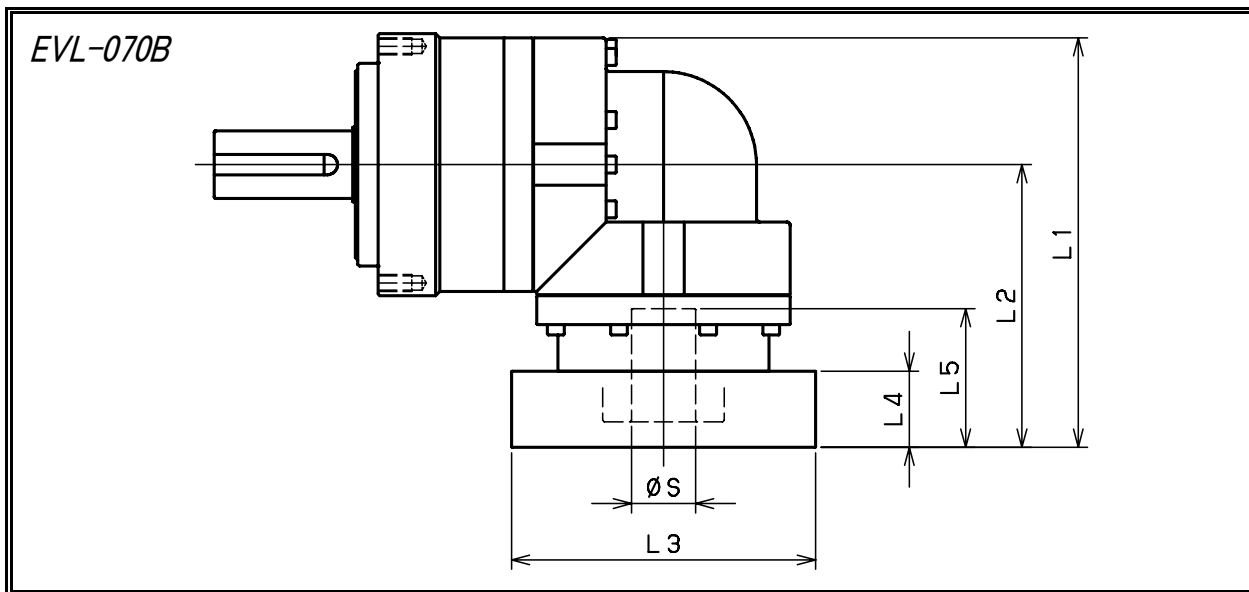

Model number	**: Adapter code	Single					Double				
		L1	L2	L3	L4	L5	L1	L2	L3	L4	L5
EVL-070B-□-□-8** (S ≤ 8)	AA·AC·AD·AF·AG	106.5	71.5	□52	15.5	32	99.5	64.5	□52	15.5	32
	AB·AE·AH·AJ·AK	111.5	76.5	□52	20.5	37	104.5	69.5	□52	20.5	37
	BA·BB·BD·BE	106.5	71.5	□60	15.5	32	99.5	64.5	□60	15.5	32
	BC·BF	111.5	76.5	□60	20.5	37	104.5	69.5	□60	20.5	37
	CA	111.5	76.5	□70	20.5	37	104.5	69.5	□70	20.5	37
EVL-070B-□-□-14** (8 < S ≤ 14)	BA·BB·BD·BE·BF·BG·BJ·BK	112.5	77.5	□65	16.5	35	103.5	68.5	□65	16.5	35
	BC·BH	117.5	82.5	□65	21.5	40	108.5	73.5	□65	21.5	40
	BL	122.5	87.5	□65	26.5	45	113.5	78.5	□65	26.5	45
	CA	112.5	77.5	□70	16.5	35	103.5	68.5	□70	16.5	35
	CB	117.5	82.5	□70	21.5	40	108.5	73.5	□70	21.5	40
	DA·DB·DC·DD·DF·DH	112.5	77.5	□80	16.5	35	103.5	68.5	□80	16.5	35
	DE	117.5	82.5	□80	21.5	40	108.5	73.5	□80	21.5	40
	DG	122.5	87.5	□80	26.5	45	113.5	78.5	□80	26.5	45
	EA·EB·EC	112.5	77.5	□90	16.5	35	103.5	68.5	□90	16.5	35
	ED	122.5	87.5	□90	26.5	45	113.5	78.5	□90	26.5	45
	FA	112.5	77.5	□100	16.5	35	103.5	68.5	□100	16.5	35
GA	112.5	77.5	□115	16.5	35	103.5	68.5	□115	16.5	35	
EVL-070B-□-□-19** (14 < S ≤ 19)	DA·DB·DC	129.5	94.5	□80	25	50					
	DD	139.5	104.5	□80	35	60					
	DE	134.5	99.5	□80	30	55					
	EA	134.5	99.5	□90	30	55					
	EB	129.5	94.5	□90	25	50					
	EC	139.5	104.5	□90	35	60					
	FA	129.5	94.5	□100	25	50					
	FB	139.5	104.5	□100	35	60					
	GA·GC	134.5	99.5	□115	30	55					
	GB·GD	129.5	94.5	□115	25	50					
	HA	129.5	94.5	□130	25	50					
	HB	144.5	109.5	□130	40	65					
	HC·HD·HE	134.5	99.5	□130	30	55					

※ 1 Single reduction : 1/3 ~ 1/10, Double reduction : 1/15 ~ 1/100

※ 2 Bushing will be inserted to adapt to motor shaft.

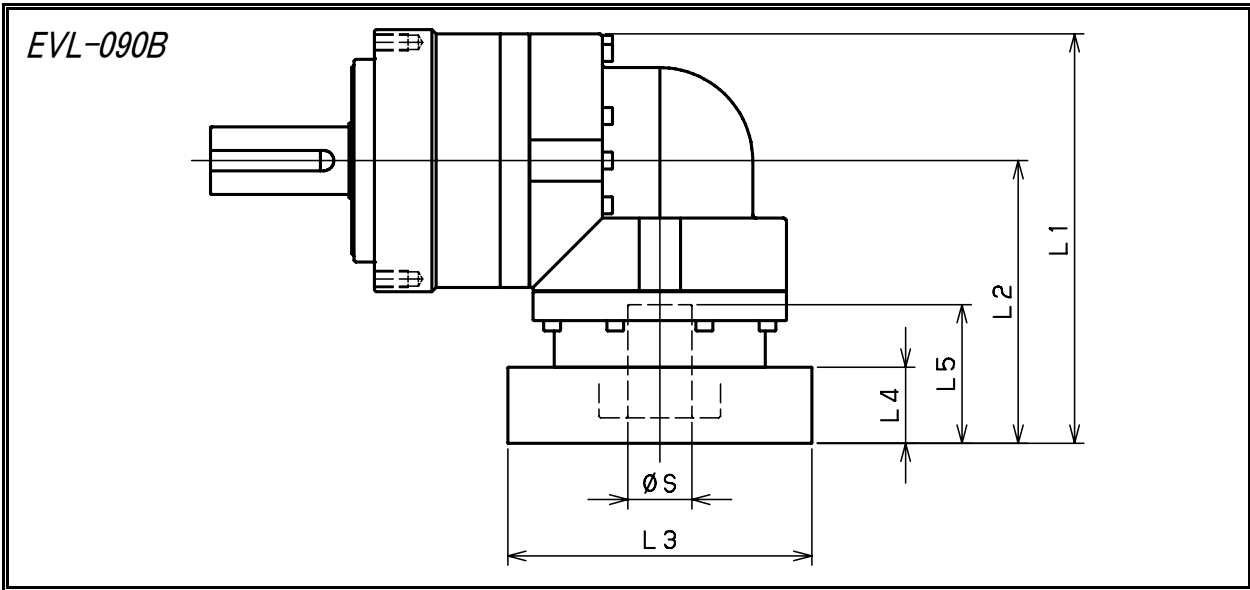

Model number	** : Adapter code	Single					Double				
		L1	L2	L3	L4	L5	L1	L2	L3	L4	L5
EVL-090B-□-□-8** (S ≤ 8)	AA·AC·AD·AF·AG	/	/	/	/	/	117	71.5	□52	15.5	32
	AB·AE·AH·AJ·AK	/	/	/	/	/	122	76.5	□52	20.5	37
	BA·BB·BD·BE	/	/	/	/	/	117	71.5	□60	15.5	32
	BC·BF	/	/	/	/	/	122	76.5	□60	20.5	37
	CA	/	/	/	/	/	122	76.5	□70	20.5	37
EVL-090B-□-□-14** (8 < S ≤ 14)	BA·BB·BD·BE·BF·BG·BJ·BK	137.5	92	□65	16.5	35	123	77.5	□65	16.5	35
	BC·BH	142.5	97	□65	21.5	40	128	82.5	□65	21.5	40
	BL	147.5	102	□65	26.5	45	133	87.5	□65	26.5	45
	CA	137.5	92	□70	16.5	35	123	77.5	□70	16.5	35
	CB	142.5	97	□70	21.5	40	128	82.5	□70	21.5	40
	DA·DB·DC·DD·DF·DH	137.5	92	□80	16.5	35	123	77.5	□80	16.5	35
	DE	142.5	97	□80	21.5	40	128	82.5	□80	21.5	40
	DG	147.5	102	□80	26.5	45	133	87.5	□80	26.5	45
	EA·EB·EC	137.5	92	□90	16.5	35	123	77.5	□90	16.5	35
	ED	147.5	102	□90	26.5	45	133	87.5	□90	26.5	45
	FA	137.5	92	□100	16.5	35	123	77.5	□100	16.5	35
GA	137.5	92	□115	16.5	35	123	77.5	□115	16.5	35	
EVL-090B-□-□-19** (14 < S ≤ 19)	DA·DB·DC	145.5	100	□80	25	50	140	94.5	□80	25	50
	DD	155.5	110	□80	35	60	150	104.5	□80	35	60
	DE	150.5	105	□80	30	55	145	99.5	□80	30	55
	EA	150.5	105	□90	30	55	145	99.5	□90	30	55
	EB	145.5	100	□90	25	50	140	94.5	□90	25	50
	EC	155.5	110	□90	35	60	150	104.5	□90	35	60
	FA	145.5	100	□100	25	50	140	94.5	□100	25	50
	FB	155.5	110	□100	35	60	150	104.5	□100	35	60
	GA·GC	150.5	105	□115	30	55	145	99.5	□115	30	55
	GB·GD	145.5	100	□115	25	50	140	94.5	□115	25	50
	HA	145.5	100	□130	25	50	140	94.5	□130	25	50
HB	160.5	115	□130	40	65	155	109.5	□130	40	65	
HC·HD·HE	150.5	105	□130	30	55	145	99.5	□130	30	55	
EVL-090B-□-□-28** (19 < S ≤ 28)	FA·FB·FC	174.5	129	□100	35	67	/	/	/	/	/
	GA·GB·GC·GD·GE·GF·GG	174.5	129	□115	35	67	/	/	/	/	/
	HA·HC·HD	174.5	129	□130	35	67	/	/	/	/	/
	HB	184.5	139	□130	45	77	/	/	/	/	/
	JA·JB·JC	174.5	129	□150	35	67	/	/	/	/	/
	KA·KB	174.5	129	□180	35	67	/	/	/	/	/
	LA	174.5	129	□200	35	67	/	/	/	/	/
MA	174.5	129	□220	35	67	/	/	/	/	/	

※ 1 Single reduction : 1/3 ~ 1/10, Double reduction : 1/15 ~ 1/100

※ 2 Bushing will be inserted to adapt to motor shaft.

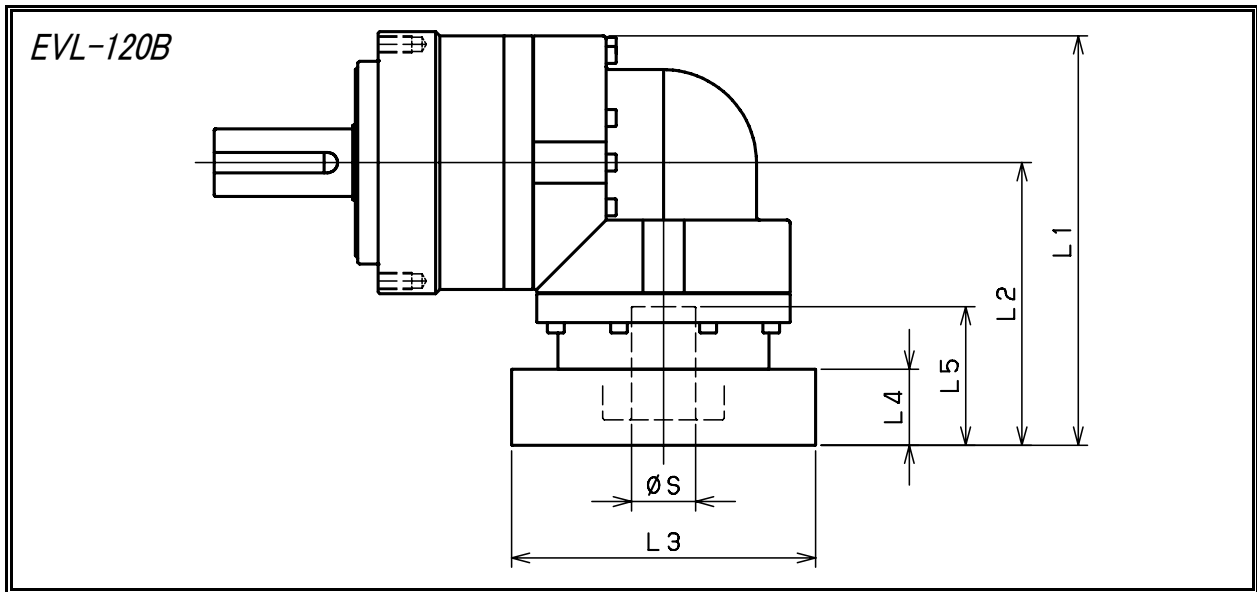

Model number	**: Adapter code	Single					Double				
		L1	L2	L3	L4	L5	L1	L2	L3	L4	L5
EVL-120B-□-□-14** (S ≤ 14)	BA·BB·BD·BE·BF·BG·BJ·BK	/	/	/	/	/	152	92	□65	16.5	35
	BC·BH	/	/	/	/	/	157	97	□65	21.5	40
	BL	/	/	/	/	/	162	102	□65	26.5	45
	CA	/	/	/	/	/	152	92	□70	16.5	35
	CB	/	/	/	/	/	157	97	□70	21.5	40
	DA·DB·DC·DD·DF·DH	/	/	/	/	/	152	92	□80	16.5	35
	DE	/	/	/	/	/	157	97	□80	21.5	40
	DG	/	/	/	/	/	162	102	□80	26.5	45
	EA·EB·EC	/	/	/	/	/	152	92	□90	16.5	35
	ED	/	/	/	/	/	162	102	□90	26.5	45
FA	/	/	/	/	/	152	92	□100	16.5	35	
GA	/	/	/	/	/	152	92	□115	16.5	35	
EVL-120B-□-□-19** (14 < S ≤ 19)	DA·DB·DC	170	110	□80	25	50	160	100	□80	25	50
	DD	180	120	□80	35	60	170	110	□80	35	60
	DE	175	115	□80	30	55	165	105	□80	30	55
	EA	175	115	□90	30	55	165	105	□90	30	55
	EB	170	110	□90	25	50	160	100	□90	25	50
	EC	180	120	□90	35	60	170	110	□90	35	60
	FA	170	110	□100	25	50	160	100	□100	25	50
	FB	180	120	□100	35	60	170	110	□100	35	60
	GA·GC	175	115	□115	30	55	165	105	□115	30	55
	GB·GD	170	110	□115	25	50	160	100	□115	25	50
HA	170	110	□130	25	50	160	100	□130	25	50	
HB	185	125	□130	40	65	175	115	□130	40	65	
HC·HD·HE	175	115	□130	30	55	165	105	□130	30	55	
EVL-120B-□-□-28** (19 < S ≤ 28)	FA·FB·FC	196	136	□100	35	67	189	129	□100	35	67
	GA·GB·GC·GD·GE·GF·GG	196	136	□115	35	67	189	129	□115	35	67
	HA·HC·HD	196	136	□130	35	67	189	129	□130	35	67
	HB	206	146	□130	45	77	199	139	□130	45	77
	JA·JB·JC	196	136	□150	35	67	189	129	□150	35	67
	KA·KB	196	136	□180	35	67	189	129	□180	35	67
	LA	196	136	□200	35	67	189	129	□200	35	67
MA	196	136	□220	35	67	189	129	□220	35	67	
EVL-120B-□-□-38** (28 < S ≤ 38)	HA	213	153	□130	45	82	/	/	/	/	/
	HB	208	148	□130	40	77	/	/	/	/	/
	JA	213	153	□150	45	82	/	/	/	/	/
	KA·KB·KC	213	153	□180	45	82	/	/	/	/	/
	LA	213	153	□200	45	82	/	/	/	/	/
	LB	223	163	□200	55	92	/	/	/	/	/
	MA·MB	213	153	□220	45	82	/	/	/	/	/
NA	213	153	□250	45	82	/	/	/	/	/	

※1 Single reduction : 1/3 ~ 1/10, Double reduction : 1/15 ~ 1/100

※2 Bushing will be inserted to adapt to motor shaft.

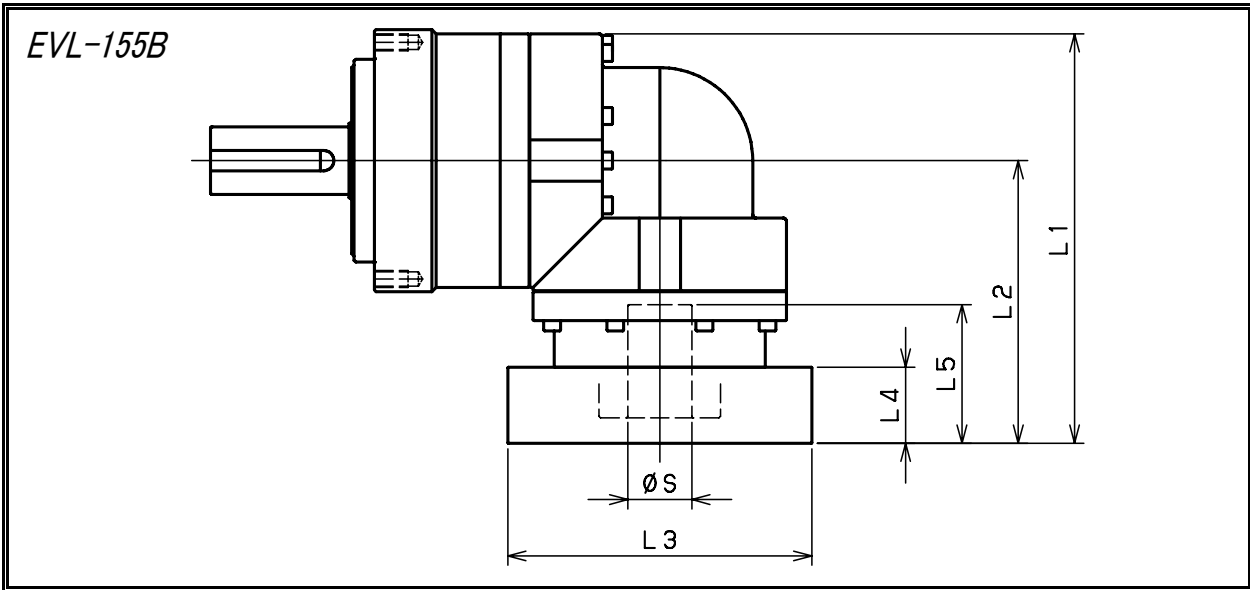

Model number	** : Adapter code	Single					Double				
		L1	L2	L3	L4	L5	L1	L2	L3	L4	L5
EVL-155B-□-□-19** (S ≤ 19)	DA·DB·DC	/	/	/	/	/	187.5	110	□80	25	50
	DD	/	/	/	/	/	197.5	120	□80	35	60
	DE	/	/	/	/	/	192.5	115	□80	30	55
	EA	/	/	/	/	/	192.5	115	□90	30	55
	EB	/	/	/	/	/	187.5	110	□90	25	50
	EC	/	/	/	/	/	197.5	120	□90	35	60
	FA	/	/	/	/	/	187.5	110	□100	25	50
	FB	/	/	/	/	/	197.5	120	□100	35	60
	GA·GC	/	/	/	/	/	192.5	115	□115	30	55
	GB·GD	/	/	/	/	/	187.5	110	□115	25	50
	HA	/	/	/	/	/	187.5	110	□130	25	50
	HB	/	/	/	/	/	202.5	125	□130	40	65
	HC·HD·HE	/	/	/	/	/	192.5	115	□130	30	55
	EVL-155B-□-□-28** (19 < S ≤ 28)	FA·FB·FC	229.5	152	□100	35	67	213.5	136	□100	35
GA·GB·GC·GD·GE·GF·GG		229.5	152	□115	35	67	213.5	136	□115	35	67
HA·HC·HD		229.5	152	□130	35	67	213.5	136	□130	35	67
HB		239.5	162	□130	45	77	223.5	146	□130	45	77
JA·JB·JC		229.5	152	□150	35	67	213.5	136	□150	35	67
KA·KB		229.5	152	□180	35	67	213.5	136	□180	35	67
LA		229.5	152	□200	35	67	213.5	136	□200	35	67
MA	229.5	152	□220	35	67	213.5	136	□220	35	67	
EVL-155B-□-□-38** (28 < S ≤ 38)	HA	244.5	167	□130	45	82	230.5	153	□130	45	82
	HB	239.5	162	□130	40	77	225.5	148	□130	40	77
	JA	244.5	167	□150	45	82	230.5	153	□150	45	82
	KA·KB·KC	244.5	167	□180	45	82	230.5	153	□180	45	82
	LA	244.5	167	□200	45	82	230.5	153	□200	45	82
	LB	254.5	177	□200	55	92	240.5	163	□200	55	92
	MA·MB	244.5	167	□220	45	82	230.5	153	□220	45	82
NA	244.5	167	□250	45	82	230.5	153	□250	45	82	
EVL-155B-□-□-48** (38 < S ≤ 48)	KB·KC	270.5	193	□180	55	98	/	/	/	/	/
	KA	290.5	213	□180	75	118	/	/	/	/	/
	LA	270.5	193	□200	55	98	/	/	/	/	/
	MA	270.5	193	□220	55	98	/	/	/	/	/
	MB	290.5	213	□220	75	118	/	/	/	/	/
	NA	290.5	213	□250	75	118	/	/	/	/	/
PA	290.5	213	□280	75	118	/	/	/	/	/	

※ 1 Single reduction : 1/3 ~ 1/10, Double reduction : 1/15 ~ 1/100
 ※ 2 Bushing will be inserted to adapt to motor shaft.

1 Mounting procedure to the motor

1 Wipe off anti-rust agent and oil on the motor shaft.

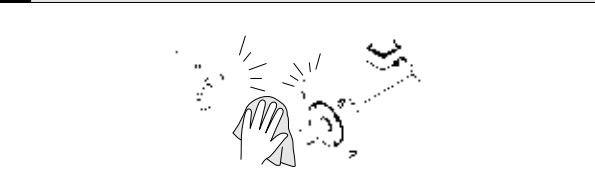

2 Remove the plug.



3 Turn the input shaft until the cap screw is seen. Make sure the cap screw is loosened.

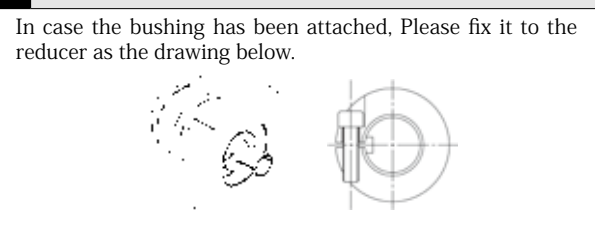

4 Please place reducer vertically on the flat surface so the motor mounting part faces up. Carefully insert the motor shaft into the input shaft. (It should be inserted smoothly) Make sure the motor flange is perfectly fit to the reducer's flange. Tighten the motor installing bolts to the proper torque. (See table1)

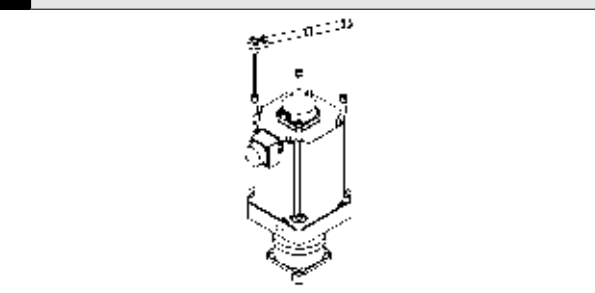

2 Reducer installation

After confirming the installation surface is flat and clean, tighten the bolt using a torque wrench to the proper torque. (See table2)

5 Tighten the clamping bolt of the input shaft with torque wrench to the proper torque. (See table1)

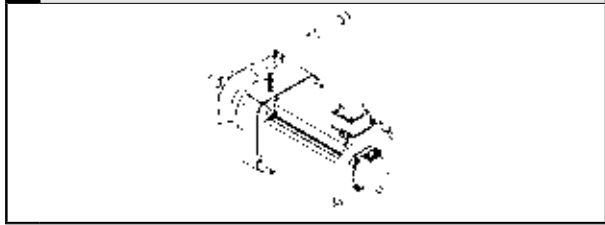

6 Reinstall the plug. The procedure is done.



Table 1

Bolt size	Motor installing bolts		Clamping bolt	
	Nm	kgfm	Nm	kgfm
M3	1.1	0.11	1.9	0.18
M4	2.5	0.26	4.3	0.44
M5	5.1	0.52	8.7	0.89
M6	8.7	0.89	15	1.5
M8	21	2.1	36	3.7
M10	42	4.3	71	7.2
M12	72	7.3	125	13
M16	134	14	-	-

Table 2

Bolt size	Tightening torque	
	Nm	kgfm
M3	1.9	0.18
M4	4.3	0.44
M5	8.7	0.89
M6	15	1.5
M8	36	3.7
M10	71	7.2
M12	125	13
M16	310	32
M20	603	62

※Recommended bolt: Strength 12.9

Servo Motor Manufacturer List

■ Japanese Servo Motor Manufacturer

Panasonic Corporation	TOSHIBA MACHINE CO.,LTD.
YASKAWA Electric Corporation	FANUC CORPORATION
Mitsubishi Electric Corporation	TAMAGAWA SEIKI CO.,LTD.
FUJI ELECTRIC CO.,LTD.	Nikki Denso
OMRON Corporation	Hitachi Industrial Equipment Systems Co.,Ltd.
SANYO DENKI CO.,LTD.	Sanmei Co.,Inc.
KEYENCE CORPORATION.	NIDEC SANKYO CORPORATION

■ Global Servo Motor Manufacturer

ALLEN BRADLEY	BECKHOFF
ABB	LENZE
B&R	LUST
BALDOR	PARKER
BAUMULLER	SAMSUNG
BOSCH REXROTH	SCHNEIDER
DELTA	SIEMENS
EMERSON (CONTROL TECHNIQUES)	TECO
ESTUN	GOLDEN AGE

* For inquiries for other servomotor manufacturer and servomotor series, please consult our subsidiary in your area.

Cautions for storage

Whenever temporarily keeping the product, keep the following directions:

- ① Keep in a clean and dry place.
- ② Whenever storing outdoors or in a humid place, put in a box so that it does not directly contact rain or external air and cover with a vinyl sheet(Take a measure to prevent rust.).

■ Cautions for operation

■ When the reducer is delivered to you . . .

When the product delivered, please confirm that you received the exact same model you have ordered.

Please wipe out the input and output shaft of the reducer which is covered by anti-corrosive oil.

※ Please remove the rubber cap on the input shaft before you wipe the shafts.

※ Lubricant(grease) is already filled in the reducer.

It is available as it is.

■ Fixation & installation

- Avoid use in a place where rain or water drops directly.
 - In case of use outdoors or in a place where dust and water drops, consult in advance.
- Install at 0°C ~40°C of surrounding temperature.
 - In case of use at temperature out of the above-mentioned range, contact the headquarters and consult on this.
- Firmly fix with a bolt onto a solid stand without vibration.
- Install in consideration of convenience in repair and inspection.

■ Cautions prior to starting the operation

- Reducer can be used soon after arrival, since it has already been filled out with lubrication.
- At initial operation, check the rotating direction of the output shaft and then gradually apply load.

■ Cautions during operation

- Avoid overload.
- Ensure that input speed shall not be the number of revolutions beyond the specification.
- In the following cases, stop the operation and check the following points:
 - If temperature sharply increases
 - If an abnormal noise appears sharply
 - If the number of revolutions becomes unstable sharply
- These may be caused by the following matters, so rapidly respond to it or contact us.
 - Is it under overload condition?
 - Is lubricant insufficient or deteriorated, or is lubricant of other type used?
 - Is the axis, gear, and motor side damaged?
 - Is jointing with other machines poor?

■ Disassembly

- ABLE REDUCER is designed not to allow disassembly.

■ Warranty

- A warranty period is one year after the product is delivered to you.

■ Lubricant use

- The ABLE REDUCER is of grease-seal type in all models.
A specified amount of grease is filled at factory release, so you can use as soon as it is delivered to you.
- It is impossible to exchange grease.
- In case of use at 0°C ~40°C of surrounding temperature at usual times, consider this in advance.

■ Daily check points

- Is reducer case temperature excessively high during operation? (Up to + 50°C is not significant.)
- Is there an abnormal noise in the bearing, gear, etc?
- Is there abnormal vibration in the reducer?
 - * Upon an abnormal phenomenon, immediately stop the operation and contact us.
- Is there a lubricant leak?
 - * Upon an oil leak, contact us.

■ Periodic check points

- Are there overload and abnormal rotation?
- Are free, sprocket, and reducer assembling bolts loose?
- Is there an abnormal condition in the electric system?
- Checkup and repair of major parts
 - ※ Upon an abnormal condition, immediately stop the operation and contact us.
- Oil leak
 - ※ Upon an oil leak, contact us.

■ Scrapping

Whenever scrapping the ABLE REDUCER, classify the parts by material into industrial wastes as specified in the laws and regulations of self-governing bodies. Material of parts can be divided into four:

- ① Rubber parts : Oil seal, seat packing, rubber cap, seal used for bearing on the motor flange, etc.
- ② Aluminum parts : Motor flange, output shaft holder
- ③ Grease : Wipe off grease attached to parts with dry cloth and scrap into oils.
- ④ Iron parts : Parts other than those mentioned in the above

WARRANTY PROVISION

- Warranty scope is the delivered product only.

■ THE EXPENSES AND LOSSES THAT MENTIONED BELOW ARE NOT INCLUDED IN WARRANTY

- 1)The transport charges for repairing of our products.
- 2)The fee for the removal operation, reinstallation and other related operation in case our product is installed to the other machine.
- 3)The loss of the chances of use and indirect damages caused by the interruption of the services caused by our product's defects.
- 4)All other secondary expenses and losses.

You can download the CAD drawings(2D · 3D) of ABLE REDUCER EVS series.

<http://www.nidec-shimpo.co.jp/en/>



Choose from [Make a selection from the motor list] and [Make a selection from load condition] .

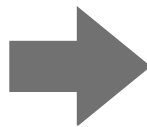

DXF, IGS, STP format data can be downloaded.

NETWORK

Bases in Japan: Tokyo branch/Nagoya branch/Kansai branch/Kita Kanto branch/
Kanazawa branch/Fukuoka branch

Tokyo branch	☎Tokyo (03) 3494-0721	Kita Kanto branch	☎Hatogaya (048) 287-1159
Nagoya branch	☎Nagoya (052) 219-6781	Kansai branch	☎Kyoto (075) 958-3670
Kanazawa branch	☎Kanazawa (076) 233-2626	Fukuoka branch	☎Fukuoka (092) 411-4750
Sales Dept.	☎Kyoto (075) 958-1298	International Sales & Marketing Dept.	☎Kyoto (075) 958-3608
Headquarters	☎Kyoto (075) 958-3606		

NIDEC Group: NIDEC Corporation/ NIDEC SANKYO Corporation/ NIDEC COPAL / NIDEC TOSOK Corporation/ NIDEC COPAL Electronics Corporation/ NIDEC Servo Corporation/ NIDEC LEAD Corporation/ NIDEC TECHNO MOTOR HOLDINGS CORPORATION/ NIDEC KYORI Corporation/ NIDEC Logistic Corporation/ NIDEC Machinery Corporation/ NIDEC Pigeon Corporation/ NIDEC Total Service Corporation/ NIDEC NISSIN Corporation



QUALITY

We are making efforts for quality improvement on the basis of the concept of total quality control.



Deming Award to be given to enterprises practicing excellent quality control

■NIDEC-SHIMPO has obtained ISO 9001/ISO 14001 certification of quality assurance.

ISO 9001

■Range of registrations

Design, development, manufacturing, and relevant service(refurbishing) of the following products:

- CVT
- Reducer
- Electronic measuring instrument(Digital revolution indicator/ Stroboscope)
- Control units(digital controller)
- Ceramic devices(motor plane/kiln)

ISO 14001

■Range of registrations

Design, development, manufacturing, and refurbishing of CVT, reducer, measuring instruments, control units, ceramic devices, and other industrial devices

- Factories:



HISTORY



A *Nidec* Group Company
SHIMPO
All for dreams

