

# Euro404 / Euro408

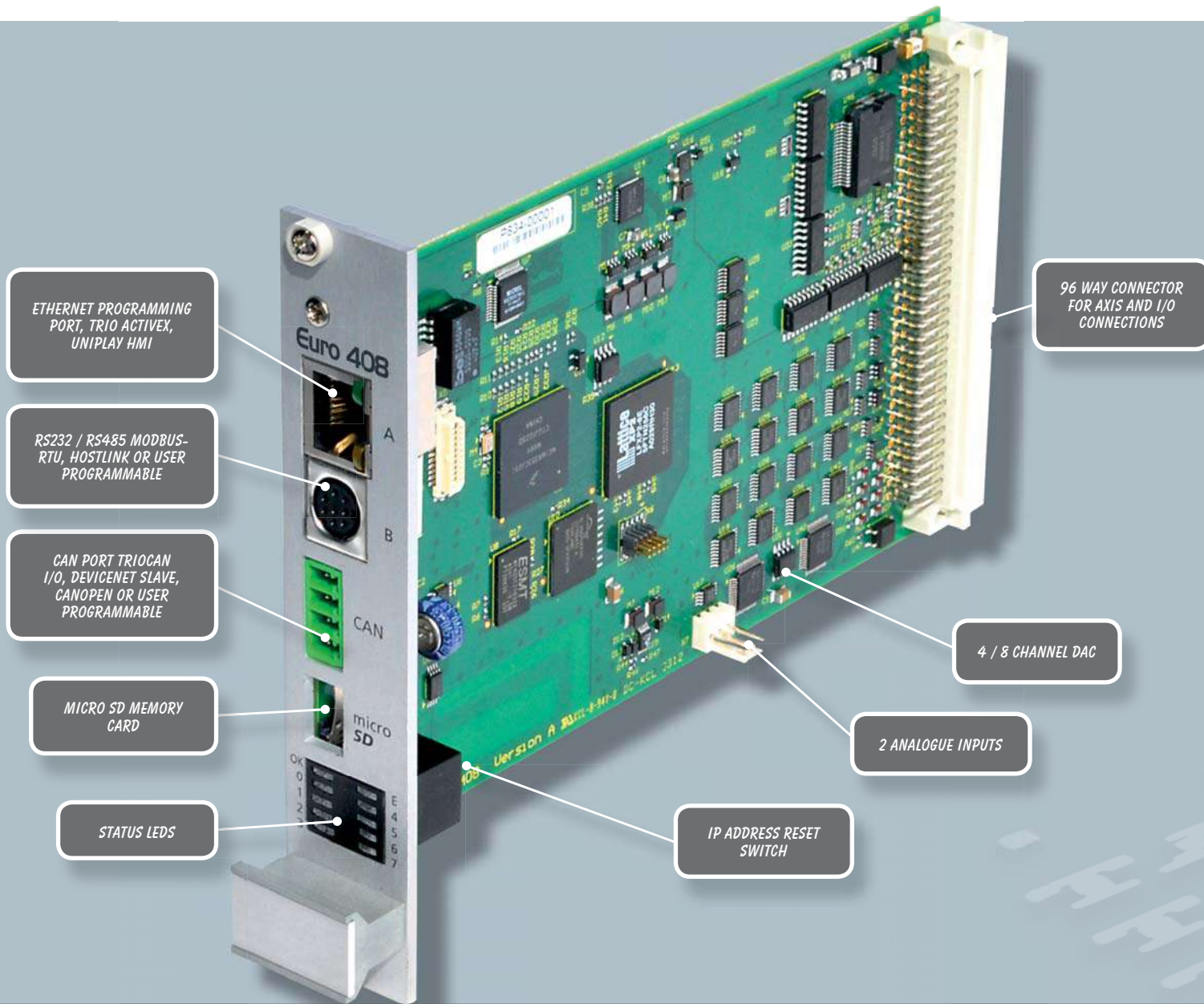

- ### FEATURES
- \* Linear, Circular, Helical and Spherical Interpolation
  - \* Flexible CAM shapes, Linked Motion
  - \* EnDAT and SSI Absolute Encoder Supported
  - \* Hardware Linked Outputs for Camera / Laser Control
  - \* Ethernet-IP / Modbus TCP / Ethernet Interface Built-In
  - \* 125 – 2000 $\mu$ sec Selectable Servo Update
  - \* Precise 64 bit Motion Calculations on ARM11 Processor with VFP
  - \* IEC 61131 Programming
  - \* Multi-tasking BASIC Programming
  - \* Text File Handling
  - \* Robotic Transformations
  - \* Micro SD Memory Card Slot
  - \* CANopen I/O Expansion
  - \* 3U Rack Mount Format
  - \* RoHS and CE Approved

The Euro404 and Euro408 *Motion Coordinators* are designed to provide a powerful yet cost effective control solution for OEM machine builders that are prepared mount the unit and provide the power supplies required.

Both the Euro404 and Euro408 are high specification *Motion Coordinators* using a high performance ARM11 processor, with up to 4 / 8 flexible axis ports and 4 / 8 voltage outputs respectively. The flexible axis ports can be configured in software as feedback devices or pulse direction outputs. As outputs they can be used as pulse and direction with stepper or servo drives or they can operate as a simulated encoder output. When configured as feedback they can be either incremental encoder input or one of three popular absolute encoder types; SSI, Tamagawa or Endat. Any feedback axis with a Voltage output can be used to form a closed loop servo.

The built-in Ethernet port allows programming and connection of common HMI and PLC protocols directly to the *Motion Coordinator*. User programs can be written in Trio's established multi-tasking TrioBASIC language using the powerful *Motion Perfect v3* application development software making complex motion easy. Also available as an option are the industry standard IEC 61131-3 languages allowing a fully functional PLC programming system.

The Euro404 / 408 are each available in 2 different axis configurations. All models feature a total of 16 axes in software. Any axes not assigned to built-in hardware can be used as a virtual axis. Every axis can be programmed to move using linear, circular or helical interpolation, electronic cams, linked axes and gearboxes.

**ACCESSORIES:**

P317 - P327	CAN Modules
P446	Euro Breakout Board
P750	Kinematic Runtime FEC
P843 - P844	UNIPLAY 7" & 10" HMI's

**OVERALL DIMENSIONS**

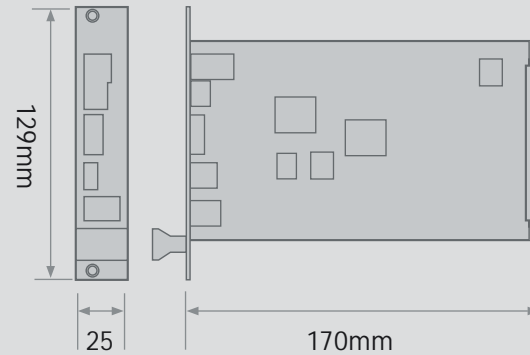

	EURO404 PRODUCT OPTIONS		EURO408 PRODUCT OPTIONS	
	P831	P832	P833	P834
Axis 0	Core	Extended + AS	Core	Extended + AS
Axis 1	Core	Extended + AS	Core	Extended + AS
Axis 2	Core	Extended + AS	Core	Extended + AS
Axis 3	Core	Extended + AS	Core	Extended + AS
Axis 4			Core	Extended + AS
Axis 5			Core	Extended + AS
Axis 6			Core	Extended + AS
Axis 7			Core	Extended + AS

**CORE AXES** – can be configured in software as pulse and direction outputs to stepper or servo drives. They can also be configured for incremental encoder feedback or simulated encoder output.

**EXTENDED AXES** – in addition to the Core functionality these axes can also be configured for SSI, Tamagawa or Endat absolute encoders.

AS -Analogue 'closed loop' Servo using built-in  $\pm 10V$  analogue output.

