

MC4N-RTEX Mini RTEX Master

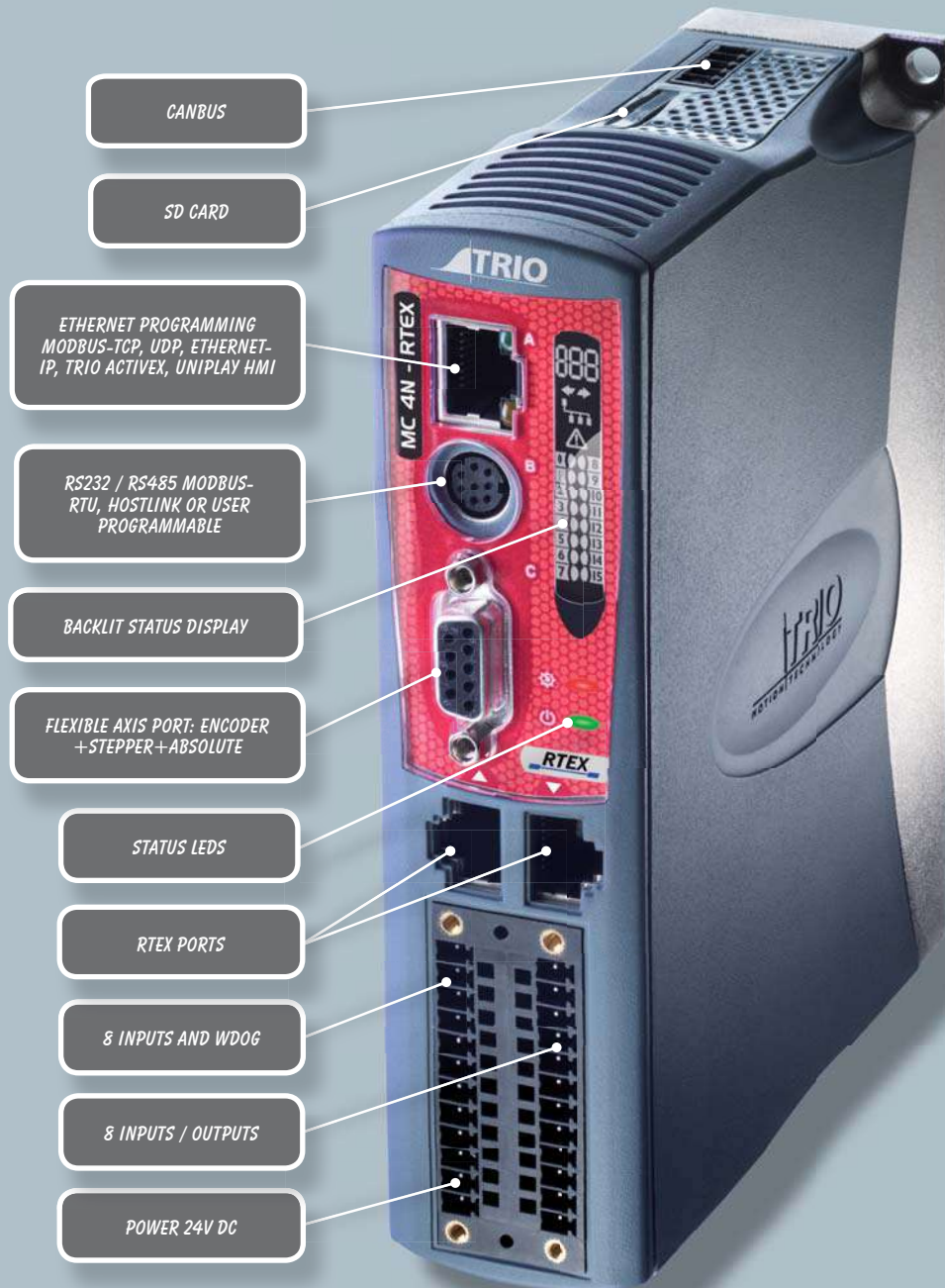

The MC4N-RTEX is dedicated to running remote servo drives via Panasonic's RTEX Real Time EXpress automation bus. It is based on an up-rated version of the 532MHz ARM 11 processor which makes it ideal for high axis count machines or robotic applications.

The MC4N-RTEX supports up to 32 axes of motion with 64 bit integer position registers for ultra precise axis resolution. RTEX slave drives and I/O can be connected and run in cyclic synchronous position, speed or torque modes. Programming the MC4N is identical to using traditional analogue axes with the addition of being able to set up drives and process alarms over the RTEX bus. With everything programmed from one place, machine control has never been so simple.

Panasonic
RTEX
 Realtime Express

FEATURES

- ★ Up to 32 RTEX Digital Drive Axes
- ★ Up to 1024 I/O
- ★ Linear, Circular, Helical and Spherical Interpolation
- ★ Flexible CAM shapes, Linked Motion
- ★ Isolated Encoder Port
- ★ EnDAT and SSI Absolute Encoder Supported
- ★ Hardware Linked Output for Camera / Laser Control
- ★ Ethernet-IP / Modbus TCP / Trio ActiveX / Uniplay HMI / UDP / Ethernet Interface Built-In
- ★ Precise 64Bit Motion Calculations with 532MHz ARM 11 Processor
- ★ IEC 61131-3 Programming
- ★ Multi-tasking BASIC Programming
- ★ Text File Handling
- ★ Robotic Transformations
- ★ 4 High Speed Registration Inputs
- ★ Isolated RS232 and RS485 ports
- ★ SD Memory Card Slot
- ★ CANopen I/O Expansion
- ★ Backlit LCD Display
- ★ RoHS and CE Approved



The built-in Ethernet port allows programming and connection of common PLC and HMI protocols, including the Trio Uniplay range of HMIs, directly to the MC4N. User programs can be written in Trio's established multi-tasking TrioBASIC language using the powerful *Motion Perfect v3* application development software making complex motion easy. The industry standard IEC 61131-3 languages are available as an option, allowing a fully functional PLC programming system.

Versions of the MC4N are available for 2, 4, 8, 16 and 32 motor axes. All versions feature 32 software axes any of which may be used as virtual axes if not assigned to RTEX hardware. Every axis can be programmed to move using linear, circular or helical or spherical interpolation, electronic cams, linked axes and gearboxes. The power of the controller allows for multiple robotic transformations to run simultaneously.

A bright easy to read backlit display enables the controller status to be easily determined, whilst the single piece metal cast backplate provides an integrated earth chassis to improve noise rejection in the industrial environment.

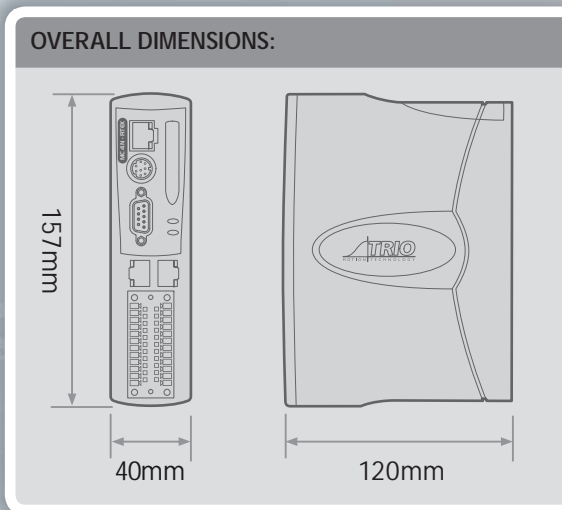

ACCESSORIES:

P317 - P327	CAN Modules
P750	Kinematic Runtime FEC
P843 - P844	UNIPLAY 7" & 10" HMI's

PRODUCT CODES:

P906	MC4N-RTEX 2 Axis
P907	MC4N-RTEX 4 Axis
P908	MC4N-RTEX 8 Axis
P909	MC4N-RTEX 16 Axis
P910	MC4N-RTEX 32 Axis

MC4N - MINI MASTER RANGE:

MC4N-ECAT	Mini EtherCAT Master
MC4N-RTEX	Mini RTEX Master

