

Safety Precautions

- Important Notes on exporting this product or equipment containing this product;
If the end-user or application of this product is related to military affairs or weapons, its export may be controlled by "Foreign Exchange and Foreign Trade Control Law" of Japan where export license will be required before product can be exported from Japan.
- This product is designed and manufactured for use in General Purpose Industrial Equipment and it is not intended to be used in equipment or system that may cause personal injury or death.
- All servicing such as installation, wiring, operation, maintenance and etc., should be performed by qualified personnel only.
- Tighten mounting screws with an adequate torque by taking into consideration strength of the screws and the characteristics of material to which the product will be mounted. Over tightening can damage the screw and/or material; under tightening can result in loosening.
- Install safety equipment to prevent serious accidents or loss that is expected in case of failure of this product.
- Consult us before using this product under such special conditions and environments as nuclear energy control, aerospace, transportation, medical equipment, various safety equipments or equipments which require a lesser air contamination.
- We have been making the best effort to ensure the highest quality of our products, however, some applications with exceptionally large external noise disturbance and static electricity, or failure in input power, wiring and components may result in unexpected action. It is highly recommended that you make a fail-safe design and secure the safety in the operative range.
- If the motor shaft is not electrically grounded, it may cause an electrolytic corrosion to the bearing, depending on the condition of the machine and its mounting environment, and may result in the bearing noise. Checking and verification by customer is required.
- Failure of this product depending on its content may generate smoke of about one cigarette. Take this into consideration when the application of the machine is clean room related.
- Please be careful when using the product in an environment with high concentrations of sulfur or sulfuric gases, as sulfuration can lead to disconnection from the chip resistor or a poor contact connection.
- Do not input a supply voltage which significantly exceeds the rated range to the power supply of this product. Failure to heed this caution may lead to damage of the internal parts, causing smoke and/or fire and other troubles.
- The user is responsible for matching between machine and components in terms of configuration, dimensions, life expectancy, characteristics, when installing the machine or changing specification of the machine. The user is also responsible for complying with applicable laws and regulations.
- Manufacturer's warranty will be invalid if the product has been used outside its stated specifications.
- Component parts are subject to minor change to improve performance.
- Read and observe the instruction manual to ensure correct use of the product.

Repair

Consult to the dealer from whom you have purchased this product for details of repair work.
When the product is incorporated to the machine you have purchased, consult to the machine manufacturer or its dealer.

URL

Electric data of this product (Instruction Manual, CAD data) can be download from the following web site;
industrial.panasonic.com/ac/e/

● Contact to : _____

Panasonic Corporation,
Industrial Device Business Division
1006, Oaza Kadoma, Kadoma-shi, Osaka 571-8506, Japan
©Panasonic Corporation 2019
The contents of this catalog apply to the products as of October 2019.

■AQCTB04E 201910

Panasonic

INDUSTRY

AC Servo Motor & Driver

Network/ Linear and Direct Drive Control

Collaboration

Network, Linear & Direct Drive Motor Control System

● This product is for industrial equipment. Don't use this product at general household.

Servo motor that brings out potential of the machine.

“Realtime Express” model

A6N series



- Com. period min. 0.0625 ms
- Standard Ethernet cable*1 using

EtherCAT communication type

A6B series



- CiA 402 protocol is available
- Standard Ethernet cable*1 using

Linear and DD motor control type

A6L series



- Position, Speed, Thrust control and Block operation
- Drastically reduced setup time by automatic setup

Ultra compact DC Servo

A5M series

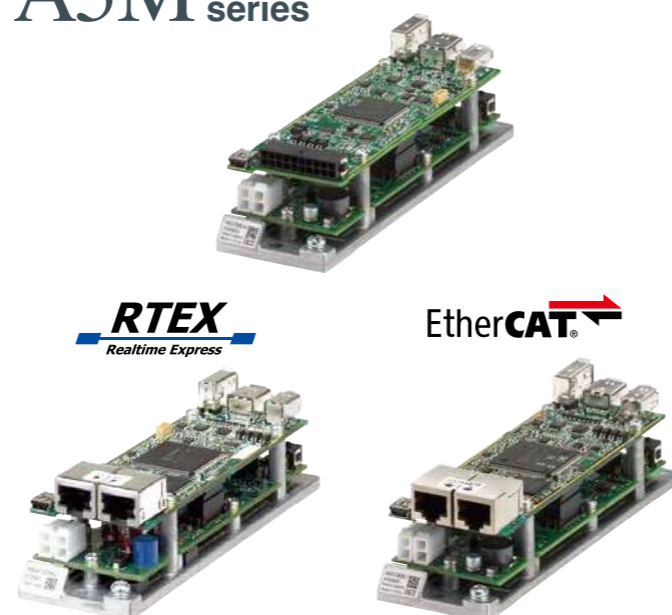

- Line-up: DC24 V/48 V and up to 30 W rotary motor and linear
- Control Line-up: Pulse train, RTEX and EtherCAT
- Applicable motor: Rotating motor/ Linear motor/ Direct drive motor

*1 Shielded twisted pair cable (CAT5e or higher)

[Partner product] (Quality of partner product is guaranteed by the manufacturer and distributor.)

RTEX

Introduction of MINAS A6N series and RTEX controller	3
ACE Automation Co., Ltd.	9
AJINEXTEK CO., LTD.	11
Asahi Engineering Co., Ltd.	13
Aurotek Corporation	15
BDF DIGITAL	17
COSMOTECHS	19
eMotionTek Co., Ltd.	23
Leadshine Technology Co., Ltd.	25
PAIX CO., LTD.	27
Prime Motion Inc.	29
Soft Servo Systems, Inc.	31
SYNTEC Technology Co., Ltd.	33
TIETECH Co., Ltd.	35
Trio Motion Technology Ltd.	39
Anywire Corporation	43
RTEX corresponding table and ASIC information	44

EtherCAT

Introduction of EtherCAT/ MINAS A6B series and EtherCAT controller	45
acontis technologies GmbH	51
ADLINK Technology, Inc.	53
Advanet Inc.	57
Advantech Co., Ltd.	59
ALGO SYSTEM Co.,Ltd.	61
Beckhoff Automation GmbH & Co. KG	63
CODESYS Group	65
CONTEC CO., LTD.	67
FAGOR AUTOMATIO	69
Galil Motion Control, Inc.	71
Hivertec, Inc.	73
Hypertherm, Inc.	75
ISAC	77
Leadshine Technology Co., Ltd.	81
Micronet Company	85
Mujin, Inc.	87
National Instruments Corporation	89
NEXCOM International Co., Ltd.	91
Soft Servo Systems, Inc.	93
TECHNO Co., Ltd.	95
Tex Computer srl	97
Trio Motion Technology Ltd.	99
EtherCAT partner products	105

LINEAR MOTOR and DIRECT DRIVE MOTOR

Introduction of MINAS A6L series	107
Akribis Systems Pte Ltd	111
ETEL	115
Justek Inc.	117
LinMot	119
Mirae Linear Motor Technology	121
Nippon Pulse Motor Co., Ltd.	123
SEWOO INDUSTRIAL SYSTEMS CO., LTD.	127
SINADRIVES	129
SINFONIA TECHNOLOGY Co.,LTD.	131
Sodick Co., Ltd.	133
Tecnotion	137
TPC Mechatronics Co., Ltd.	139

FEED BACK SCALE

FAGOR AUTOMATION	141
HEIDENHAIN	145
Magnescale Co., Ltd.	149
MITSUBISHI HEAVY INDUSTRIES MACHINE TOOL CO., LTD	153
Mitutoyo Corporation	155
Renishaw plc	157
RSF Elektronik	159
NIDEC SANKYO CORPORATION	161
Feed back scale selection	162

ACTUATOR

Harmonic Drive Systems Inc.	163
Nabtesco Corporation	167
SURUGA SEIKI CO.,LTD.	169

SYSTEM SOLUTIONS

Panasonic Corporation	171
-----------------------------	-----

Ultra High-Speed Network Servo MINAS A6N series

Manufacturer/
Distributor: Panasonic Corporation



Realtime Express (RTEX)

Ultimate Real-time performance

- Com. period min. **0.0625 ms**
- Com. speed **100 Mbps** Full-duplex
- Velocity response **3200 Hz**

Max 16000 times/s

Functionality to meet various needs

- Precise position latch & comparing
- Infinitely rotatable absolute encoder
- IEC safety I/F model available^{*1}

Simple network

- High-performance & Low-cost
- Isochronous established by ASIC
- Easy device development



[Typical system configuration]

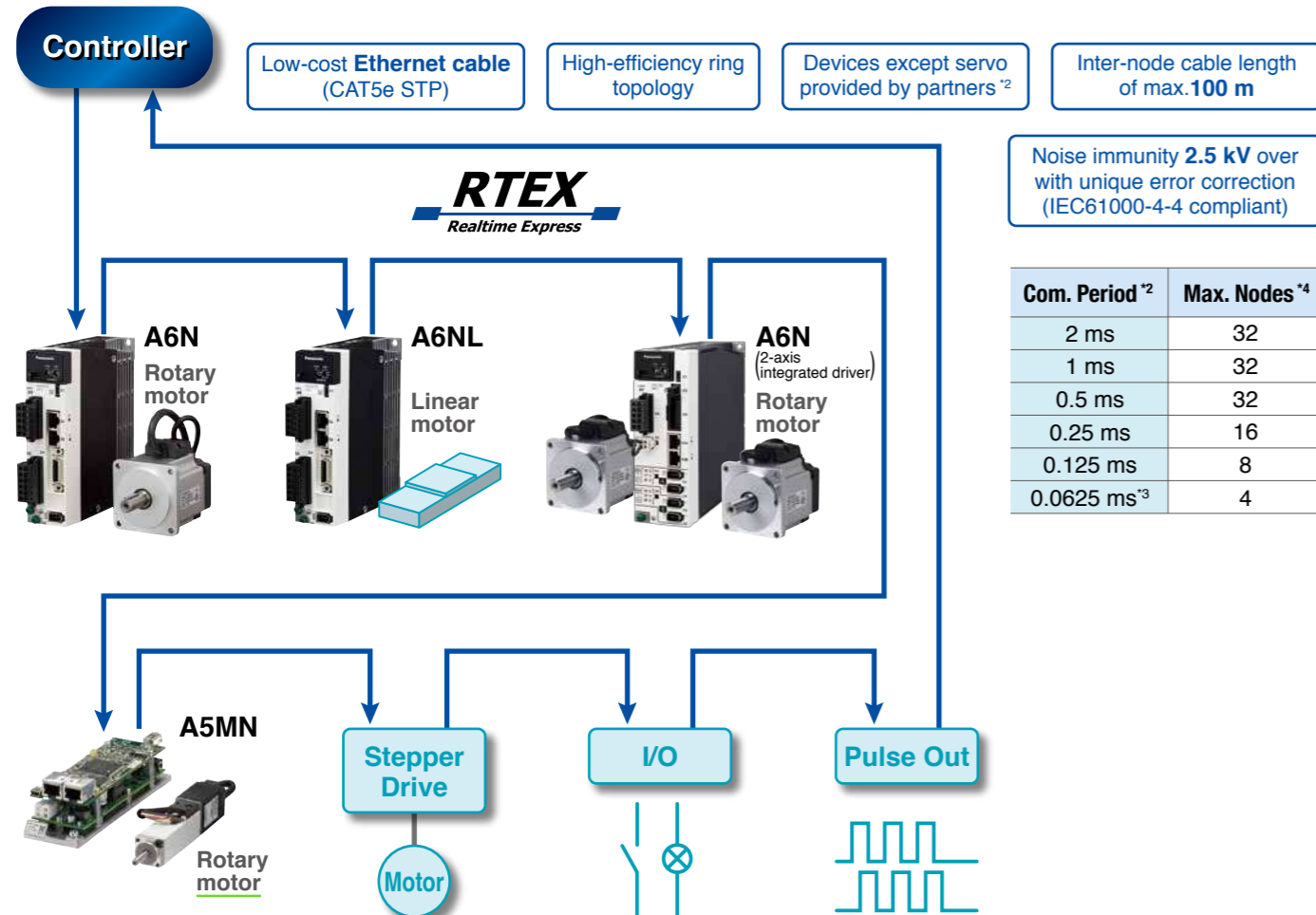

Drive list

Drive power supply	Motor rated output													
	50 W	100 W	200 W	400 W	750 W	1 kW	1.5 kW	2 kW	3 kW	4 kW to 5 kW	7.5 kW	11 kW to 15 kW	22 kW	
Single axis driver	1-phase 100 V to 120 V AC	Frame size	A	A	B	C								
		Model No.	MADLT 01NE	MADLT 11NE	MBDLT 21NE	MCDLT 31NE								
	1 or 3-phase 200 V to 240 V AC	Frame size	A		A	B	C	D	D					
		Model No.	MADLT 05NE		MADLT 15NE	MBDLT 25NE	MCDLT 35NE	MDDLTL 45NE	MDDLTL 55NE					
3-phase 200 V to 240 V AC	Frame size								E	F	F	G	H	
	Model No.								MEDLT 83NE	MFDLT A3NE	MFDLT B3NE	MGDLT C3NF	MHDLT E3NF	MHDLT F3NF
3-phase 380 V to 480 V AC	Frame size					D	D		E	F	F	G	H	
	Model No.					MDDLTL 54NF	MDDLTL 64NF		MEDLT 84NF	MFDLT A4NF	MFDLT B4NF	MGDLT C4NF	MHDLT E4NF	MHDLT F4NF
2-axis integrated driver	1 or 3-phase 200 V to 240 V AC	Model No.	← MPDLT15N△ →											
					← MPDLT 25N△ →									
3-phase 200 V to 240 V AC	Model No.													

- The above table shows a drive model number (Type E) in typical combination. (400 V specification, G frame and H frame are only multi-function type.)
- Since some motors are not suitable for the model number listed above, confirm the valid combination by the A6 family catalog.
- △ part 2-axis integrated driver S: Serial scale type A: AB phase scale type Refer to the specifications for details.
- For the 2-axis integrated driver, the rated motor output applicable to each axis is shown. Refer to catalogs and specifications for details on combinations.

Model nomenclature

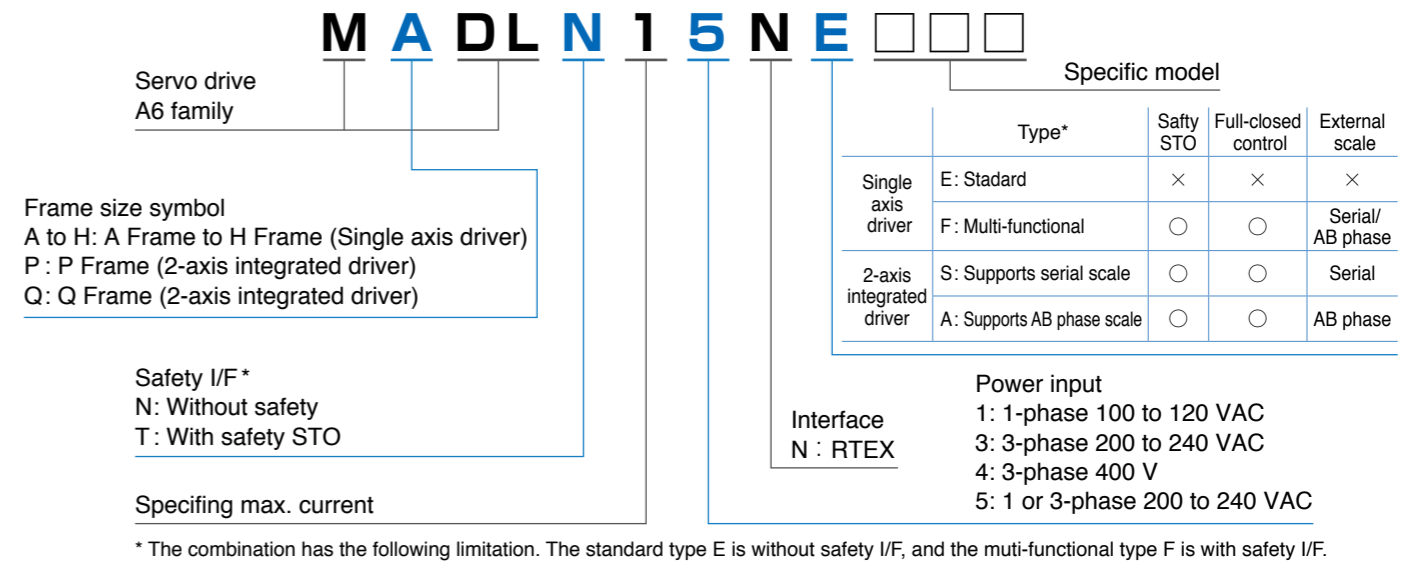

Compliance



*1: Multi-functional type F. IEC61800-5-2 STO, IEC61508 SIL3. *2: The communication period and connection of slave devices depend on the controller specification. *3: For communication period 0.0625 ms, command update period is 0.125 ms only. *4: Slave nodes.

Ultra High-Speed Network Servo MINAS A6N series



Drive appearance

A6N size A

* This photo shows multi-functional type F. Standard type E does not have X3 and X5 connectors.

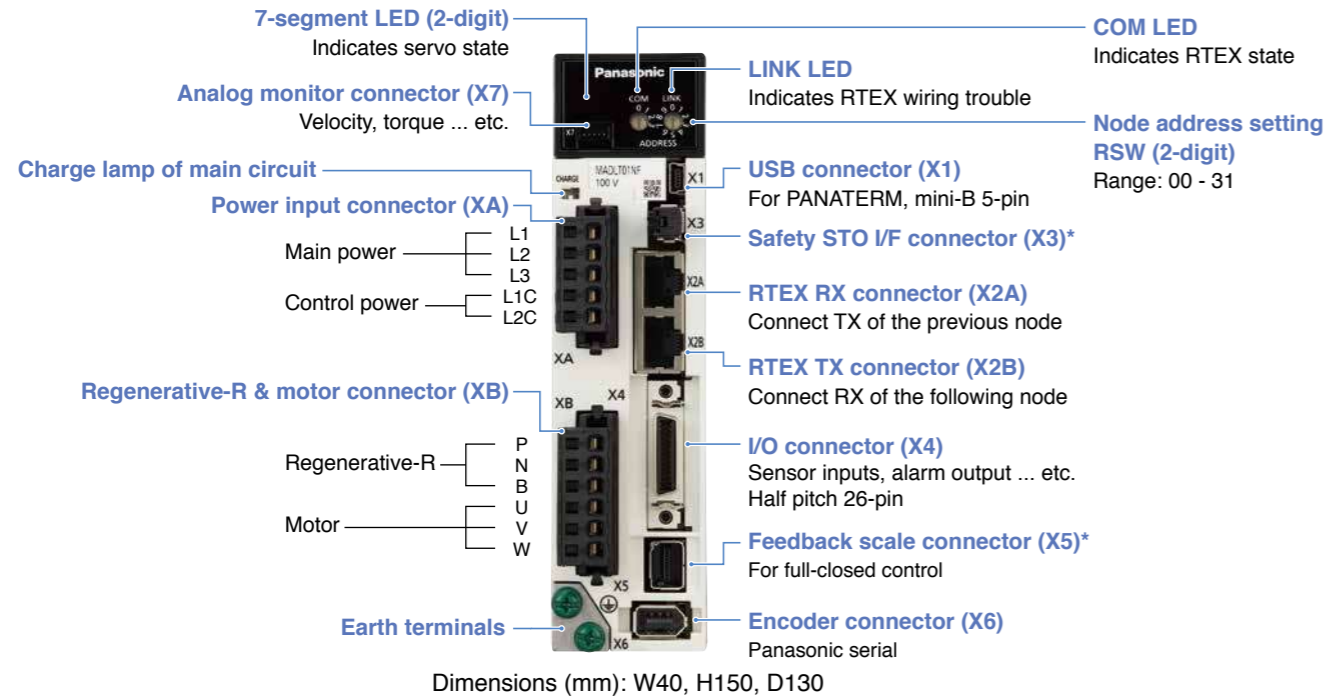

A6N size P (2-axis integrated driver)

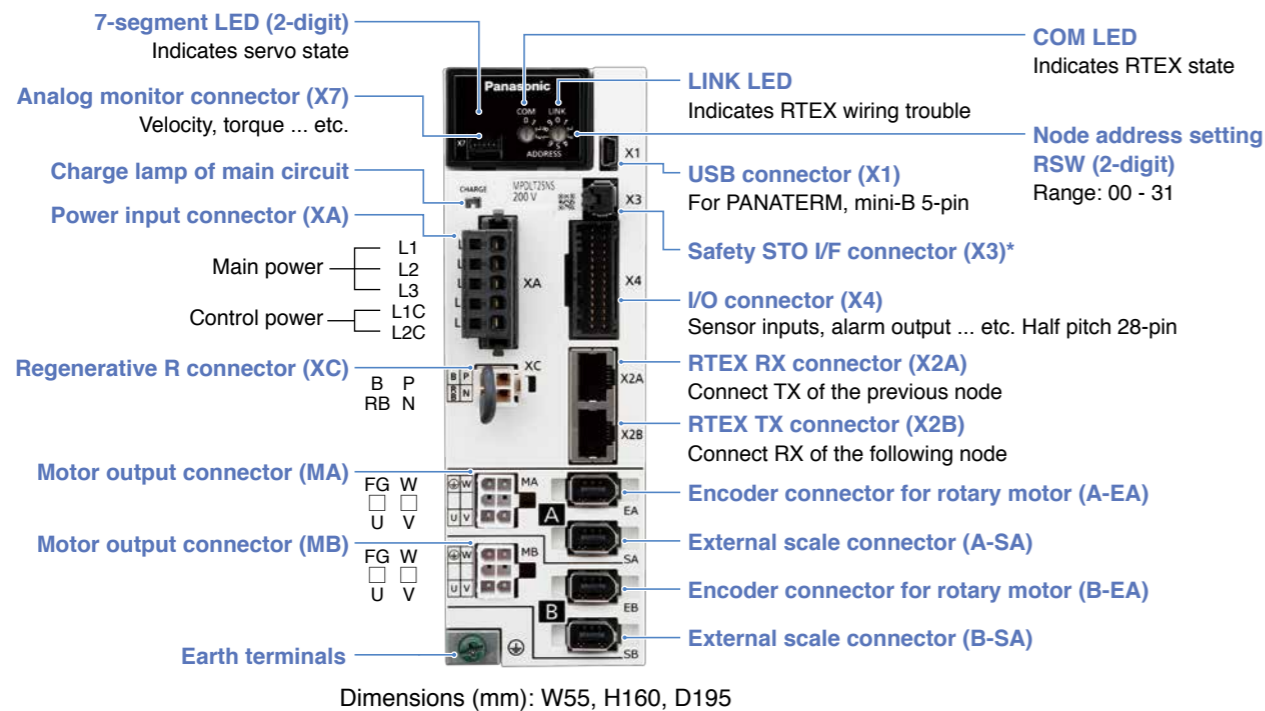

Low voltage small servo MINAS A5MN (DC24 V/48 V 10 W to 30 W)

• This product is not A6N, but A5N series for specific customers. For more details, refer to the specifications.

Drive appearance

A5MN

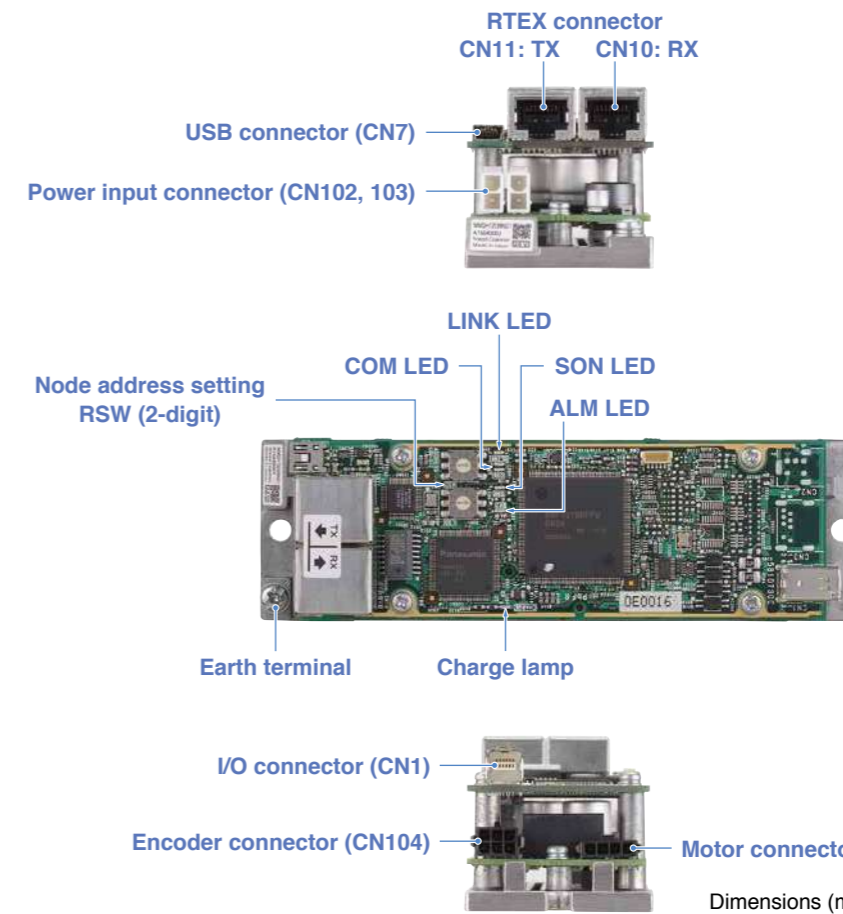

List of drivers

Driver power		Rated output of motor		
		10 W	20 W	30 W
DC 24 V	Frame symbol	M		
	Driver model number	MMDHT2C09ND1		
DC 48 V	Frame symbol	M		
	Driver model number	MMDHT2B09ND1		

• Depending on the motor series, there may be a combination different from the model number in the table, so be sure to check the specifications.

Super high speed network RTEX compatible PLC positioning unit FP0H series, FPXH series

- Corresponding to network servo MINAS A5N / A6N, wiring man-hours are greatly reduced.
- High-speed 100Mbps communication supports high-precision circular / straight / spiral interpolation.
- Realizes multi-axis synchronous control corresponding to electronic gear / electronic clutch / electronic cam.
- FP0H has a maximum of 16 axes. Up to two 8-axis units can be installed. FP-XH can control 8 axes.
- Position command points up to 600 points / axis, position command speed up to 2 Gbps for extra performance.
- Manual pulsar input is installed to enable fine teaching.



System Configuration

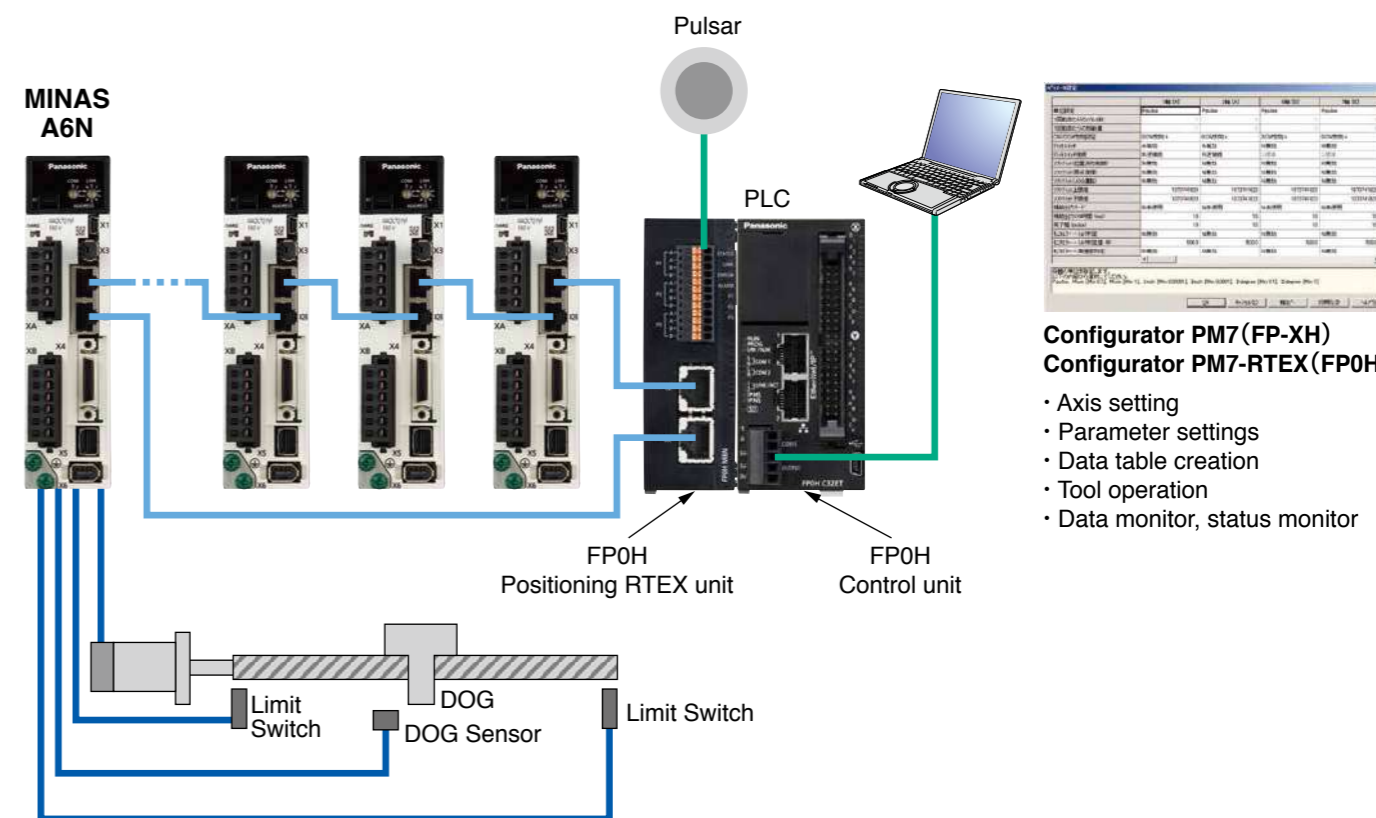

Specification

Model number	FP0H		FP-XH M8N	
	AFP0HM4N	AFP0HM8N	AFPXHM8N16T	
Number of control axes	4-axis	8-axis	8-axis	
Interpolation control	2-axis, 3-axis linear interpolation, 2-axis circular interpolation, 3-axis spiral interpolation			
Position control function	Positioning method	Absolute, increment		
	Positioning unit	pulse/ μ m/inch/degree		
	Positioning range	pulse : -2147482624 to 2147482624		
	Acceleration / deceleration method	Linear acceleration / deceleration, S-curve acceleration / deceleration		
	Acceleration / deceleration time	0 to 10000 ms (Can be set in 1 ms units)		
	Number of positioning tables	Each axis standard area 600 points, expansion area 89 points		
	Control method	PTP control, CP control, JOG positioning control		
Synchronous operation	Number of axes	Number of sync groups	4 groups	
		Master axis	Select from existing axis, virtual axis, pulse input	
		Slave axis	Up to 8 axes per master axis	
	Electronic gear	Operation setting	Gear ratio setting	
		Operation method	Direct method, linear acceleration / deceleration method	
	Electronic clutch	Trigger type	Clutch ON trigger: Contact type, Clutch OFF trigger: Contact input, contact input + phase designation Edge and level selectable for contact method	
		Connection method	Direct method, linear acceleration / deceleration method	
	Electronic cam	Cam curve	Select from 20 types, multiple curves can be specified within phase (0 - 100 %)	
		Resolution	1024, 2048, 4096, 8192, 16384, 32768	
		Number of cam patterns	4 - 16 (Depending on resolution)	
Cam pattern setting method	Cam curve method, cam point method (Set from Configurator PM7-RTEX)	Cam curve method (Set from Configurator PM7)		
その他	Pulsar input operation / High-speed counter function / Dwell time / Torque limit			

Application Sample

- Rotary cutter
- Printing machine
- Inserting machine
- Inspection equipment
- Other general machinery

RTEX Network Motion Controller

PMC-KM2500P

Features

- RTEX (Realtime Express) Network
- PCI Interface
- Max. 16 Axes
- Max. 32 Nodes
- Multi-Axes Motion
- Linear / Circular Interpolation
- Synchronous Control, Gantry Control
- 1D / 2D Position Error Compensation
- Motion API
- Controller Setup Software
- High Speed, High Precision and High Performance
- Very Simple and Easy to Develop Applications



Specification

Item	Description	Item	Description
Interface	PCI 32 bit	Operation System	Windows 7/8/10 (32 bit, 64 bit)
Network	RTEX (100 Mbps)	Network Cable	RJ45, CAT5e STP (Shielded)
Max. Axes	16	Max. Nodes	32
Local I/O	EMG, DI (4 Ch), DO (2 Ch)	Local Counter	2 Ch
Weight	125 g	Operation Temperature	0 °C ~ 50 °C

● Velocity Profile

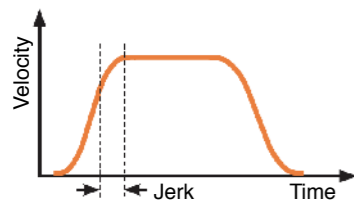

● Motion Command

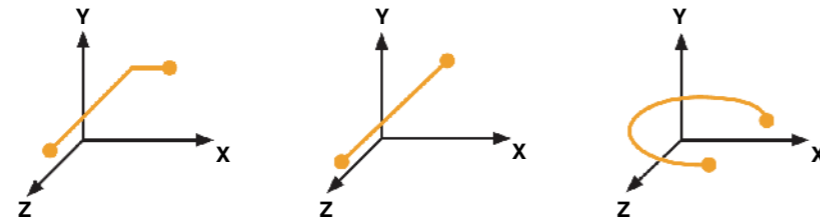

● Change of Command

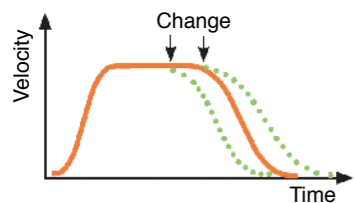

● Gantry Control

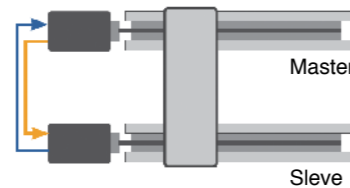

● Position Error Compensation

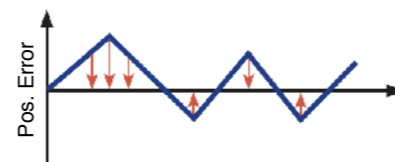

Application Sample

- Semiconductor / FPD Equipment
- Industrial Robot
- Machine Tool
- Other Industrial Equipment

System Configuration

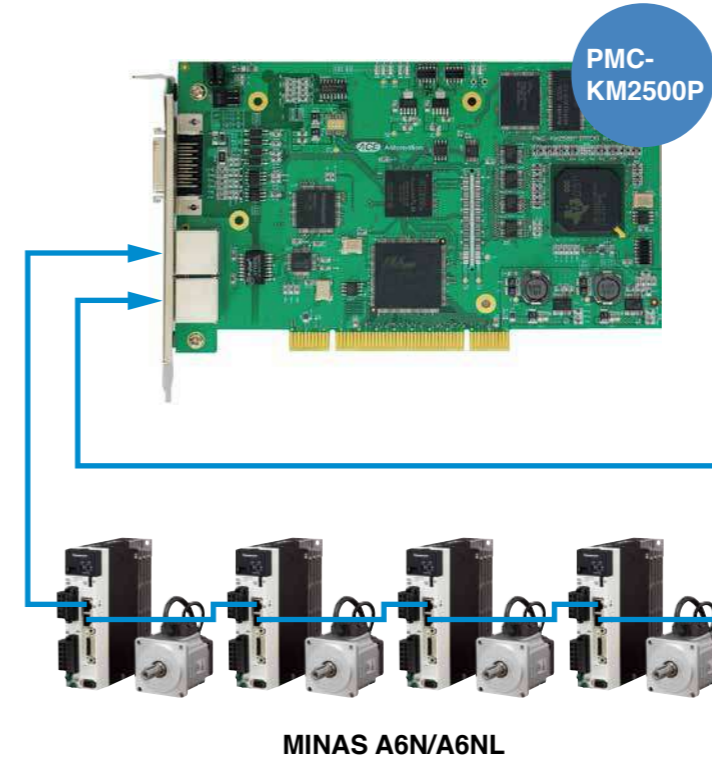

● Controller Setup Software

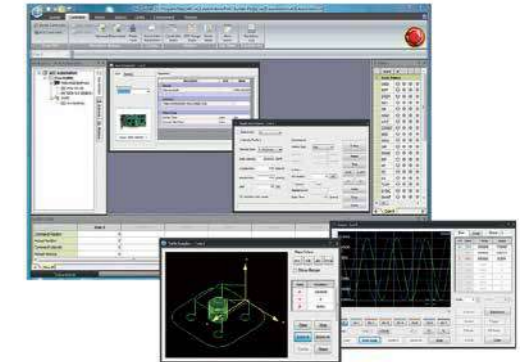

- Controller / Device / Motion Configuration
- Single / Multi / Coordinate Motion
- Path Graph, Realtime Scope
- Servo Configuration
- Monitoring, Diagnosis

Sales area

- Korea
- United States of America
- Japan
- China

Please contact the following address for details.

Language

- Korean
- English
- Japanese
- Chinese

For more information

URL : <http://www.aceautomation.co.kr>

Contact: **ACE Automation Co., Ltd.**

Complex-701, Heungdeok IT Valley, 13, Heungdeok 1-Ro, Giheung_Gu, Yongin-Si, Gyeonggi-Do, 16954, Korea

[E-mail: ace@aceautomation.co.kr]

TEL: +82-31-340-1580 FAX: +82-31-340-1581

RTEX Master Board

PCIe-Rxx04-RTEX, PCI-R1604

Features

- RTEX network Master Board
- Network Speed 100 Mbps, Communication Period 0.5 ms
- Support RTEX Standard Servo Profile, Standard I/O Profile
- PCIe-Rxx04-RTEX Basic configuration is 8 axes control (Can be expanded to 16, 24 and 32axes)
- PCI-R1604 Basic configuration is 16 axes control (Can be expanded to 20, 24, 28 and 32axes)
- Easy to wire, saving wiring working-hour
- Max. 32 nodes
- Network connection - 100 BASE-TX, STP Cable (above CAT5e)
- Excellent Error correction
- Multi-axes linear / circular interpolation
- Limit setting functions : soft stop, emergency stop, and two positions

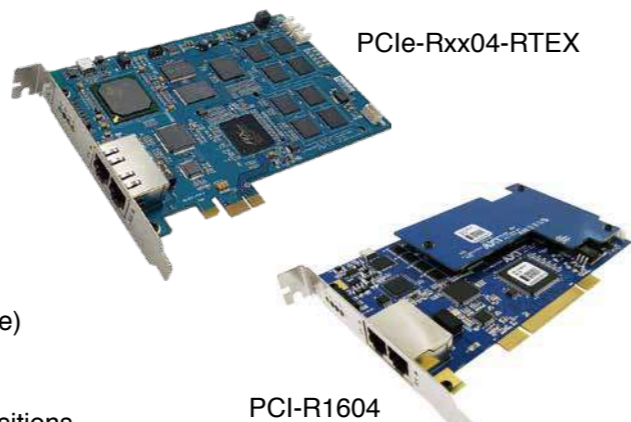

Specification

Item	Description
RTEX Master Board	
Max. number of nodes	32
Max. ring loop length	200 m
Max. node to node length	60 m
Connector / cable type	RJ45 RX/TX, STP (Shielding type)
Power supply / current consumption	3.3 Vdc / 1.5 A (PCIe-Rxx04-RTEX) 5 Vdc / 1.0 A (PCI-R1604)
Position range	32-bit (±2147483648)
Motion	
Interpolation	Max. 32 synchronized drive, 2 to 4 axes linear interpolation, and 2 axes arc interpolation
Gantry motion	Max. 32 slave axes can follow the master axis to move synchronously

Item	Description
Software	
User Agent Software	EzSoftware UC
Operating System	Windows 7 (32-bit, 64-bit) Windows 10 (32-bit, 64-bit)
General specification (PCIe-Rxx04-RTEX)	
Dimension	167.65 mm × 111.15 mm
Weight	116 g
Operation temperature	0 °C to 55 °C
General specification (PCI-R1604)	
Dimension	174.63 mm × 106.00 mm
Weight	120 g (Expend 32axes-161 g)
Operation temperature	0 °C to 60 °C

Application Sample

- Semiconductor front/back end process field
- Solar Energy/FPD/PCB field
- Processing machine field

Please contact the following address for details

URL : <http://eng.ajinextek.com/customer/solution.php>

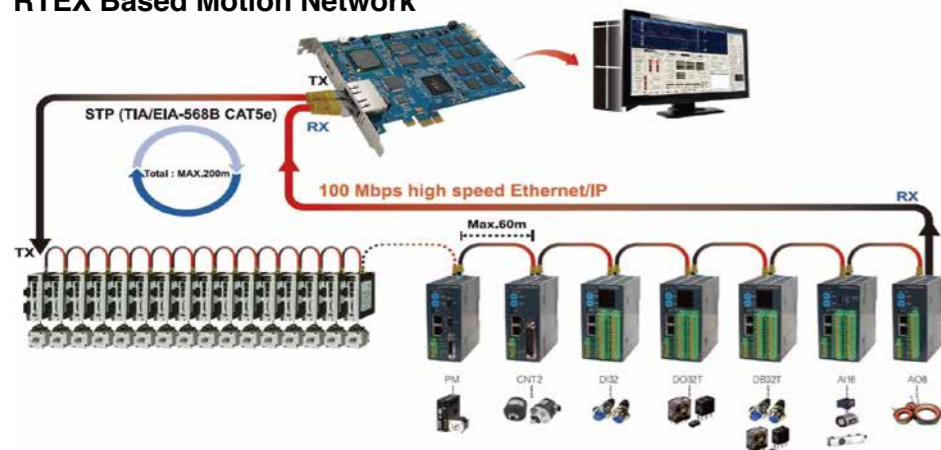

System Configuration

RTEX Based Motion Network





Master Board	PCIe-Rxx04-RTEX PCI-R1604
Motion Module	N3RTEX-PM2Q/4Q
DIO Module	N3RTEX-DI32 N3RTEX-DO32T N3RTEX-DB32T
AIO Module	N3RTEX-AI16 N3RTEX-AO8
Counter Module	N3RTEX-CNT2



Motion Function Module - N3RTEX-PM2Q/4Q, N3RTEX-CNT2

Item	Description		
	N3RTEX-PM2Q	N3RTEX-PM4Q	N3RTEX-CNT2
Model	 2Axes Motion Control Module	 4Axes Motion Control Module	 2ch Counter Module Encoder count range : 28 Bit
Node ID setting	Decimal number rotary switch x 2 (0~31)		
Power supply	DC 24 V / 200 mA		
LED display	Power(Yellow), Link(Green), Error(Red), Communication(Green)		
Pulse output	Interface : Differential	Speed : Max. 10 MPPS	None
Encoder input interface	High-speed Photo-coupler		Line Receiver
Trigger output	Differential, Open collector (24 VDC Level)		Differential, TTL (5 VDC Level), Open-collector (24 VDC Level)
Connector	Comm. : RJ45 LAN x 2EA 26pin axis connector x 2EA 26pin Motion I/O connector x 1EA	Comm. : RJ45 LAN x 2EA 26pin axis connector x 4EA 26pin Motion I/O connector x 2EA	Comm. : RJ45 LAN X 2EA Cnt : D-SUB 25pin X 1EA

Digital Input / Output Function Module - N3RTEX-DI32, N3RTEX-DO32T, N3RTEX-DB32T

Item	Description		
	N3RTEX-DI32	N3RTEX-DO32T	N3RTEX-DB32T
Model	 32ch Digital Input Module	 32ch Digital Output Module	 16ch Digital Input & 16ch Digital Output Module
Node ID setting	Decimal number rotary switch x 2 (0~31)		
Power supply	DC 24 V / 300 mA		
LED display	Power(Yellow), Link(Green), Error(Red), Communication(Green)		
Connector	Comm. : RJ45 LAN x 2EA DINKLE 16 x 2EA (ESC381VM-16P)	Comm. : RJ45 LAN x 2EA DINKLE 16 x 2EA (ESC381VM-16P)	Comm. : RJ45 LAN x 2EA DINKLE 16 x 2EA (ESC381VM-16P)

Analog Input / Output Function Module - N3RTEX-AI16, N3RTEX-AO8

Item	Description	
	N3RTEX-AI16	N3RTEX-AO8
Model	 16ch Analog Input Module	 8ch Analog Output Module
Node ID setting	Decimal number rotary switch x 2 (0~31)	
Power supply	DC 24 V / 150 mA	
LED display	Power(Yellow), Link(Green), Error(Red), Communication(Green)	
Connector	Comm. : RJ45 LAN x 2EA DINKLE 16 x 2EA (ESC381VM-16P)	Comm. : RJ45 LAN x 2EA DINKLE 16 x 1EA (ESC381VM-16P)

General Specification

- Dimension (HxDxW) : 112 mm × 90 mm × 54 mm (N3RTEX-PM4Q, DI32, DO32T, DB32T, AI16)
112 mm × 90 mm × 44 mm (N3RTEX-PM2Q, CNT2, AO8)
- Operation temperature : 0 ~ 55 °C

Sales area

- Korea • China • Taiwan • Malaysia
- Singapore • Vietnam • Philippines

Language

- Korean • Chinese
- English

Please contact the following address for details.

For more information

URL : <http://eng.ajinextek.com/>

Contact: **AJINEXTEK CO., LTD.**

27, Seongseogongdan-ro 11-gil, Dalseo-gu, Daegu, 42714, Rep. of KOREA

[E-mail: marketing@ajinextek.com]

TEL: +82-53-593-3700 FAX: +82-53-593-3703

PLC Direct Access RTEX Motion Controller

PI-2300

Features

Building a leading edge high speed motion network at low cost under PLC

● Direct PLC access

The controller runs the motion program installed in PI while accessing PLC data register.

- Preparation of ladder program for communication is not required on PLC.
- No CPU burden on PLC.

● Simple motion control through data register

Motor can be controlled by operating PLC data register.

- Multiaxial motor can be controlled/monitored by simply operating numeric values on the data register.
- PLC operator having no knowledge on communication of motion (RTEX) can control the motor.

● Stepping motor can be mixed

- The motion network can contain servo motor and stepping motor.
- Ultra high-speed fully-synchronized motion system can be built.



Specification

Item	Description
Power supply	24 Vdc±10 % 300 mA MAX
Operating temperature and humidity	0 °C to 50 °C, 90 %RH max. (no dewing)
Outline dimensions (mm)	W24.5 × D105 × H160
Communication with PLC	Ethernet 10/100 BASE-T Conforms to MC protocol
Setting tool	PI Assistance (complimentary)
Control signal I/O	Initialization input, system alarm output and node alarm output
Motion network	RTEX command updating period: 1 ms
No. of connection nodes	Max. 16
Motion control	Positioning and synchronized operation

2-phase Microstep Drive

D4610 (1 Axis type) / D4620 (2 Axis type)

Features

Leading Edge High Speed Motion Network (RTEX) At Low Cost

● High performance CPU enhances drive capability

- Step-out detection
- Motor over current protection
- Brake control (only D4610)
- Closed loop control by encoder signal (only D4610)
- Triangle drive prevention
- Vibration suppression

● RTEX in motion network

● Network can connect up to 32 axes (depending on master specification)

● Simultaneous multiaxial control within 0.16 ms, 0.5 msec, 1 msec communication period



D4610

D4620

Specification

Item	Description	
	D4610	D4620
Axis	1	2
Power supply	Main power supply : 24 VDC±10 % (3.0 A MAX) Control power supply : 24 VDC±10 % (1.0 A MAX) Sensor power supply : 24 VDC±10 % (0.1 A)	Main power supply : 24 VDC±10 % (5.0 A MAX) Control power supply : 24 VDC±10 % (1.0 A MAX) Sensor power supply : 24 VDC±10 % (0.1 A)
Applicable motor	2.55 A/phase or less 2-phase HB type stepping motor	
Micro step resolution	Basic step divided by 200 (for 40000 p/r basic step 1.8 deg motor)	
Communication specification	Realtime Express (RTEX)	
Input signal	Sensor input 4 (HOME, EX, CWLS, CCWLS), encoder input (only D4610) and stop input	
Output signal	Brake output and alarm output	Alarm output
Protective function	Over current, power supply voltage monitoring and step-out detection(only D4610)	
Environment	Ambient temperature	0 °C to 50 °C (no freezing), Storage: -20 °C to 60 °C (no freezing)
	Ambient humidity	90 %RH max. (no dewing). Storage: 90 %RH max. (no dewing)
	Atmosphere	Indoor (no direct sunshine). No corrosive gas, flammable gas, oil mist, dust, etc.
	Altitude	Max. 1000 m above sea level
	Operating vibration (shock) environment	Max. 2 G (10 Hz to 250 Hz, in X,Y,Z direction 1 hour), max. 10 G (Ones)
Outline dimensions (mm)	160 × 95 × 29	180 × 85 × 35
Mass	275 g	308 g

Application Sample

This controller is suitable for semiconductor manufacturing equipment, machine tools, measuring machines, and other machinery.

System Configuration

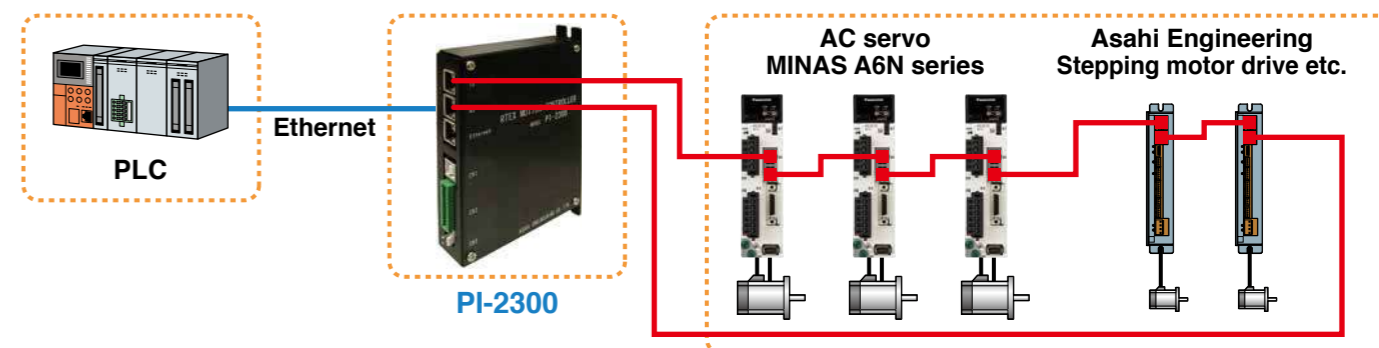

- (1) Accessing PLC data register from PI-2300 over Ethernet
- (2) Based on the contents of data register, the PI sends command to each axis (motor operation).
- (3) The PI writes status information of each axis to data register.

Sales area

- Japan
- China

Language

- Japanese
- English

Only Japanese is used for inquiry over the phone.

When making an inquiry in English, please send it to the following address.

For more information

URL : <http://www.asahi-engineering.co.jp/english>

Contact: **Asahi Engineering Co., Ltd. Kodaira Works**

3-3-22, Gakuen-Higashicho, Kodaira-shi, Tokyo 187-0043, Japan

[E-mail: ae-sales@asahi-engineering.co.jp]

TEL: +81-42-342-4422 FAX: +81-42-342-4423

RTEX Network Motion Control board

MCN-8032P

Features

- RTEX (Real Time Express) servo network
- Network Speed 100 Mbps, communication period 1 ms
- Easy to wire, saving wiring working-hour
- Up to 32 nodes
- Excellent error correction
- Multi-axis linear / circular interpolation
- Multi-axis synchronous motion (for gantry)
- Up to 16 boards in one PC



Specification

Item	Description
RTEX motion control	
Module type support	Servo motor, Linear motor, Stepper motor, I/O module, Pulse module
Max. number of nodes	32 (MCN-8032P)
Max. ring loop length	200 m
Max. node to node length	60 m
Connector / cable type	RJ45 8 pins, STP (Shielding type)
Isolation voltage	1500 Vrms
Noise immunity	Over 2.5 kV
LED loop status	Link / Comm (two elements LED)
Position range	32-bit (± 2147483648)
Motion	
Interpolation	32-axes linear interpolation / 2-axes circular interpolation (max. 16 pairs 2-axes circular interpolation)
Gantry motion	Max. 31 slave axes can follow the master axis to move synchronously
Position compare signal	All servo axis, up to 1 kHz
Software	
Software utility	MCN80XXP series utility for motion test and diagnosis
Driver / LIB	Driver for Windows 7 (64 / 32 bits), Windows XP (32 bits), DLL function for windows applications
General specification	
Certification	CE (applying)
Dimension(LxWxH)	175 mm x 107 mm x 20 mm
Power consumption	5 V / 3.3 V @ 1 A (Max.)
Operation temperature	0 °C to 60 °C

Application Sample

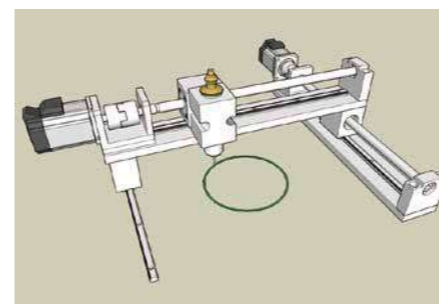

Linear and Circular Interpolations

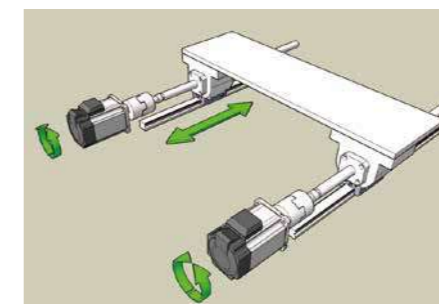

Gantry Motion

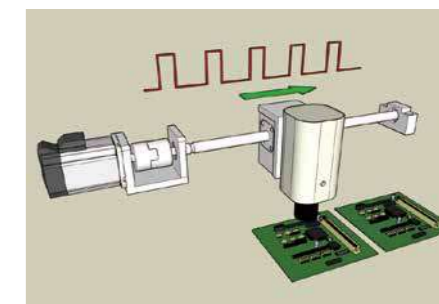

Position Comparing & Triggering Function

System Configuration

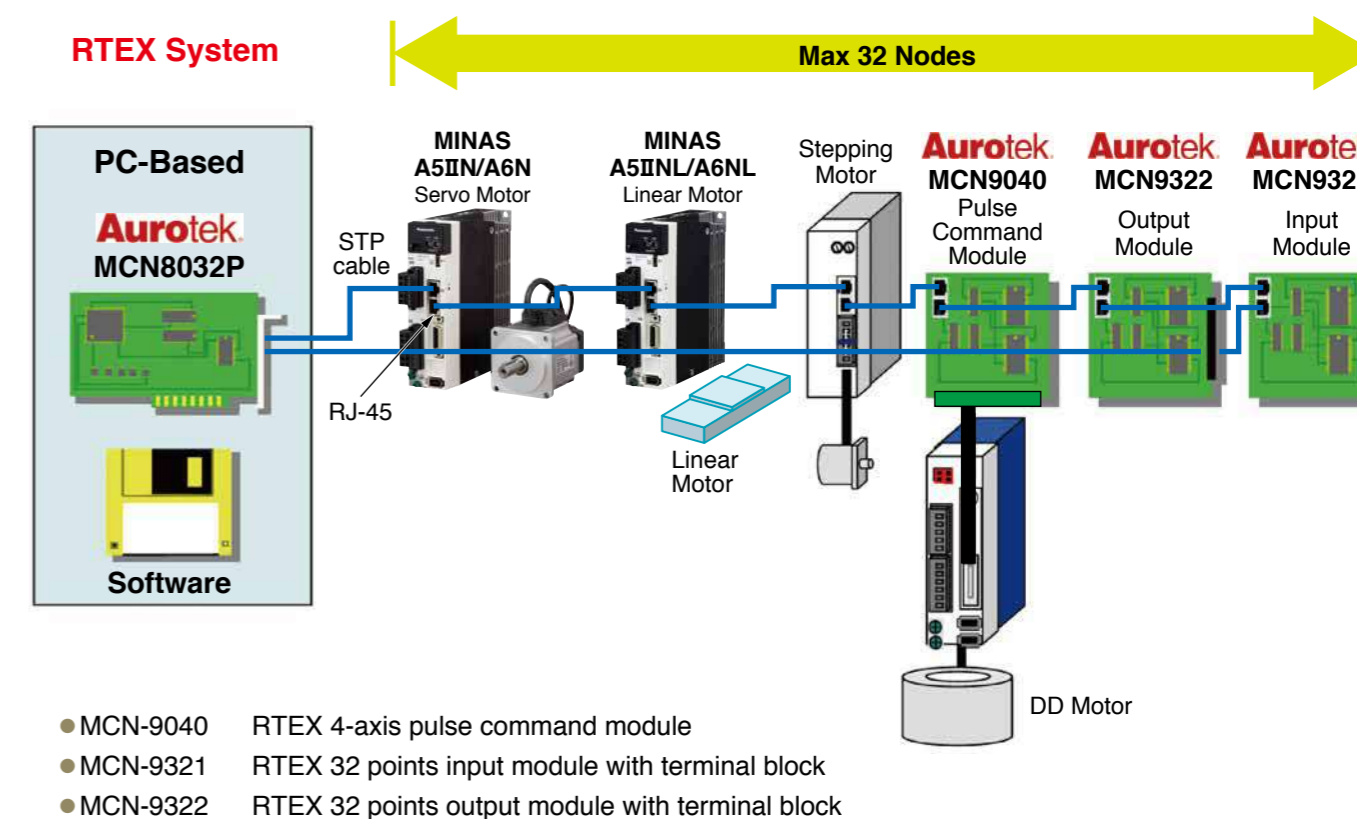

Sales area

- Japan
- Taiwan
- China
- Thailand

Language

- English
- Chinese

For more information

URL : <http://www.robot.com.tw/EN/Default.aspx>

Contact: **Aurotek Corporation**

1st. Floor No. 60, Jhou-Zih St. Nei-Hu District, Taipei 114, Taiwan

[E-mail: sales@robot.com.tw]

TEL: +886-2-6600-7574 FAX: +886-2-8752-3347

Universal Control for Electric Motors OPDE Series

Features

- Synchronous and Torque, Asynchronous and Reluctance Motor Control in a single drive.
- OPD Explorer dedicated tool for drive configuration.
- On Board PLC according to IEC 61131-3 standard.
- Safe Torque Off (STO) function.
- Control of two motors (not simultaneously)
- Variable gain according to the speed
- Positioning and Spindle Indexing (Stop in Position) Application Software
- Notch filters for removing common noise frequencies
- Output Frequency 0 -1300 Hz.
- Switching Frequency (PWM) 3 – 16 kHz.
- Speed loop bandwidth 150 Hz (delay 45°)
- Current loop bandwidth up to 1500 Hz (delay 45°)
- Update cycle internal loop: speed, current, positioning and speed task (62,5 μs)
- PLC Cycle equal to the PWM Cycle.
- 3 fast inputs with sampling time 150 MHz



ENERGY SAVING:

Converter Active Front End acts as an ac/dc rectifier, controlling two-direction exchange of power (absorption or power regeneration) according to the needs of the load.

AFE provides energy savings for all applications that require regeneration of energy in mains, as an alternative to the dissipative braking resistors.

Converter Fundamental Front End acts as an ac-dc rectifier, controlling two-direction exchange of power, according to the needs of the load, without adjusting the Bus DC voltage and THD current.

It works like a diode bridge but it allows to recover energy to the grid as well.

Compared to the AFE there is an increase in current size with a saving in terms of cost and space.

Specification

Size	OPDE																			
	S		M			L	X			1			2			3				
	03	07	12	15	22	32	40	48	60	70	90	110	150	175	220	250	310	370	460	
Overload 120 % x 30 s	POWER kW	1.5	3	5.5	7.5	11	15	20	22	30	37	45	55	75	90	110	132	160	200	250
	I rates (A rms)	3.6	8.3	14.2	17.8	26	37.9	47.4	54.5	68.1	79.3	103	118.4	165.8	195.4	248.6	281.8	348.1	414.4	522.1
Overload 150 % x 30 s	POWER kW	1.5	3	5.5	7.5	11	15	18.5	22	30	37	45	55	75	90	110	132	160	200	250
	I rates (A rms)	3.2	7.4	12.6	15.8	23.2	33.7	42.2	48.5	60.6	70.6	91.7	105.4	147.6	173.9	221.3	250.9	309.9	368.9	464.8
Overload 200% x 30 s	POWER kW	1.1	2.2	4	5.5	7.5	11	15	18.5	22	30	37	45	55	75	90	110	132	160	200
	I rates (A rms)	2.6	6	10.2	12.8	18.8	27.3	34.2	39.3	49.1	57.2	74.3	85.4	119.6	140.9	179.3	203.3	251.1	298.8	376.6
Overload 200 % x 3 s +155 % x 30 s	POWER kW	1.5	3	5.5	7.5	11	15	18.5	22	30	30	37	45	55	75	110	110	132	160	200
	I rates (A rms)	3	7	12	15	22	32	40	46	57.5	67	87	100	140	165	210	238	294	350	441
Size (mm) H W D		303		303			322	322			675			900			900			
		89		116			137	194			251			478			678			
		253		253			253	273			290			296			296			
Weight (kg)	3.5	4.8	5.5	6.4	9.3	10	22			65			80							

Application Sample



● CNC machine tools
Spindle motor



● Five-axis rotary table



● Bending machine



● Cutting machine

System Configuration

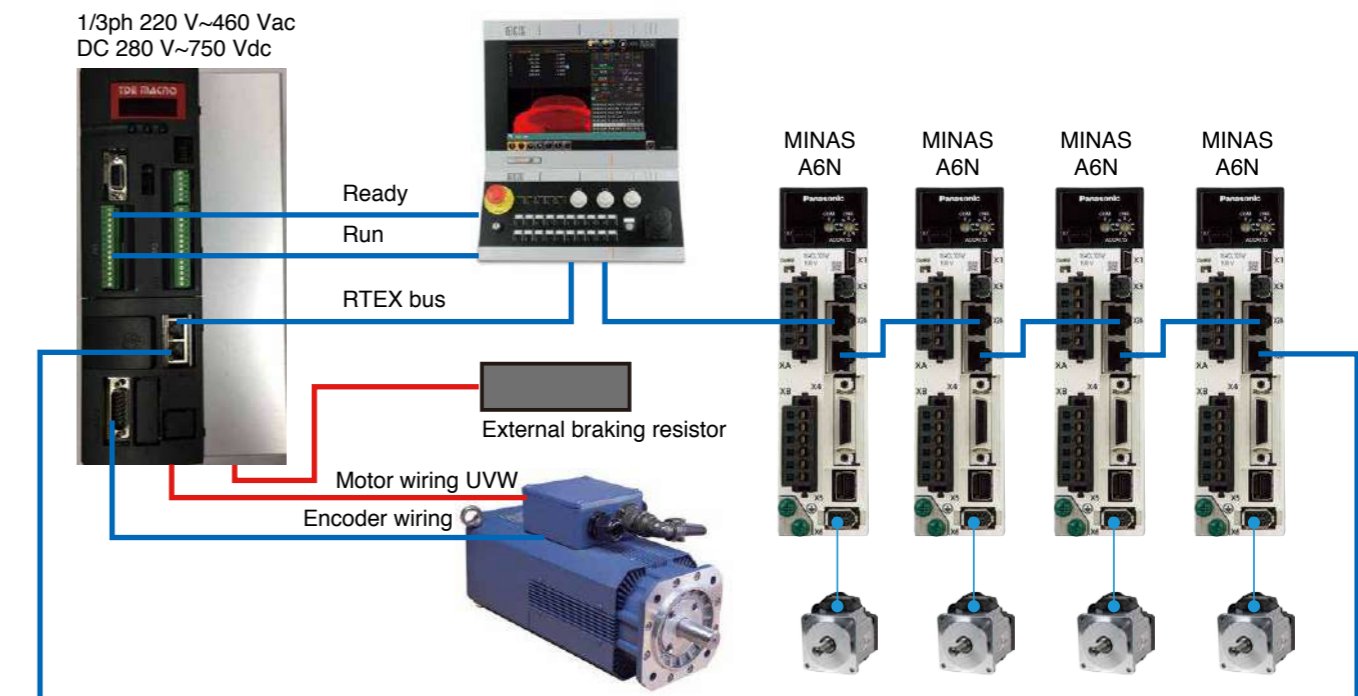

- Feedback:
- TTL Encoder
 - TTL Encoder and Hall sensors
 - Resolver
 - Sin-Cos encoder (incremental and absolute)
 - Endat 2.1 and 2.2 encoder
 - Biss encoder
 - Hiperface
 - Smart-ABS
 - High resolution resolver
 - Hiperface DSL

- Fieldbus:
- Rtex
 - Ethercat
 - Profinet
 - Profibus DP
 - CANopen
 - Anybus CC

Sales area

Language

For more information

URL : <https://www.bdfdigital.com/>

Contact: **BDF DIGITAL S.P.A.**

HEAD OFFICE
Via dell'Oreficeria, 41- 36100 - Vicenza (VI) - Italy

TEL: +39 0444 343555 FAX: +39 0444 343509

PCI-Express RTEX Motion Controller

PXRP-3216CN

Features

- 32 axes for RTEX, 4 axes for Pulse Control, total up to 36 axes.
- A device that cannot be connected to network, such as Stepping motor or Hollow motor, can be controlled by pulse train or I/O Control.
- the Input signal of I/O connector can use either Sink or Source.
- Torque Control or Position Control can be changed freely in Servo Amplifier, Various parameters can be set from Controller directly.
- It is expert in start with Liner or Circular, then Special interpolation control, such as, Ellipse, Cubic Interpolation or Cam action etc.



Specification

Item	Description	
	RTEX Control	Pulse Control
Number of Axis	32 axes	4 axes
Pulse Frequency	1 pps to 400 Mpps	8.191 Mpps
Accelerating/Decelerating function	Liner/S-Curve Acceleration/Deceleration (Asymmetric is OK), Stop Speed	Liner/S-Curve Acceleration/Deceleration (Asymmetric is OK)
Drive function	Absolute (relative) position drive, Continuous drive	
Interpolation function	Liner, Circular, Helical, 3 dimension	—
Synchronous function	Synchronous start, Axle linkage, Gantry Axis	Synchronous start
Override function	Acceleration time, Deceleration time, Object speed, Movement distance	Object speed, Movement distance
Command method	Realtime Express®	DIR/PULSE, CW/CCW, A phase /B phase
Communication/Update period	0.5 msec	—
Bus	PCI-Express Rev1.1	
OS	Windows (32 bit/64 bit) 7 / 8 / 10, INtime, Linux Ubuntu etc.	
Development environment	After Visual studio 2010	

System Configuration

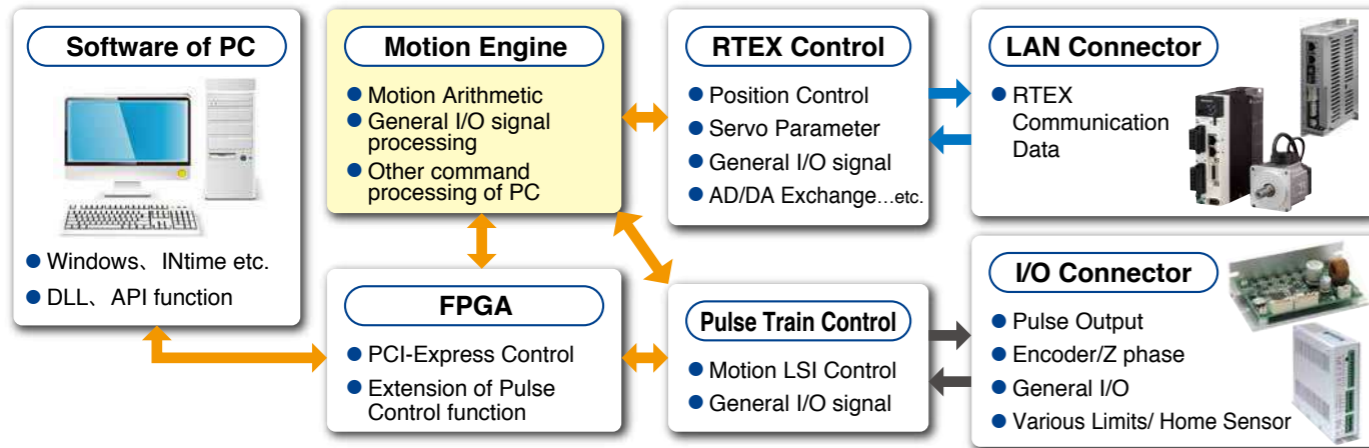

Main functions

Free acceleration and deceleration setting

Starting speed and stopping speed set separately, during working, acceleration time, deceleration time, object speed, movement overrides is possible. Between 1 PPS and 400 MPPS, acceleration and deceleration setting can be set freely in 1msec as a unit.

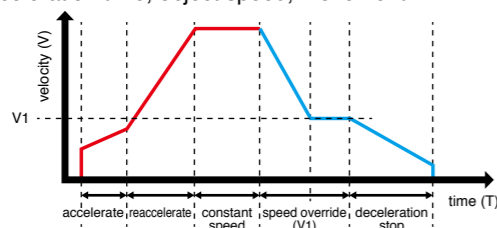

Hard limit deceleration stop function

The Deceleration while hard limit is collided can be overridden.

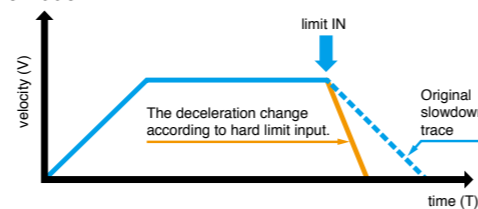

Main functions

Interpolation Control function

Interpolation data up to 5000 steps can be recorded. During working, changing Interpolation data, changing/revising object position, pausing interpolation actions is possible at any time. In addition, from pausing to restarting, exchanging interpolation axis etc, is possible.

example)
The arrival position change image when interpolation is working

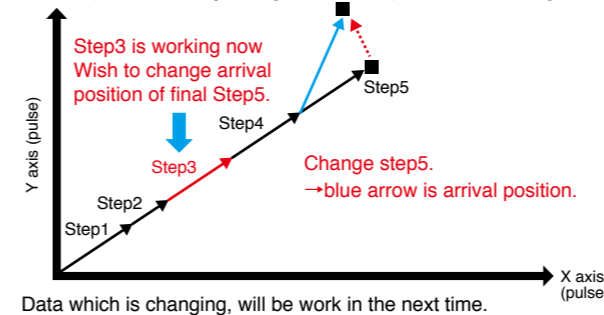

The following image when 7Step is working continuously, it can be stopped at any position.

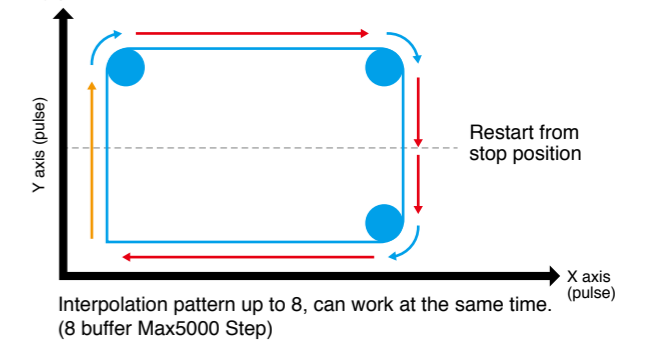

Axle linkage function

Axle linkage function is on one axis we can addition and subtraction command position (output pulse) or actual position (input pulse) of another axis.

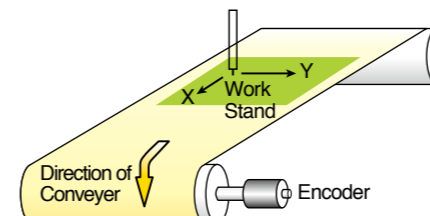

Connect Work Stand (XYZ axis) to the encoder of conveyor, we do not need to stop conveyor to control Work Stand.

Gantry Axis Control

Gantry Axis Control is carried as a base function. Using axle linkage function, connect axis Y2 to axis Y1, then send command to axis Y1 only, axis Y2 is also operating.

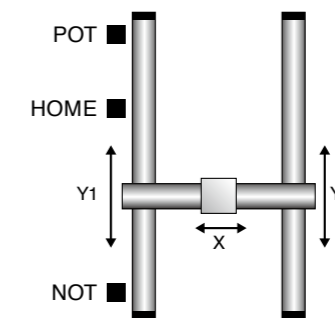

Soft landing function

When to stop the bonding equipment etc., according to the overshoot, shock will happen. Parts may be damaged. Soft landing function can control the overshoot, protects machine, material, or worker.

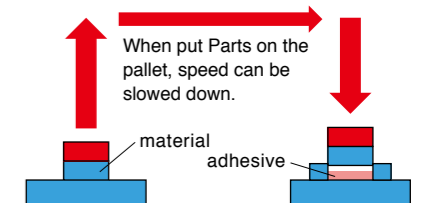

Trigger Input Drive function

Using General input as trigger signal, executing actions that was set beforehand. This function can be used for drive start, synchronous start.

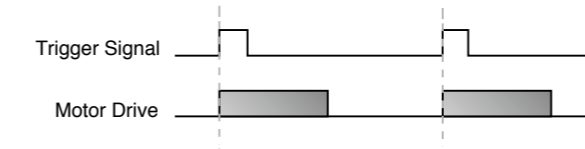

Timing Output function

In the designated position or schedule time, sending output signal. This function can be used for ON/OFF Control of strobe light, camera shutter, sensor etc.

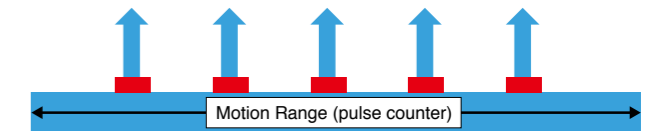

Sales area

- Japan
- China

Please contact the following address for details.

Language

- Japanese
- Chinese

For more information

URL : <http://www.cosmotechs.co.jp/> <http://www.shuitong.net/> (chinese)

Contact: **COSMOTECHS CO., LTD.**

2-6-1 Matsue Atsugi Kanagawa 245-0005 Japan

TEL: +81-49-222-7351 FAX: +81-46-222-7355

PCI Bus RTEX Motor Control Board

PCPG-168N-V / PCMC-168N

Features

PCPG-168N-V

- Control up to 16 axes in 0.5 ms period, accurate and fast control is possible.
- 4 axes pulse train output is possible. Also it can be performed by mixing with Network Control.
- Provide standard device driver, DLL, API

PCMC-168N

- CP Control : besides 16 axes, it can be performed up to 16 axes by PP control or connected to 16 I/O board.
- Max. 32 block can be controlled in 0.5 ms period.
- Provide standard device driver, DLL. We provide sample API to reduce the pressure of user application.



Specification

Item	Description	
Series	PCPG-168N-V	PCMC-168N
Max . Number of Axes	16 axes (CP Control)	CP Control : 16 axes + 16 blocks (I/O or PP Control)
Pulse Control	4 axes (output with RTEX at the same time is possible)	none
Interpolation Control	Liner Interpolation, Circular Interpolation, Continuous Interpolation	Liner Interpolation, Circular Interpolation, Continuous Interpolation
Accelerating / Decelerating Control	Liner Acceleration/Deceleration, S-Curve Acceleration/Deceleration	Liner Acceleration/Deceleration, S-Curve Acceleration/Deceleration
Max . Pulse Frequency	8 Mpps	8 Mpps
Command Updating Period	0.5 ms	0.5 ms

Line-up

● RTEX Stepping Driver

CTDR-0514NS

- 5-phase stepping driver
- CP Control method



CTDR-0514NS-4L

- 5-phase stepping driver
- PP Control method
- 4-axis type



● RTEX Input/Output Module

CTI-16NSW

- 16-point input
- WAGO733 connector
- 2 mA to 5 mA



CTO-16NSW

- 16-point output
- WAGO733 connector
- output : 100 mA



CTI-32NS

- 32-point input
- WAGO733 connector
- 2 mA to 5 mA



CTO-32NS

- 32-point output
- WAGO733 connector
- output : 100 mA



● RTEX Analog Input/Output Module

CTAD-08NSB

- AD converter : 8CH
- Analog ⇒ Digital exchange



CTADA-44NS

- AD/DA converter : 4CH
- Analog ⇔ Digital exchange



● RTEX Pulse Train Output Module

CTPG-48HNS

- Used for PP Control up to 4 axes
- RTEX ⇔ Pulse Train exchange



Stand-Alone Series RTEX Motor Controller

CSRC-32CN

Features

- A Stand-Alone motor control which can control up to 32 axes.
- ECAM, Liner Interpolation, Circular Interpolation, Ellipse Interpolation, Synchronous Control is possible.
- Max. Velocity can reach to 400 M pps, velocity can be changed in 1 ms, and accurate control is possible.
- Positioning data and feedback can be controlled by 32-bit counter. The resolution of Servo can be used flexibly.
- Modbus Touch Panel can be controlled, Stand-Alone Control is also possible.

Specification

Item	Description
Max . Number of Axes	CP Control : 32 axes + Dummy-Axis : 1 axis
Position Control	-2147483648 to 2147483647
Interpolation Control	Liner, Circular, Ellipse, Continuous Interpolation, EAM
Accelerating / Decelerating Control	1 ms to 65535 ms
Pulse Frequency	1 pps to 400 Mpps
Command Updating Period	0.5 ms
Others	It can be used with Modbus. We provide a multiple support tool.



PLC RTEX Motor Controller Module

CPLM-3216N-YE

Features

- Connect to Yokogawa PLC FA-M3.
- CP Control up to 16 axes, also PP Control up to 16 nodes.
- Special Interpolation mix with Liner, Circular, Ellipse Interpolation is possible.
- Max. Velocity can reach to 200 Mpps, velocity can be changed in 1 ms.
- Positioning data and feedback can be controlled by 32-bit counter. The resolution of Servo can be used flexibly.

Specification

Item	Description
Max . Number of Axes	CP Control : 16 axes + 16 blocks (I/O or PP Control)
Position Control	-2147483648 to 2147483647
Interpolation Control	Liner, Circular, Ellipse, Continuous Interpolation, Special Interpolation
Accelerating / Decelerating Control	1 ms to 65535 ms
Pulse Frequency	1 pps to 200 Mpps
Command Updating Period	0.5 ms
Others	WideField3 (Ladder). Provide motion data creating tool.



Sales area

- Japan
- China

Please contact the following address for details.

For more information

Language

- Japanese
- Chinese

URL : <http://www.cosmotechs.co.jp/>
<http://www.shhuitong.net/> (chinese)

Contact: **COSMOTECHS CO., LTD.**

2-6-1 Matsue Atsugi Kanagawa 245-0005 Japan

TEL: +81-49-222-7351 FAX: +81-46-222-7355

Motion Controller (Stand-alone & Remote Control type)

SNET-RTEX Series

Features

- Both Stand-alone & Remote Control
- Adopt standard G code and used Motion Instruction
- Position, Speed change and intervariable calculation using L variable, Macro Function
- PTP/CP/Helical
- Supports communication protocol with PLC, Touch Panel (Melsec etc.)
- 16 Axes - 6 Channel - Multi Tasking
- 2 Port – Supplied external Encoder Input
- Analog In/Out (Option)
- Gantry and Synchronous operation, S-curve, etc
- Remote I/O expansion using RS-485



Specification

	Item	Description
Motion Control	Outline dimensions (W x D x h)	70 mm x 199 mm x 109 mm
	Max. Control Axes	16 (Both Pulse Output)
	Motion Control cycle	1 ms
	Control Method	RTEX (Real time Express)
	I/O Control (PLC)	10 ms
	Multi Channel	6
Interface	SNET-Main	
	EtherNet Port	1ea(100 Mbps)
	RTEX Port	Each 1ea (Rx/Tx)
	RS232 Port	1ea
	RS485 Port	2ea (PLC, Touch etc.)
	SNET-P B□ (Basic)	
	User I/O	16/16
	Pulse Out (Pulse)	6ea (Line Driver)
	External Encoder input1	1ea (Line Driver)
	SNET-A B□ (Basic)	
	User I/O	Each 32/16
	Relay Output	4ea (Max. 800 mA)
	External Encoder input2	1ea (Line Driver)
	Option	
Analog In-Put	4ea (±10 V, 16 Bit)	
Analog Out-Put	2ea (±10 V, 16 Bit)	
Environment	Operating temperature	0 °C to 55 °C
	Storage temperature	-20 °C to 70 °C
Power	Power supply	DC 24 V / 0.75 A / 17 W
Memory	Flash RAM	1.8 M bytes

Application Sample

- Dispenser
- SPI
- AOI
- Packaging Machine
- Laser Application
- Lens Cell Assembly
- OIS Lens Module Assembly
- Lens Module Inspection
- Pick & Place

System Configuration

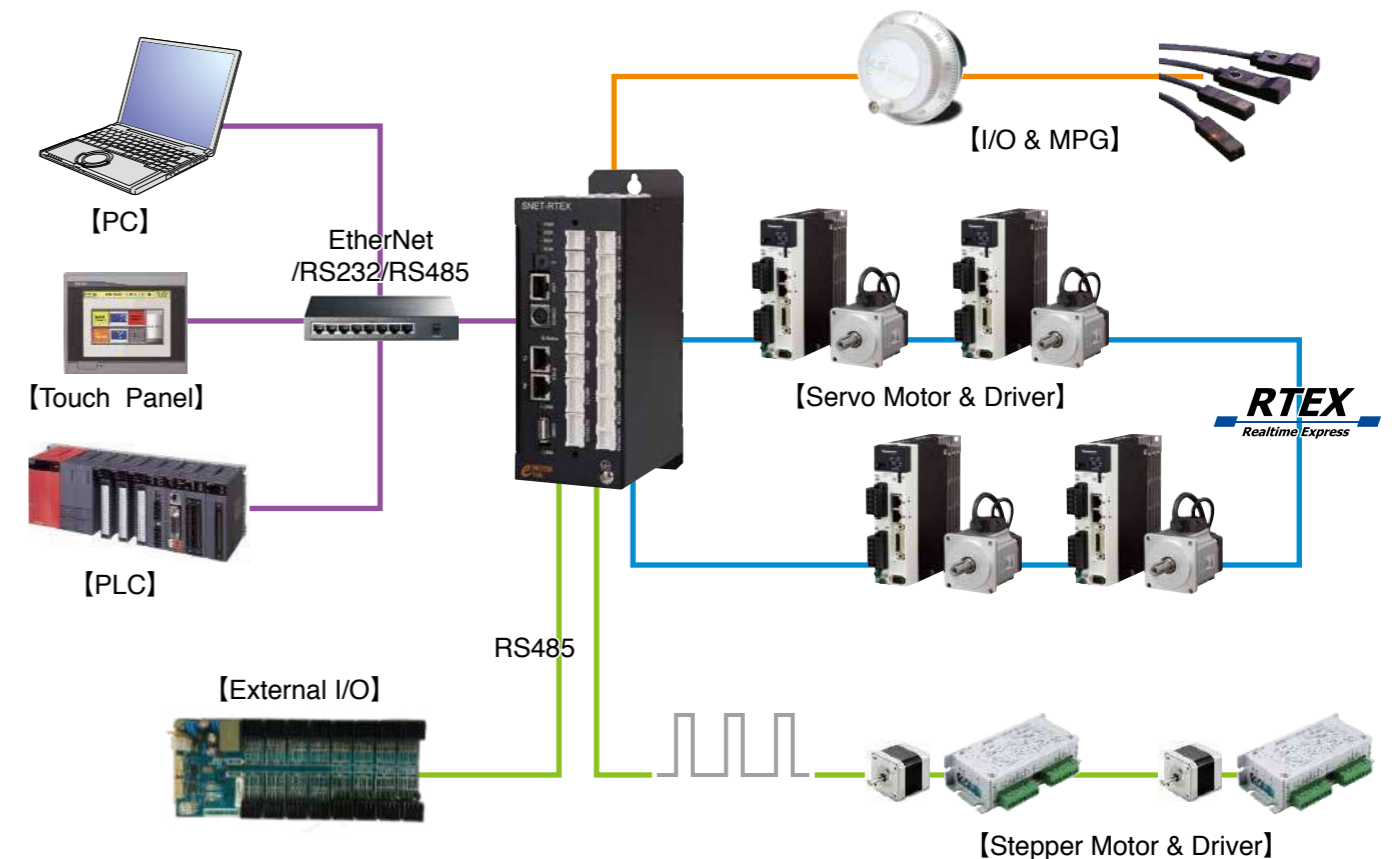

Sales area

- Korea
- China
- United States of America

Please contact the following address for details.

Language

- Korean
- English

For more information

URL : <http://www.emotiontek.com/>

Contact: **eMotionTek Co., Ltd.**

1206,(Byucksan Digitalvalley 5), 244, Beokkot-ro, Geumcheon-gu, Seoul, Korea, 08513

[E-mail: sales@emotiontek.com]

TEL: +82-2-2082-5790 FAX: +82-2-2082-4466

Network Stepper Drive

EM3RT Series

Features



- Support RTEX network protocol
- Perfectly combine with RTEX servo
- Matched motor from NEMA 8 to NEMA 34
- Excellent performance & High reliability
- Easy development & Low cost
- 7 input signals, include 2 differential connections (200 KHz, 3.3 V - 5 V input voltage) and 5 single – ended connections (20 KHz, 12 V or 24 V input voltage)
- 2 output signals, optically isolated, maximum 24 mA/100 mA
- 1 brake output signal, maximum 24 mA/100 mA



Overview

EM3RT series drives are based on Panasonic RTEX network which supports CP operating mode (built in HM mode) and connect up to 32 axes. The products can be combined with RTEX servo drives perfectly and matched with various stepper motors from NEMA 8 to NEMA 34. The EM3RT series has excellent performance including enhanced reliability, super-low stepper noise, anti-resonance and low-speed ripple smoothing and remains low cost.

Specification

Drive Specifications			
Models			
	EM3RT-522	EM3RT-556	EM3RT-870
Operating Voltage	20 VDC - 50 VDC	20 VDC - 50 VDC	20 VDC - 80 VDC
Output Current	0.3 A - 2.2 A (RMS 1.5 A)	2.1 A - 5.6 A (RMS 4.0 A)	2.1 A - 7.0 A (RMS 5.0 A)
Matched Motor	NEMA 8, 11, 14	NEMA 23, 24	NEMA 34

RTEX Specifications

Item	Description
Communication Rate	100 Mbps full duplex
Physical Level	100BASE-TX full duplex (IEEE 802.3u)
Cable	Shielding Ethernet cable (TIA/EIA-568B CAT5e)
Network Topology	Annular
Insulation	Pulsing transformer (in CMV inductor)
Connector	RJ45*2
Max. Cable Length	Node to node:100 m; whole network: 200 m
Noise Immunity	IEC61000-4-4 Level4
Communication Cycle (*)	2 ms - 0.250 ms
Instruction Update Cycle (*)	4 ms - 0.250 ms
Max. Node	32
Synchronization Instruction	CP
Asynchronous Instruction	PP, restart, system ID, home, alarm, parameter, monitor
Data Length	RX: 16 bytes; TX: 16 bytes
Communication Checkout	CRC-CCITT
LED indication (on Rj45)	ERR*1, PWR*1, RUN*1, LINK*1
Application layer	Panasonic RTEX standard

Application Sample

- Automatic production line
- Automation equipment

System Configuration

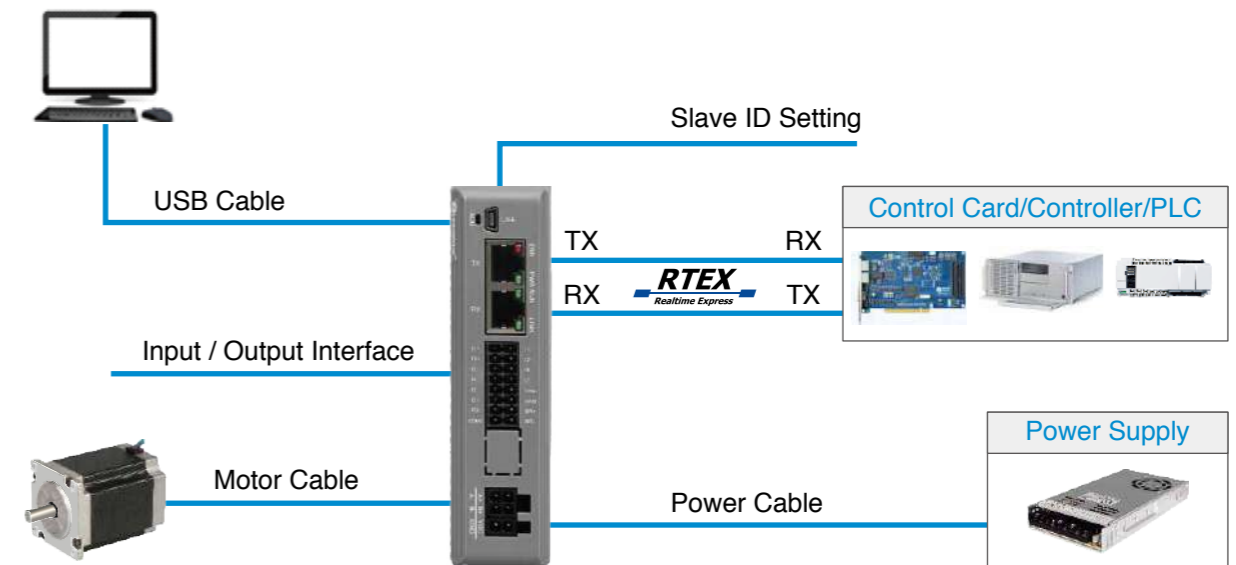

Sales area

- China
- Worldwide response

Language

- English
- Chinese

For more information

URL: <http://www.leadshine.com>

Contact: **Leadshine Technology Co., Ltd.**

11/F, Block A3, iPark, 1001 Xueyuan Blvd, Nanshan District, Shenzhen, China

[E-mail: sales@leadshine.com]

TEL: +86-755-26417674

ETHERNET to RTEX Motion Controller

NMC-XR Series

Features

- 32 axes control is possible with one NMC-XR motion controller.
- It is possible to connect up to 255 NMC-XRs with one low-specification PC.
- **Provide SDK in various languages**
 - Dynamic Linking Library (x32, x64), C, C++, Visual C
 - Labview DLL
- Provide various motion function
 - Multi axis, circular arc, helical, continuous interpolation, list motion, torque value monitoring, etc.
- All 32 SERVO parameters connected to the NMC-XR
Editing is possible at once, You can check motor status information in real time
- Provide a protocol for ModBus.
- **Provide Mirror function**
 - Mirror function copies the motion motion of the main axis like a mirror, It is a special function developed to perform.

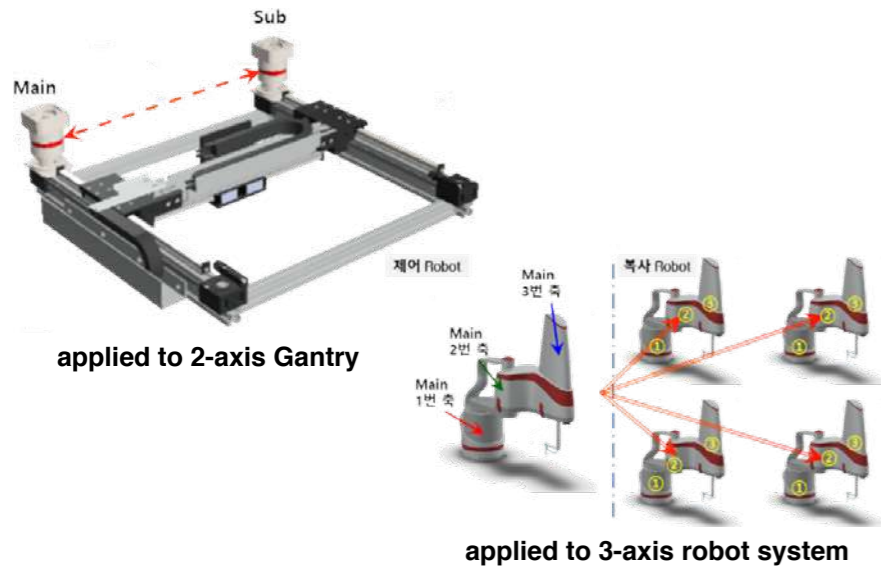

- Real-time Torque Monitoring and Torque Limit
 - You can set the limit range of the instrument as well as perform the origin with the stopper of the instrument.

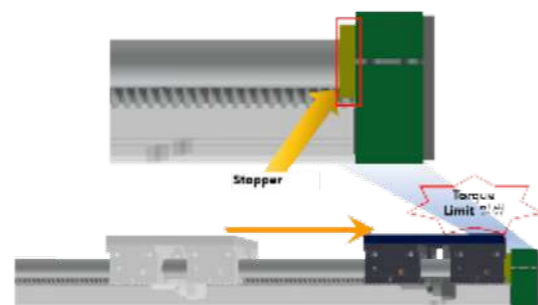

NMC-XR

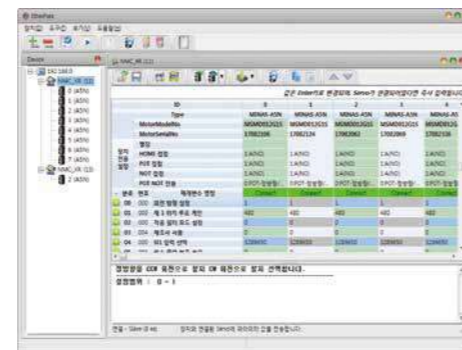

"EtherPara" software

Product Line-up



NMC-XR040
32 axes
(CP 4 axis + PP 28 axis)
digital 8 input + 8 output



NMC-XR080
32 axes
(CP 8 axis + PP 24 axis)
digital 8 input + 8 output



NMC-XR120
32 axes
(CP 12 axis + PP 20 axis)
digital 8 input + 8 output



NMC-XR160
32 axes
(CP 16 axis + PP 16 axis)
digital 8 input + 8 output



NMC-XRDI32
digital 32 input



NMC-XRDO32
digital 32 output

Products that can be used
with the NMC-XR
ETHERNET to PULSE



NMC2E

NMC2E-220 : 2 axis
NMC2E-420 : 4 axis
NMC2E-620 : 6 axis
NMC2E-820 : 8 axis

System Configuration

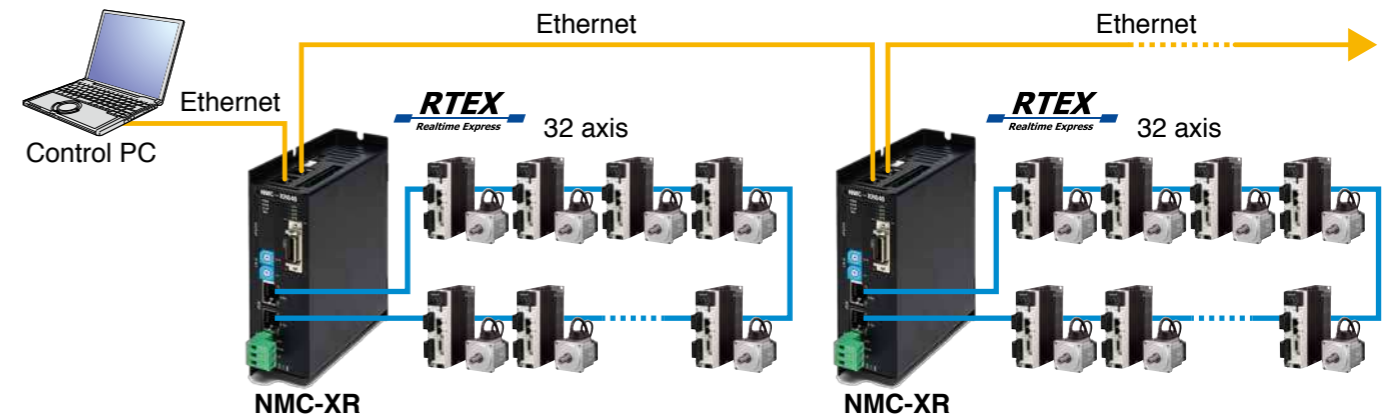

Sales area

• Korea

Language

• Korean

For more information

URL : <http://www.paix.co.kr>

Contact: **PAIX CO., LTD.**

123, Digital-ro 26-gil, Guro-gu, Seoul, Republic of Korea
G PLUS KOLON DIGITAL TOWER #505

[E-mail: mgjung@paix.co.kr]

TEL: +02-833-6663 FAX: +02-833-6667

Multi PLC Direct Connection 16-axis Motion Controller "InterMotion" Series JOY-AMXR-P8 Including PLC (Using a C-like Language)

Features

- Directly connectable to Mitsubishi PLC (CPU with Ethernet: e.g. Q03UDECPU). Reference to the CPU D register in accordance with MC Protocol.
- Directly connectable to Keyence PLC KV-5000. Reference to the CPU D register in accordance with MC Protocol.
- Directly connectable to OMRON PLC (CPU with Ethernet: e.g. CJ1M-CPU11-ETN). Reference to CPU the Data Memory in accordance with FINS commands.
- Control with the .NET Framework interface on a Windows PC with Ethernet is possible.
- Position command generation and DIN/DOUT scan controls with the cycle time of 1ms.



Specification

Item	Description
No. of control axes	16: Max. 16-axis RTEX interface. For max. 8 axes out of the 16 axes, 10Mpps pulse train position command is possible.
Controlling method	Independent PTP control for each axis. Max. 8-axis synchronized PTP control. Linear interpolation, 2-axis arc interpolation, 3-axis spiral interpolation. 32-bit length.
Internal control program development	Control program can be developed using the C-like multiprocessing machine control language "MOS language." Motion control, IO control, communication control, and sequence control are possible. "MOS Bench AM" is required as a development environment.
Accessory IO	±CW/±CCW pulse output, ±A/±B/±Z input. Servo on, reset output. ±OT, alarm input. (The above-mentioned items are for 8 axes.) General-purpose IN 8 points. General-purpose OUT 8 points. Non-insulated RS232-1ch. Insulated RS485-1ch.
Optional functions	Camera trigger function using ±A/±B input counter and general-purpose OUT.
Optional devices	192IN, 192OUT are available by adding 6 general-purpose 32/32 IO boards. Non-insulated RS232-6ch is available using a RS232C extender board.

PCIExpress-40-axis Motion Control Board, PCI-40-axis Motion Control Board "RT40PRE", "RT40PR" Including PLC (Using a C-like Language)

Features

- Max. 40 axes: 32-axis RTEX Interface and 10Mpps pulse train position command for 8 axes.
- Synchronization of axes controlled by RTEX and those controlled by pulse train output is possible.
- Windows Real-time software PLC using the C-like multiprocessing machine control language "MOS language."
- Windows7 Professional 64 bit and 32 bit are supported.
- Windows10 IoT Enterprise LTSB High End is supported.
- DIN, DOUT, AD, DA, RS232, and RS485 can be controlled in real time as well as motion control boards.



General Purpose 32/32 Input/Output Board InterMotion Series JOY-RIO3232

Features

- Single board with 32 IN points and 32 OUT points
- 10 PIN connector for 8-point IN and 8-point OUT. Can be directly connected to terminal block PRS-DG10-O8 (TOYOGIKEN Co., Ltd).
- 24 V DC supply



Specification

Item	Description
Input	32 points (8 points × 4 ports), 24 V _{DC} , 4.7 kΩ
Output	32 points (8 points × 4 ports), 24 V _{DC} , 100 mA
Max. No. of connectable boards	6 (IN 192 points, OUT 192 points)

System Configuration

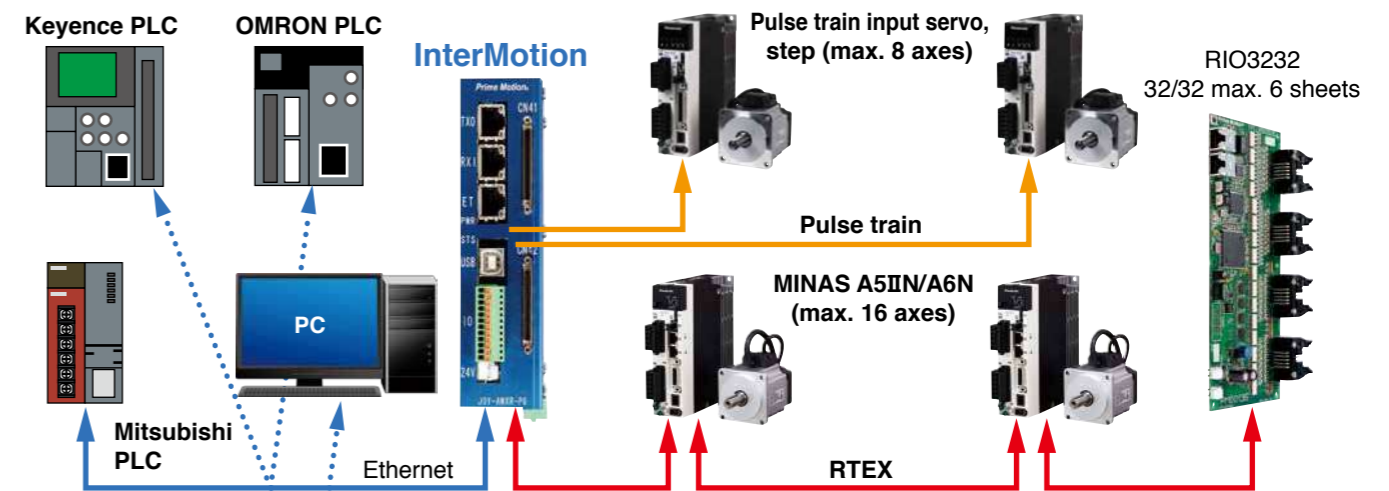

Sales area

- Japan
- China
- Taiwan
- Korea

Language

- Japanese

Please contact the following address directly in Japanese.
Note) Now preparing for a document in English.

For more information

URL : <https://primemotion.com/>

Contact: **Prime Motion Inc.**

1134-12, Akaho, Komagane-shi, Nagano, 399-4117, Japan

[E-mail: info2@primemotion.com]

TEL: +81-265-82-2990 FAX: +81-050-3774-8184

64-Axis Multi-Function Soft Motion Controller

WMX3 for Realtime Express

Features

RTEX and EtherCAT. Soft Motion technology gets the best of both worlds.

- Proven high-performance motion controller WMX3 (patented) now supports "hybrid" networks that simultaneously communicate with the high-speed networks RTEX and EtherCAT. Up to 64 axis synchronous control is possible.
- Applying RTEX to the servo network and EtherCAT to the sub-network enables using cost effective EtherCAT I/O modules.
- Advanced functions such as gantry control and various acceleration/deceleration profiles can be easily realized.

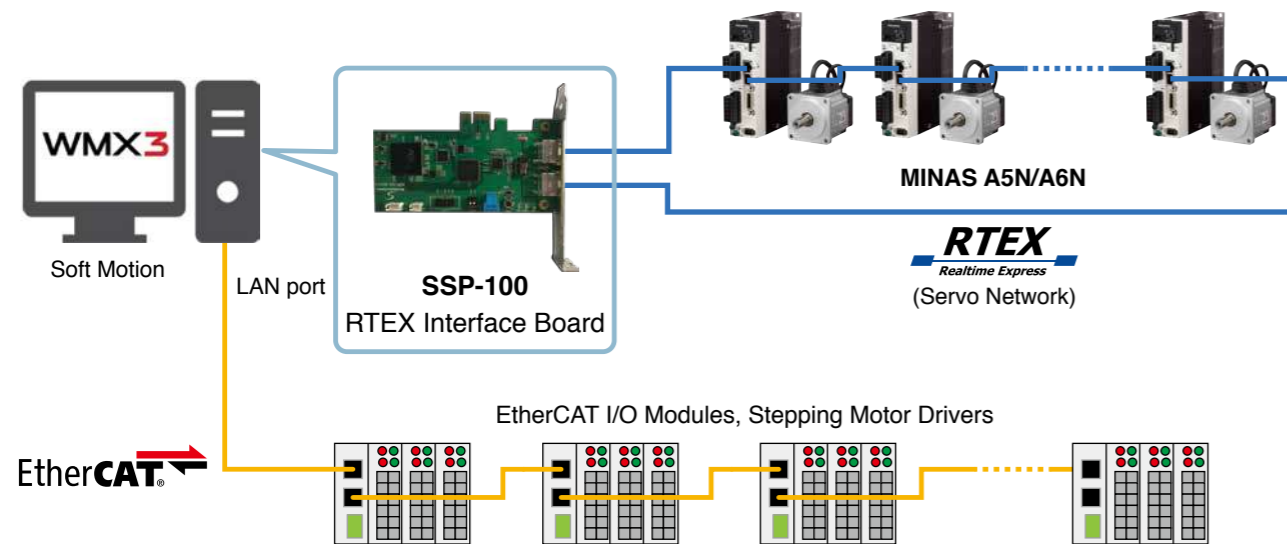

<Advantages of hybrid controls>

If you feel...

- ✓ Not enough I/O points left for operations.
- ✓ A large number of nodes sacrifices the communication cycle.
- ✓ I/O modules are too costly.
- ✓ Want to choose the right I/O module from a lot of options.

Hybrid Network can provide solutions

- ⇒ High-performance RTEX servo network for axis control requiring high synchronization
- ⇒ High cost performance EtherCAT modules for I/O control and stepper motors.
- ⇒ Soft motion enables high-speed real time control over the servo network and I/O network.

Integrated into one PC. Slimming. Networking.

- WMX3 enables the integration of operation screens, image processing, and motion control applications of up to 64-axis for a slimmer control device.
- Reduced wiring man-hours and material costs by reducing wiring through networking. Contributes to noise immunity.
- Use a commercially available Windows PC: Users can freely choose between PCs for small embedded applications as well as high-spec industrial applications depending on the user's application and concept.

Specification (RTEX)

Interface Board (SSP-100)	Low Profile PCI Express, Supports 32-Axis RTEX Communication (64 Axes with two Boards)
Number of control axes	Maximum 64 axes (CP, PTP. when using two SSP-100 boards)
Interpolation Types	Linear (Maximum 32-axis), Arc (2-axis), 3D Arc (3-axis), Helical (3-axis)
Communication/Command Cycle	0.25 ms (16-axis), 0.5 ms (32-axis), 0.5 ms (64-axis, requires two SSP-100 Boards)
Command Modes	Position, Velocity, Torque

Specification (Motion)

Positioning	64-axis * Simultaneous override (Dynamic destination can be changed)
Acceleration / Deceleration Profiles	Speed curve: Trapezoid, S-Curve, Jerk, Two-Step Speed, Acceleration time specification trapezoid, Acceleration curve: S-Curve, Quadratic Curve, Sine Curve
Interpolation Types	Linear, Arc, 3D Arc, Helical, PVT
Continuous Trajectory	Combination of straight line and Arc, Spline interpolation, Automatic prefetch speed control, Linear / Circular continuous trajectory with rotating stage
Gantry Control	Complete synchronous gantry control
Event	Register triggers (reach axis target value, I / O input, etc.) and actions (start axis movement, I / O output, etc.) and execute real-time operations
API Buffer	Register the motion API in the buffer and perform real-time operation. Execution waits and branches can be made depending on conditions.
Position synchronization output (PSO)	Real-time output of I / O at the specified position (position comparison performance depends on the communication cycle). When more precise operation is required, position comparison at 1 pulse level is possible with a dedicated hardware option.
Synchronization Control	Simple synchronization, synchronous gear ratio / offset specification, synchronization deviation correction, dynamic synchronization axis setting / change / cancel. Multiple axes (up to 32 sets for EtherCAT and up to 32 sets for RTEX) can be defined for single-axis to multi-axis synchronization.
Electronic Cam	8 cam curves can be defined. Cam curve for each communication cycle. Phase manipulation. clutch.
Return to Origin	Index pulse, origin sensor, limit sensor, limit proximity sensor, external input signal, mechanical end, etc. It is possible to return to the origin of the gantry axis.
I/O	11600 inputs / 11600 outputs, Supports most commercial EtherCAT I/O modules
Compensation Function	Pitch error, Backlash, Straightness correction
API Supported Language	C Language (C/C++), .NET Languages (C#, VB), .NET Framework: 4.0 or later
Development Environment	Microsoft Visual Studio 2012, 2013, 2015, 2017, LabVIEW, Python 3.6
Recommended Operating Environment	OS: Windows 7(32-bit/64-bit), Windows 10 (64-bit), IoT Enterprise LTSC CPU: Min. ATOM 2 GHz (E3845, etc.) 2 cores or more, Memory: 4 GB or more

Sales area

- Japan
- United States of America
- China
- Korea
- Taiwan

Language

- English
- Japanese
- Korean
- Chinese

For more information

URL WMX3 for RTEX : <https://softservo.co.jp/technology/platform/rtex/>

Contact: **Soft Servo Systems, Inc.**

[E-mail: sales@softservo.com]

3-1-13 AS Building 2F, Nishiki-cho, Tachikawa, Tokyo 190-0022, Japan

TEL: +81-42-512-5377 FAX: +81-42-512-5388

SYNTEC Ethernet-base Controller

Features

- Provide eHMI application for users to customize operation interface conveniently.
- Customized G/M code, dedicated machine can be used easily.
- Provide dipole architecture, users can integrate the customized software on PC.
- Provide optional vision system or pick-and-place equipment for highly automated integration solutions.
- Also supports EtherCAT communication



SYNTEC -E Controller



Keyboard



Control Panel for Mill



Control Panel for Lathe

Specification

Item	Description				
	General Mill-Turn		Multi-Function Milling	Multi-Axis Group Mill-Turn	Five-Axis
Type	21TA-E	21TB-E	21MA-E	210TB-E5	210MB-E5
Axis no.	4	6(8)	6	12(16)	12(16)
DA	2		2	2	2
Max I/O	96/96		96/96	128/128 (RIO, M3IO, SRI)	128/128
Display	8"/10.4"		8"/10.4"/15"	8"/10.4"	10.4"
Servo	RTEX/ECAT		RTEX/ECAT	RTEX/ECAT	RTEX/ECAT
VGA	—		—	1	○*
Connection	Ethernet/RS485/SRI		Ethernet/RS485/SRI	Ethernet/RS485/SRI	Ethernet/RS485/SRI
Multi-Program No.	2		2	4	4
Memory	512 MB		512 MB	4 GB	4 GB
RTCP	—		—	△	△
HPCC	—		—	△	○

* VGA is only provided for the rear half.

- Marking: “○” denotes standard function; “△” denotes optional function; “—” denotes none.
- There are other SYNTEC Ethernet-base Controllers, only a few representatives are listed.

Application Sample

- **Standard Machine:**
Lathe, milling machining center, engraving and milling machine, mill-turn machine.
- **Dedicated machine:**
Tapping center, glass cutting machine, cutter grinding machine, PCB molding machine, spring machine, laser processing machine, flame cutting machine, stone processing machine...etc.



System Configuration

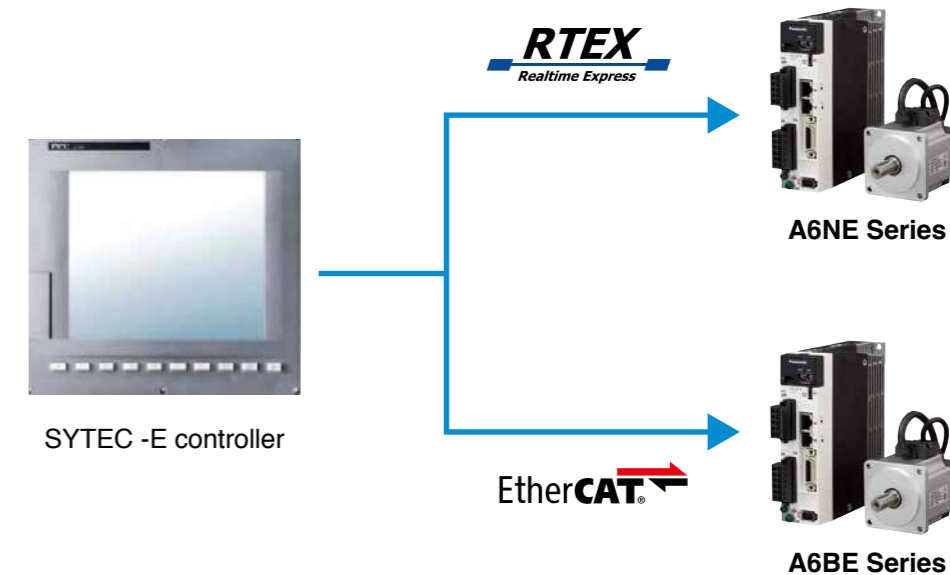

Sales area

- Taiwan
- Malaysia
- Turkey
- China
- Thailand
- Indonesia
- United States of America
- Vietnam

Language

- English
- S/T Chinese

For more information

URL : <https://www.syntecclub.com>

Contact: **SYNTEC Technology Co., Ltd.**

No.25, Yanfa 2nd Rd., East Dist., Hsinchu City 300, Taiwan (R.O.C.)

[E-mail: sales@syntecclub.com.tw]

TEL: +886-3-6663553 FAX: +886-3-6663505

PCI Motion Control Board

169002-MBP-LE01/01, etc.

Features

Motion control board best suited to build motion control system

- **32 axes synchronous control**
 - Servo control of 32 axes in 1 ms period for various applications.
- **Wide array of external interfaces**
 - Because the board is provided with such external interfaces as RS485 communication, 2 external inputs (24 V compatible) and 1 external output, it can be connected to various devices.
 - When multiple inputs/outputs are required, it supports remote I/O function (CUnet).



Specification

Series list			
Model	No. of control axes	Built-in pulse train conversion software	Built-in PLC
169002-MBP-LE01/01	32	-	-
169002-MBP-LE01/02	32	○	-
169002-MBP-LE01/11	16	-	-
169002-MBP-LE01/12	16	○	-
169002-MBP-LE01/21	8	-	-
169002-MBP-LE01/22	8	○	-
169002-MBP-LE01/23	8	-	○

Item	Description	Remarks	
Architecture	CPU	SH4 HD6417750R 200 MHz	
	Memory	FLASH ROM 8 MB	with backup function For data transfer
		SDRAM 16 MB	
		SRAM 128 KB	
		EEPROM 8 KB	
Shared memory 128 KB			
Servo interface	Connector	RJ-45 x 2	
	Interface	Compatible with MINAS A4N/A5IN series	
External input	2 PORT (with sink/source switching)		
External output	1 PORT (with sink/source switching)		
Remote I/O	CUnet		
Serial interface specification	Interface	RS-485	MKY40 (Step Technica Co., Ltd.)
	Transmission rate	115.2 kbps (Max.)	
Compatible OS	Microsoft Windows XP	If you use a different OS, consult us.	

Application Sample

- Semiconductor equipment
- Chip-Mounter
- Machine tool
- Industrial Robot

System Configuration

Sample 1 : In case that the customer develops the motion software

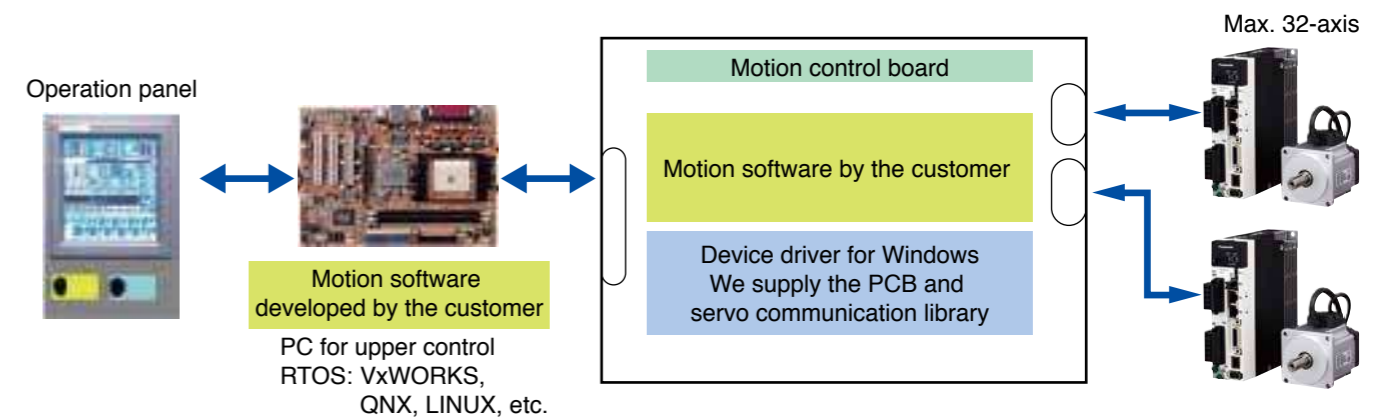

Sample 2 : In case that the customer uses installed software and develops the upper application.

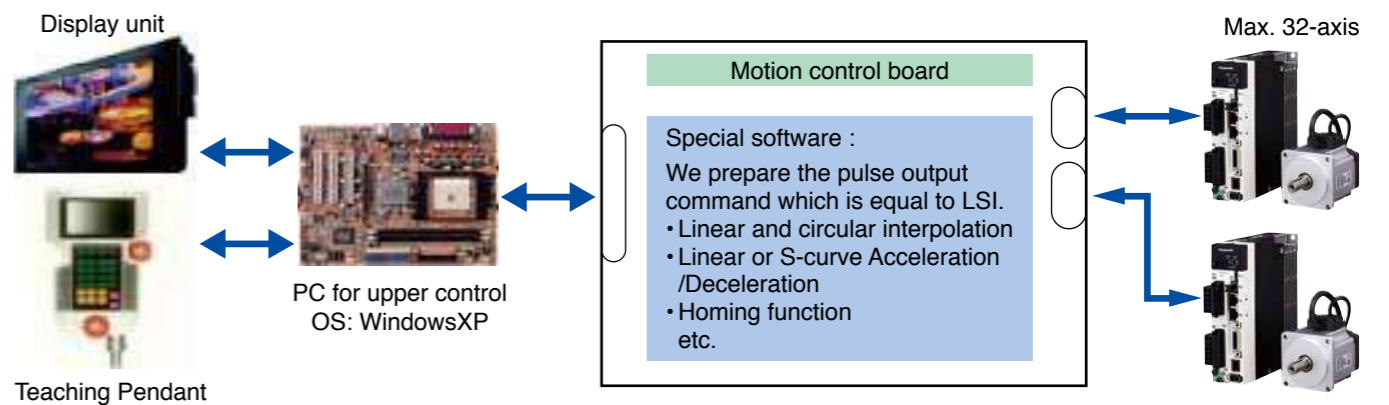

Sales area

- Japan
- China

Language

- English
- Japanese

For more information

URL : <http://www.tietech.co.jp/english/index.html> (Japan)

URL : <http://www.tietech.com.cn> (China)

Contact: **TIETECH Co.,Ltd.**

1-3-4 Shioya-cho, Minami-ku, Nagoya 457-0078, Japan

TEL: +81-52-824-7375 FAX: +81-52-811-4737

PLC Motion Unit

B3632101-UNT-LE02

Features

PLC motion unit best suited to build motion control system

- **32 axes synchronous control**

All servos sync to the host device assuring precise CP control.

Communication period is 1 ms over max. 32 axes allowing various control settings.

- **Software interface easily transportable from pulse train type software**

Command functions such as single axis PTP control, linear interpolation, arc interpolation, origin return and drive parameter change are provided. The unit will operate as the host controller sets the parameters and calls DLL functions. (DLL functions will be disclosed.)

- **Connection of Yokogawa PLC to Panasonic network servo**

By connecting the unit to the host PLC via PCI bus and to the driving section via network interface, various monitoring operations can be performed without stress.

The combination of the unit and PLC expands functions such as to external signal interface.

A4N/A5 II N series
Servo drive compatible



Yokogawa Electric
e-RT3 2.0 series
PLC compatible



Specification

Specification	
Max. No. of control axes	32
Positioning data quantity	No limit
Computing period	1.0 ms
PLC connection	PCI
Interface to servo drive	RTEX 100 Mbps
Continuous servo drive	MINAS A4N/A5II N series
Emergency stop input	According to host PLC specification *1
External signal interface	According to host PLC specification *1
Manual signal pulsers interface	According to host PLC specification *1
Various monitoring	High-speed data processing via PCI bus
Interpolation	Linear, arc, continuous, multiplex, helical pressure control *1

Item	Description	Remarks		
CPU	SH4 7750R 200 MHz (Renesas) Peripheral clock 50 MHz Bus clock 50 MHz			
Memory	ROM			
	Flash ROM	8 Mbyte		
	EEPROM	8 kbyte		
	RAM			
	SDRAM	8 Mbyte		
	DPRAM	256 kbyte		
Bus	PCI bus interface			
	Bus width	32-bit		
	Clock	33 MHz PCI Rev.2.3 compatible		
Power supply	Internal power supply			
	Main power supply	5 V/ 3.3 V		
	CPU power supply	3.3 V, 1.5 V		
	FPGA	3.3 V, 2.5 V, 1.2 V		
Watchdog function	WDT	Watching time 1.6 s		
Monitor	LED	2 points	RUN Green LINK Green	Blinks during operation
Communication	RS232C	1-ch		
	RTEX	1-ch		
Setup	DIPSW	Universal input	4	
		For JTAG.ICE connection	1	
		For FPGA setting	2	
OS		VxWorks6.4		

*1 May be separately defined.

Application Sample

- Semiconductor equipment
- Chip-Mounter
- Machine tool
- Industrial Robot

System Configuration

Sample 1 : In case that the customer develops the motion software

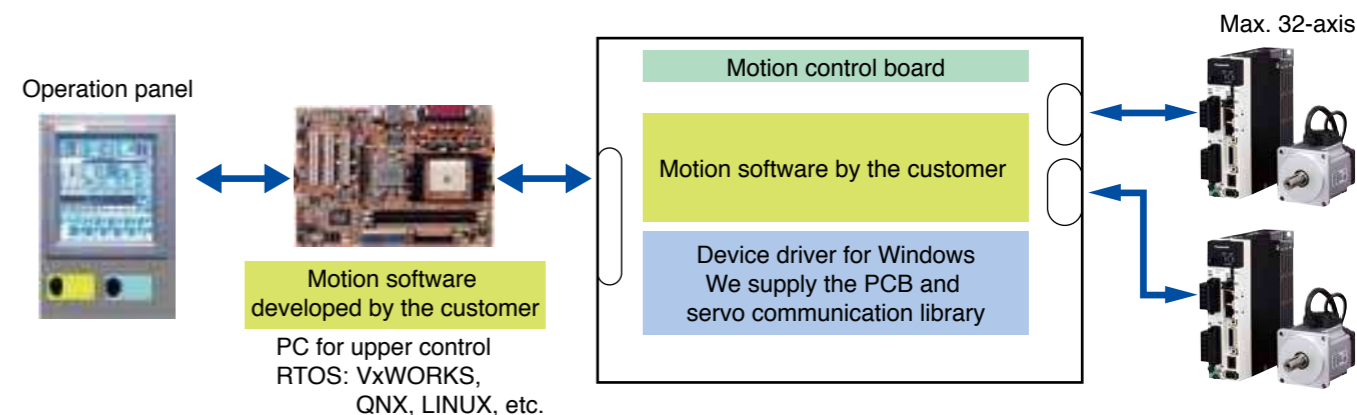

Sample 2 : In case that the customer uses installed software and develops the upper application.

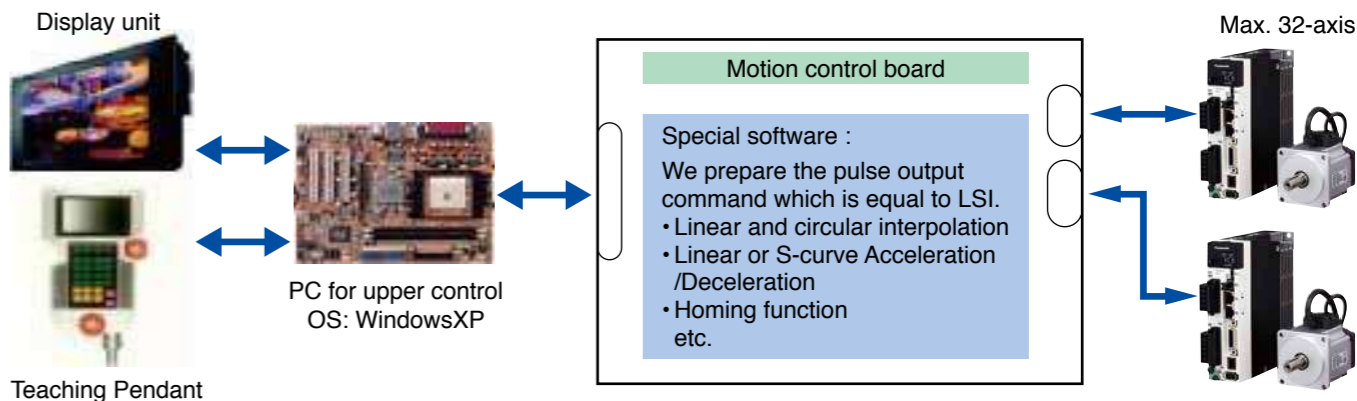

Sales area

- Japan
- China

Language

- English
- Japanese

For more information

URL : <http://www.tietech.co.jp/english/index.html> (Japan)

URL : <http://www.tietech.com.cn> (China)

Contact: **TIETECH Co.,Ltd.**

1-3-4 Shioya-cho, Minami-ku, Nagoya 457-0078, Japan

TEL: +81-52-824-7375 FAX: +81-52-811-4737

Motion Coordinator and RTEX Interface Module

MC664 / MC664-X

Features

- Up to 128 Axes
- Servo period 50 µsec minimum (8 axes)
- Precise 64 Bit Motion Calculations with Quad Core Cortex A9 1 GHz Processor (P862)
- Dedicated Communications Core (P862)
- Built-in EtherCAT Port
- EtherCAT, Sercos, SLM and RTEX Digital Drive Interfaces
- Linear, Circular, Helical and Spherical Interpolation
- Flexible CAM shapes, Linked Motion
- EnDAT, BISS and SSI Absolute Encoder Supported
- Hardware Linked Outputs for Camera / Laser Control
- Ethernet-IP / Modbus TCP / Ethernet Interface Built-In
- Anybus-CC Module for Flexible Factory Comms Including ProfiNet/Profibus
- IEC 61131-3 Programming
- Multi-tasking BASIC Programming
- Text File Handling
- Robotic Transformations
- SD Memory Card Slot
- CANopen + EtherCAT I/O Expansion
- Backlit LCD Display
- RoHS and CE Approved



Specification

Item	Description	Item	Description
MC664 / MC664-X			
Configuration	Axis 0	Extended	
Axes	Max axes	128	Encoder Ports
	Max discrete wired axes	24	
	Max Networked axes	128 (P862) 64 (P861)	
	Max virtual axes	128	
	Max Networked axes	128 (P862) 64 (P861)	
Performance	Processor	ARM A9 (Single/Quad core)	Built-In I/O
	Clock frequency	1000 MHz (Max)	
	Servo update rate	2 ms (4 ms = MC664) -50 µs (8 axes at 50 µs)	
	Encoder input frequency	6 MHz	
	Stepper output frequency	2 MHz	
	User memory	8 Mbyte	Expansion I/O
	Max data table size	512000	
	Flash data memory	32 x 16000	
	VR	65536	
	Position register precision	64 bit	Programming
	Maths precision	Double FP	
	Real time clock	Yes	
	Real time clock	Yes	
	Drive Interfaces	Stepper (Step & Direction)	Option
Servo (±10 V & Encoder)		Option	
Piezo		Option	
Panasonic RTEX		Option	
Hydraulic		Option	
Communication	EtherCAT	YES/Option	Expansion
	Profibus	Option	
	DeviceNet	Yes (slave)	Physical
	CANopen	Yes (server)	
	USB (V1.1)	Option	
	Ethernet (10/100) base-T	Yes	
	Ethernet IP	Yes (server)	Power
	MODBUS-RTU	Yes	
	MODBUS-TCP/IP	Yes	Certification
	RS232/RS485	Yes	
	CC-Link	Option	
	ProfiNet	Option	
	Bluetooth	Option	
	Anybus support	Option	
Hostlink	Yes		

Item	Description	Item	Description
RTEX Interface Specification			
Network	Ethernet based MINAS A4N / A5N / A6N	Bus to MC664	32 Bit
Network Speed	100 Mbps 1 msec or 500 usec update operation	Registration Inputs	8 x 24 V Inputs + 1 Drive Registration Input / Axis
Topology	Ring	Optically Isolated registration Inputs	Yes
Max Slaves per Interface Ring	32	Map Any I/O to Any Axis	Yes
Max Interfaces per MC664	6 (7 with Ethercat)	Supported Modes	Cyclic Position, Cyclic Speed, Cyclic Torque
Max Axes per MC664	128	Axis Feature Enable Codes	P914
Cable	STP Cat 5-e or Better	Certification	UL and CE marked for EMC RoHs Compliant

Application Sample

URL : Sample applications

<http://www.triomotion.uk/public/applications/applications.php>

Please refer to the sample and typical applications for the MC464 with A6N as shown above URL.

System Configuration

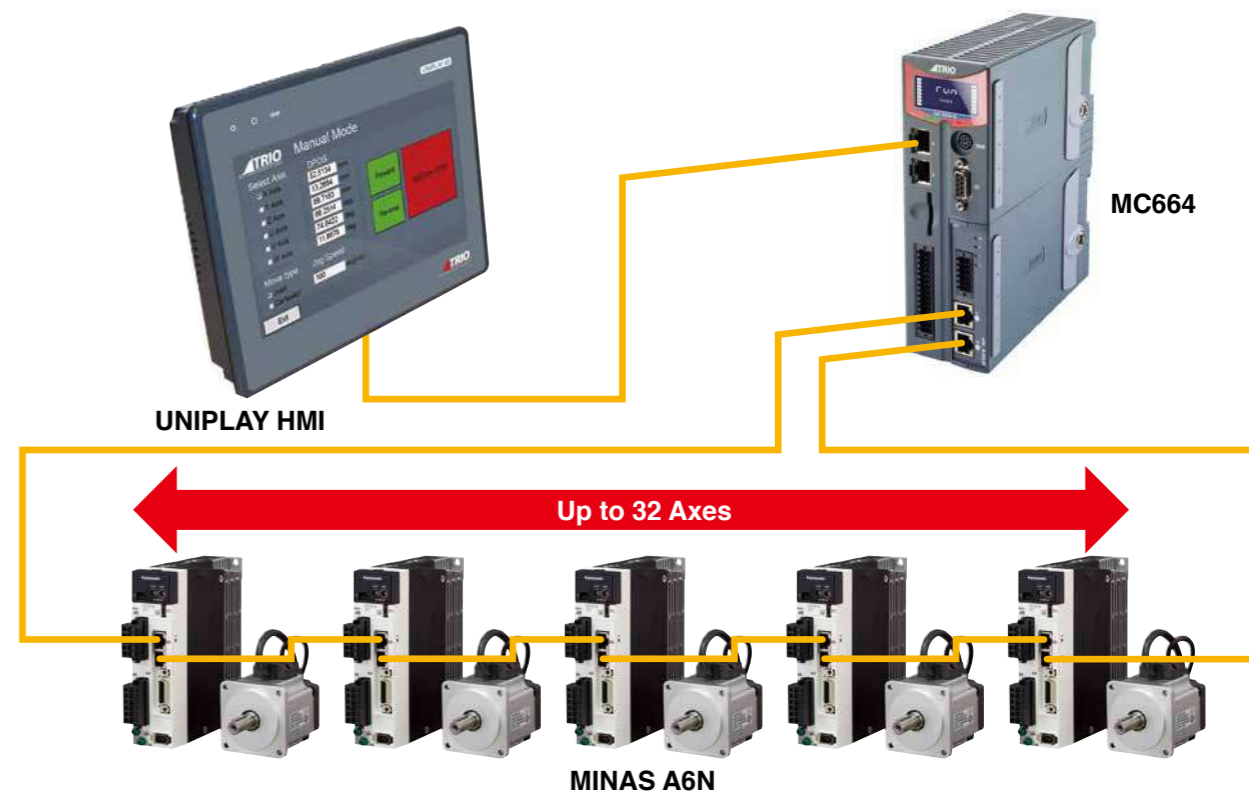

Sales area

- United Kingdom
- United States of America
- China
- India

Language

- English

Please contact the following address for details.

For more information

URL: Panasonic Expansion Module

<http://www.triomotion.uk/public/products/clipOnExpansion.php?tabno=1>

URL: The specifications for the MC664

<http://www.triomotion.uk/public/products/p862.php>

Contact: **Trio Motion Technology Ltd.**

Shannon Way, Tewkesbury, Gloucestershire, GL20 8ND, United Kingdom TEL: +44-1684-292333 FAX: +44-1684-297929

Motion Coordinator and RTEX Interface Module

MC4N-RTEX

Features

- Up to 32 RTEX Digital Drive Axes
- Supports Position, Speed and Torque Drive Modes
- Up to 1024 I/O
- Linear, Circular, Helical and Spherical Interpolation
- Flexible CAM shapes, Linked Motion
- Isolated Encoder Port
- EnDAT and SSI Absolute Encoder Supported
- Hardware Linked Output for Camera / Laser Control
- Ethernet-IP / Modbus TCP / Trio ActiveX / TCIP / Uniplay HMI / UDP / Ethernet Interface Built-In
- Precise 64 Bit Motion Calculations with 532 MHz ARM 11 Processor
- IEC 61131-3 Programming
- Multi-tasking BASIC Programming
- Text File Handling
- Robotic Transformations
- 4 high speed registration inputs
- Isolated RS232 and RS485 ports
- SD Memory Card Slot
- CANopen I/O Expansion
- Backlit LCD Display
- RoHS and CE Approved



Specification

Item	Description	Item	Description	
MC4N-Mini RTEX				
Configuration	Axis 0	Extended		
Axes	Max axes	32		
	Networked axes	32		
	Max virtual axes	32		
Performance	Processor	ARM11		
	Clock frequency	532 MHz		
	Servo update rate	1 ms - 500 µs		
	Encoder input frequency	6 MHz		
	Stepper output frequency	2 MHz		
	User memory	8 MByte		
	Max data table size	512000		
	Flash data memory	32 x 16000		
	VR	4096		
	Position register precision	64 bit		
	Maths precision	Double FP		
	Real time clock	Yes		
	Drive interfaces	Panasonic RTEX	Yes	
Auxiliary Axis		Yes		
Communication	DeviceNet	Yes (slave)		
	CANopen	Yes (server)		
	Ethernet (10/100) base-T	Yes		
	Ethernet IP	Yes (server)		
	TCIP Client	Yes		
	MODBUS-RTU	Yes		
	MODBUS-TCP/IP	Yes		
	RS232/RS485	Yes		
	Hostlink	Yes		
	Encoder ports	Reference input	Yes	
Pulse + direction output		Yes		
Incremental (A+B) output		Yes		
SSI Absolute		Yes		
EnDat Abs		Yes		
Built-in I/O	Inputs 24 VDC	8		
	Bi-directional I/O 24 VDC	8		
	# registration inputs	4		
	Registration input speed	1 µs		
	WDOG output	1		
	Expansion I/O	Digital I/O points	1024	
		12 bit ±10 V analogue inputs	32	
		12 bit ±10 V analogue outputs	16	
	Programming	TrioBASIC	Yes	
# programs		32		
# tasks		22		
IEC61131 Runtime		Yes		
Kinematic Runtime		Option		
G-Code		Application option		
HPGL		Application option		
DXF import		PC Application		
Software	Motion Perfect v4	Yes		
	All Support Software	Yes		
Expansion	Memory slot card	SD		
Physical	Width x Height x Depth (mm)	40 x 157 x 120		
	Weight	432 g		
	Mounting	Panel		
	Operating Temp	0 - 45 °C		
Power	Supply Voltage DC	24 V		
	Consumption (exc. I/O)	350 mA		
Certification	UL Listed	Yes		
	CE approval	Yes		
	RoHS Compliant	Yes		

Item	Description	Item	Description
RTEX Interface Specification			
Max Slaves per Interface Ring	32	Optically Isolated registration Inputs	Yes
Max Axes per MC664	128	Map Any I/O to Any Axis	Yes
Cable	STP Cat 5-e or Better	Supported Modes	Cyclic Position, Cyclic Speed, Cyclic Torque
Bus to MC664	32 Bit	Axis Feature Enable Codes	P914
Registration Inputs	8 x 24V Inputs + 1 Drive Registration Input / Axis	Certification	UL and CE marked for EMC RoHs Compliant

Application Sample

URL : Sample applications

<http://www.triomotion.uk/public/applications/applications.php>

Please refer to the sample and typical applications for the MC4N with A6N as shown above URL.

System Configuration

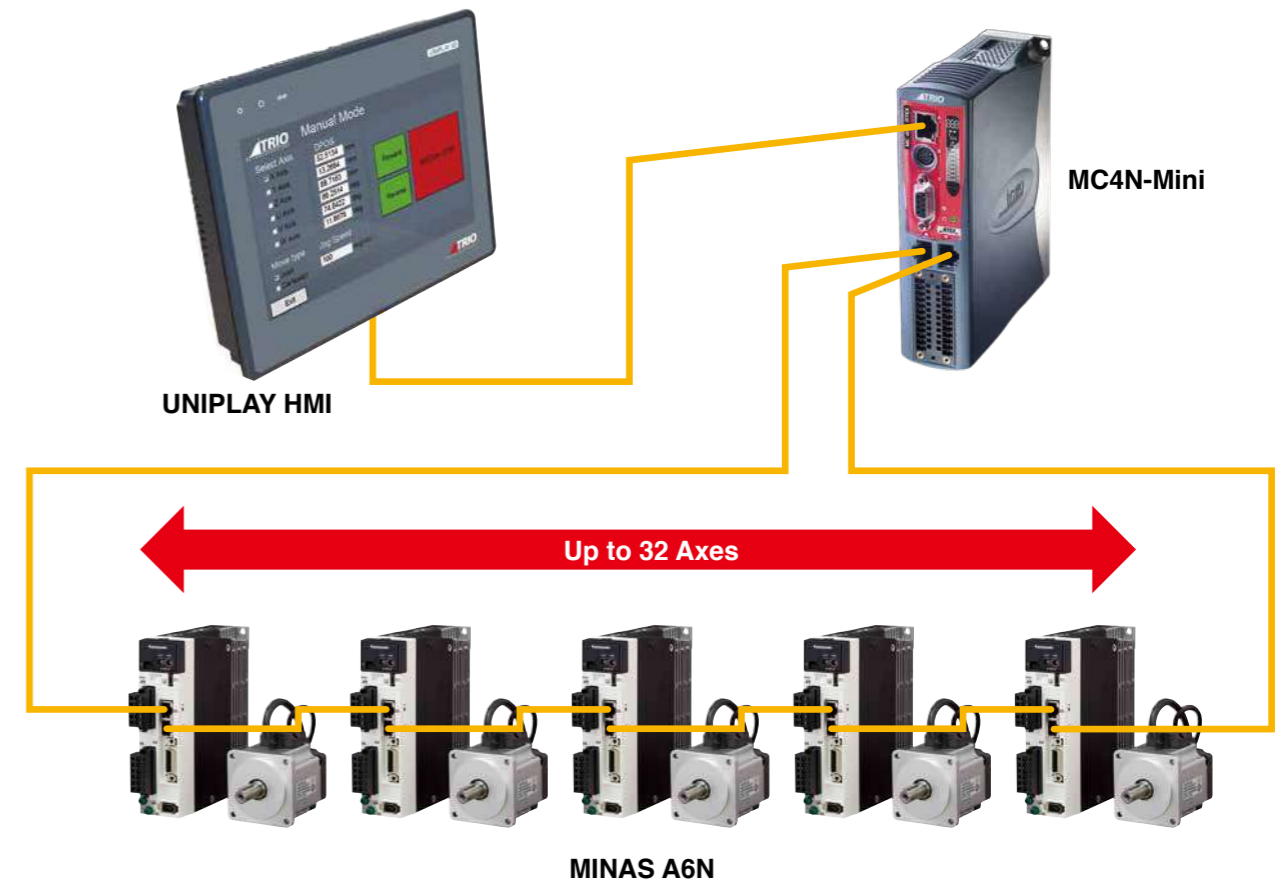

Sales area

- United Kingdom
- United States of America
- China
- India

Language

- English

Please contact the following address for details.

For more information

URL: Specification for the MC4-N RTEX Mini Master

<http://www.triomotion.uk/public/products/p906.php>

Contact: **Trio Motion Technology Ltd.**

Shannon Way, Tewkesbury, Gloucestershire, GL20 8ND, United Kingdom TEL: +44-1684-292333 FAX: +44-1684-297929

RTEX/AnyWire Gateway

AG42-R1

Features

Connect AnyWire Reduced Wiring I/O System to RTEX

- AnyWire reduced wiring system has Dual-Bus function which transfers DI/O and AI/O on the same transfer line but independent of each other.
- AnyWire reduced wiring system is cable free specification and uses general purpose wires
- Layout free, e.g. T branch, multi drop and tree wiring
- Simple one-touch connection, branch and extension by using insulation displacement connector
- Max. No. of I/O points is 2560 and max. No. of units connected to I/O terminal is 128
- Max. connecting route length 1000 m



Specification

Item	Description						
RTEX	No. of exclusive blocks	3 to 11 (depending on No. of points used)					
	Effective data transmission rate	183 kbps/256 points (@ transfer clock: 62.5 kHz)					
	Transmission scheme	Full quadruplex total frame cyclic system					
	Synchronization system	Frame/bit synchronization system					
	Data length/frame	1-bit to 1024-bit					
	Connection topology	Bus (multi drop, T branch, tree)					
	Transmission protocol	Dedicated protocol (AnyWireBus)					
	Error control	Double check					
	AnyWire	Max. No. of connecting I/O points¹	<table border="1"> <tr> <th>Bit-Bus</th> <td>512 points (IN 256 points + OUT 256 points)</td> </tr> <tr> <th>Word-Bus</th> <td>2048 points (IN 1024 points + OUT 1024 points) or 128 words (IN 64 words + OUT 64 words)</td> </tr> </table>	Bit-Bus	512 points (IN 256 points + OUT 256 points)	Word-Bus	2048 points (IN 1024 points + OUT 1024 points) or 128 words (IN 64 words + OUT 64 words)
		Bit-Bus	512 points (IN 256 points + OUT 256 points)				
Word-Bus		2048 points (IN 1024 points + OUT 1024 points) or 128 words (IN 64 words + OUT 64 words)					
Max. No. of connected units		128 (Total of Bit-Bus terminals and Word-Bus terminals)					
Max. cycle time²		[0.85 ms/128 points], [1.4 ms/256 points], [2.4 ms/512 points], [4.4 ms/1024 points] (transfer clock @62.5 kHz)					
RAS function		Transmission line breakage position detection and transmission line short-circuit detection					
Transmission cable³	Cable free • General purpose (VCTF) 2-core /0.75 mm ² to 1.25 mm ² : transmission only (D, G) • General purpose (VCTF) 4-core /0.75 mm ² to 1.25 mm ² : including power supply (D, G, 24 V, 0 V) • Other general purpose cables /0.9 mm ² to 1.25 mm ² : e.g. parallel • Special flat cable /0.75 mm ² to 1.25 mm ² : including power supply (D, G, 24 V, 0 V)						
Max. transmission distance⁴	[1 km/7.8 kHz] [500 m/15.6 kHz] [200 m/31.3 kHz] [100 m/62.5 kHz]						

*1: The number depends on the master. *2: Typical values at the top speed. *3: Diameter varies with transmission distance.

*4: Distance is the cable total length.

Sales area

- Japan

Language

- English
- Japanese

Only Japanese is used for inquiry over the phone.

When making an inquiry in English, please send it to the following address.

For more information

URL: <http://www.anywire.jp/>

Contact: **Anywire corporation Headquarters**

[E-mail: info_e@anywire.jp]

1 Babazusho, Nagaokakyo-city, Kyoto 617-8550, Japan

TEL: +81-75-956-4911(Japanese only) FAX: +81-75-356-1613

* Only Japanese is used for inquiry over the phone. When making an inquiry in English, send it to: info_e@anywire.jp.

RTEX corresponding table and ASIC information

RTEX partner products

[Corresponding table]

Partner	Master				Slave							
	PCI	PCI-e	Stand Alone	PLC	Digital I/O	Analog I/O	Pulse Output	Stepper Driver	Counter	Gateway	Motor Driver	Servo
Panasonic Corporation				●								●
ACE Automation Co., Ltd.												
AJINTEK CO., LTD.	●	●			●	●	●		●			
Anywire Corporation										●		
Asahi Engineering Co., Ltd.			●					●				
Aurotek Corporation	●				●		●					
BDF DIGITAL											●	
COSMOTECHS	●	●	●	●	●	●	●	●				
eMotionTek Co., Ltd.			●									
Leadshine Technology Co., Ltd.								●				
PAIX CO., LTD.			●									
Prime Motion Inc.	●	●	●		●							
Soft Servo Systems, Inc.	●											
SYNTEC Technology Co., Ltd.			●									
TIETECH Co., Ltd.	●			●								
Trio Motion Technology Ltd.			●									

Communication ASIC MNM1221

For developing RTEX product, this ASIC is necessary. (See note)



	Specification
Part No. for ordering	DV0P444-9
Packing quantities	90
Power supply voltage	3.3 V
Current consumption	Max. approx. 100 mA (for reference)
Operating ambient temperature	-40 °C to +85 °C
Package	LQFP100pin 14 mm × 14 mm Lead pitch 0.5 mm
RoHS	Compliant
Operation mode	Master/slave

Note: As long as the target is noncompetitive to Panasonic products.

High-Performance

- Frequency response: **3200 Hz**
- Supports network communication “**EtherCAT**”.
- High-Speed **100 Mbps**
- Real-time auto tuning function, Anti-vibration filters are available.

Operability

- Smallest **EtherCAT** drive in market.
- **Wireless connection** using wireless LAN dongle (option)
 - Wireless connection with PC and smartphone via access point by just mounting to servo driver.
- Supports pc setup software “**PANATERM**”
- Lifespan diagnosis/Deterioration diagnosis
 - Warning output for Servo (motor and driver) lifespan and machine deterioration limit.



• Record/play objects by waveform function



• Status monitor (with playback function)



• Deterioration diagnosis setting screen

High-functions

- **EtherCAT** with many supported applications <7 control modes, 32 hm methods, DC(Synch), SM2(Synch), FreeRUN (Non-synch)>
- System-up possible with various slaves.
- Supports PC-based controller.
- A6BL/A6BM (for Linear Motor) will be available soon.

Wireless LAN Dongle (Option)



Standards EtherCAT

- Official EtherCAT Conformance Tested model available.
- IEC safety I/F model available.*1 *1:Supported by multifunction type. EN61800-5-2 STO, EN61508 SIL3.

[System configuration example]

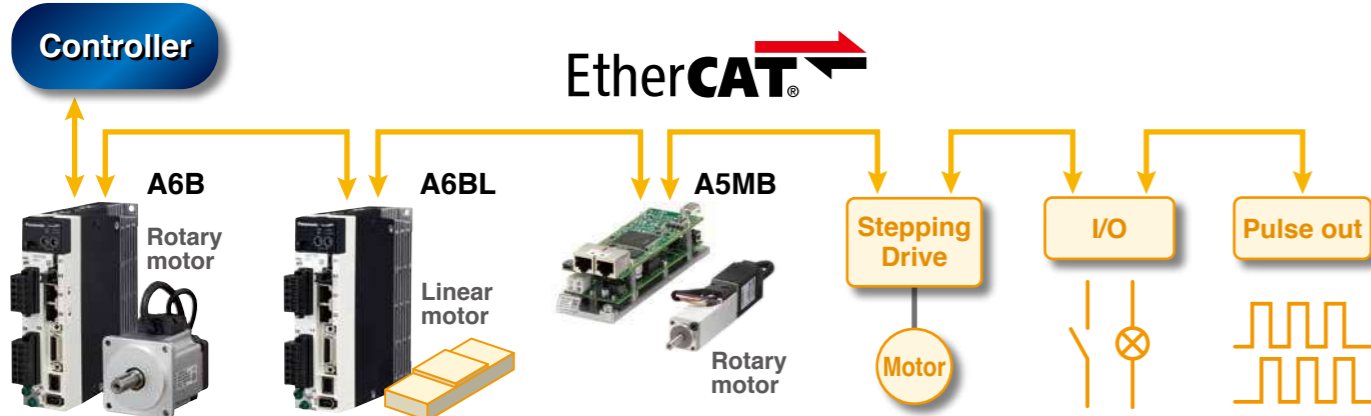

• EtherCAT specification for A6B series

Device profile	CoE (CANOpen over EtherCAT)
Control mode	csp, pp, hm, csv, cst, pv, tq
hm method (homing mode)	1 to 14, 17 to 30, 33, 34, 35, 37
Synchronized mode	DC (Synch.), SM2 (Synch.), FreeRun (Non-synch.)
Supported cycle time	125 μs, 250 μs, 500 μs, 1 ms, 2 ms, 4 ms

Drive list

Drive power supply	Motor rated output													
	50 W	100 W	200 W	400 W	750 W	1 kW	1.5 kW	2 kW	3 kW	4 kW to 5 kW	7.5 kW	11 kW to 15 kW	22 kW	
1-phase 100 to 120 VAC	Frame	A		B	C									
	Driver Part No.	MADL01B☆	MADL11B☆	MBDL21B☆	MCDL31B☆									
1 or 3-phase 200 to 240 VAC	Frame	A		A	B	C	D	D						
	Driver Part No.	MADL05B☆		MADL15B☆	MBDL25B☆	MCDL35B☆	MDDL45B☆	MDDL55B☆						
3-phase 200 to 230 VAC	Frame								E	F	F	G	H	H
	Driver Part No.								MEDL83B☆	MFDL A3B☆	MFDL B3B☆	MGDLT C3BF	MHDLT E3BF	MHDLT F3BF
3-phase 380 to 480 VAC (Under development)	Frame					D	D	E	F	F	G	H	H	H
	Driver Part No.					MDDL54BF	MDDL64BF	MEDL84BF	MFDL A4BF	MFDL B4BF	MGDLT C4BF	MHDLT E4BF	MHDLT F4BF	

• Because there is the case that is different from the part number in the table by the motor, please check the combination in the catalog of the A6 series always.

• □ : Drivers specification..... N : Without safety function T : With safety function
 ☆ : Drivers specification..... E : For rotary motor (standard) F : For rotary motor (multifunction)
 L : For linear/DD motor (standard) M : For linear/DD motor (multifunction)*

* 400 V specification, G frame and H frame are only multi-function type

Compliance



Drive appearance

A6B size A

* This photo shows multi-functional type. Standard type does not have X3 and X5 connectors.

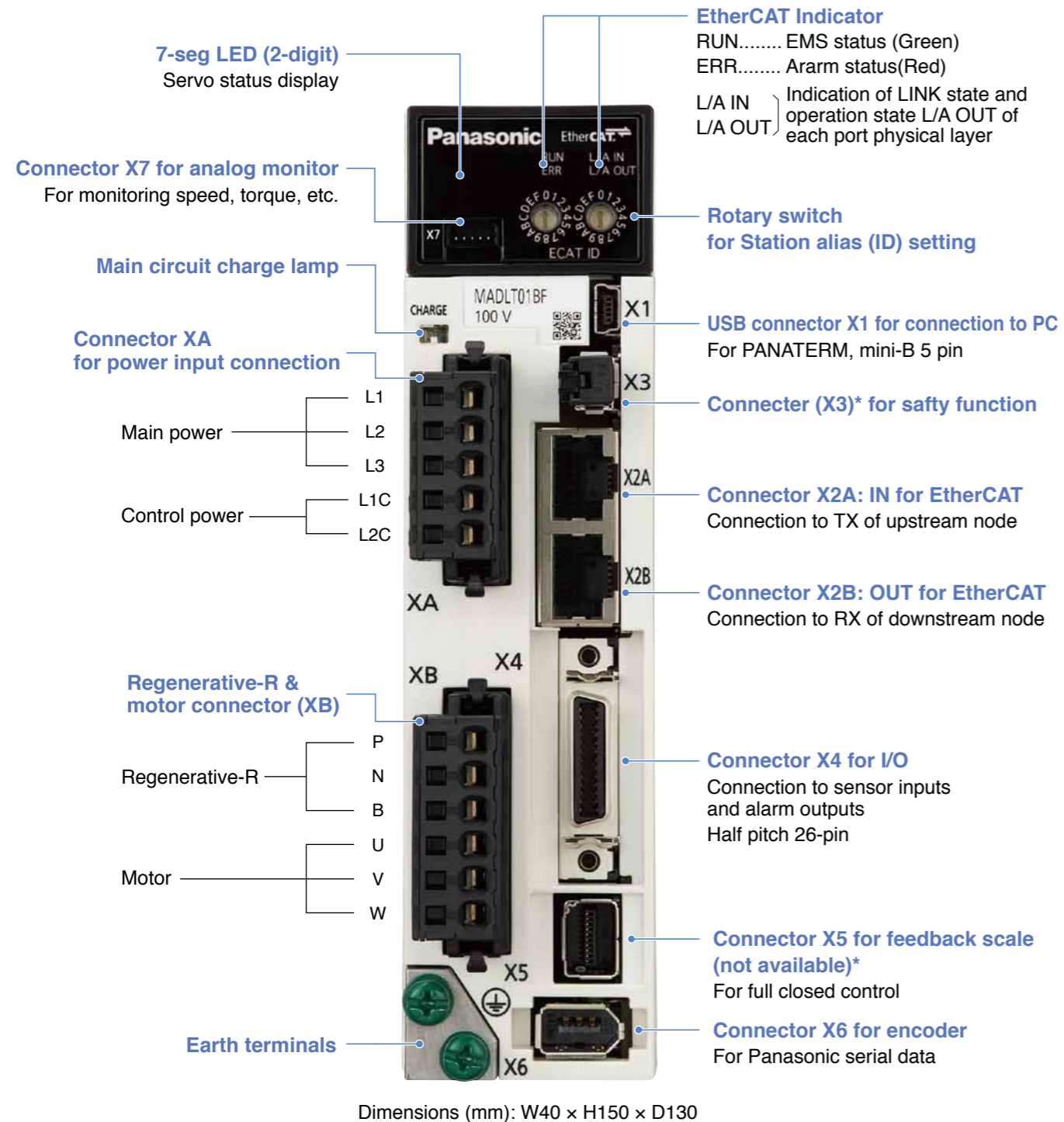

Low voltage small servo MINAS A5MB (DC24 V/48 V 10 W to 30 W)

• This product is not A6B, but A5B series for specific customers. For more details, refer to the specifications.

Drive appearance

A5MB

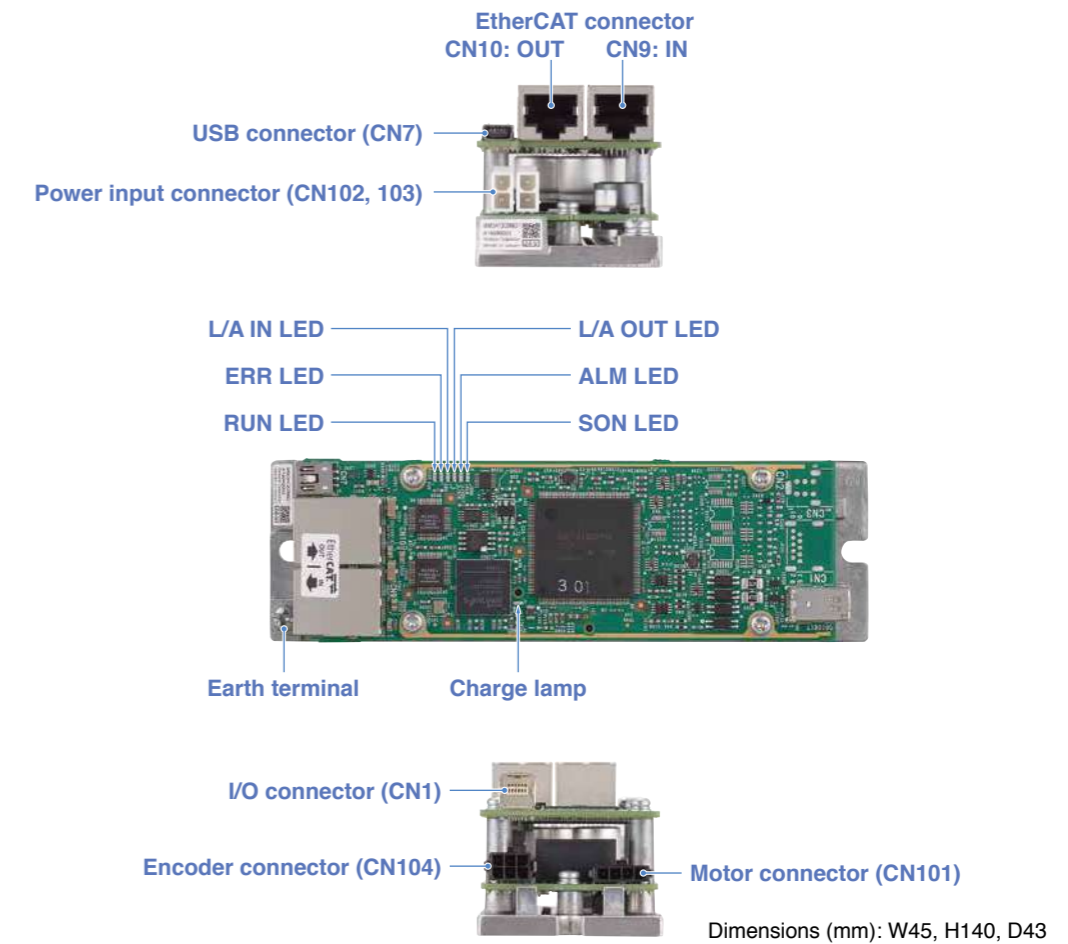

List of drivers

Driver power		Rated output of motor		
		10 W	20 W	30 W
DC 24 V	Frame symbol	M		
	Driver model number	MMDHT2C09BD1		
DC 48 V	Frame symbol	M		
	Driver model number	MMDHT2B09BD1		

• Depending on the motor series, there may be a combination different from the model number in the table, so be sure to check the specifications.

- A single FP7 Motion Control Unit can control 64 axes of MINAS A5B, A6B and 32 virtual axes.
- Up to 32 synchronous groups (32 groups of 2 axes to 2 groups of 32 axes)
- Control system: Cyclic position control
- Equipped with SD memory card. Communications log can be analyzed at startup which makes debugging easy.
- Through use of Web server function on FP7 CPU unit, remote monitoring is possible of things such as torque, speed and position of the motor.



Specification

Motion Control Unit

Product name	Number of axis		Part No.
	Real axis	Virtual axis	
Motion Control Unit EtherCAT type	16	8	AFP7MC16EC
	32	16	AFP7MC32EC
	64	32	AFP7MC64EC

Motion Control Setting Tool

Product name	Description	Part No.
Motion control setting tool Control Motion Integrator	Windows version. Downloadable free of charge from our website. Please purchase Key unit separately.	AFPSMTEN
Control Motion Integrator Key unit	License key for Control Motion Integrator. 1 license. For USB port.	AFPSMTKEY

Control Motion Integrator facilitates setting of parameters such as the unit's motion control parameter.



System Configuration

A single FP7 Motion Control Unit can control 64 axes of MINAS A5B, A6B and 32 virtual axes. Through use of Web server function on FP7 CPU unit, remote monitoring is possible of things such as torque, speed and position of the motor.

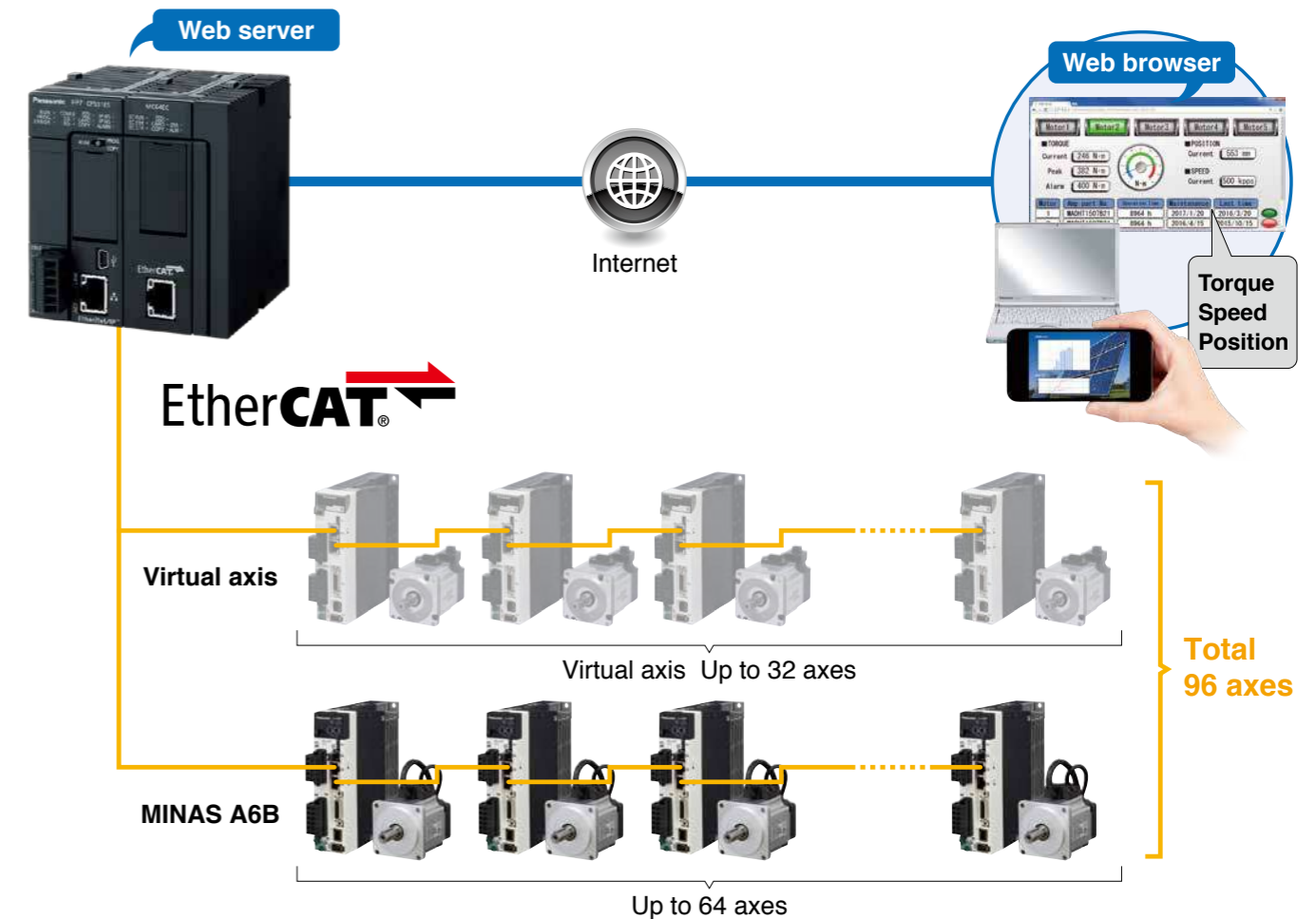

Application Sample

- Semiconductor manufacturing system
- LCD/FPD manufacturing device
- Electronic component manufacturing device
- Industrial machine
- Food processing machine
- Automatic warehouse system
- Physical distribution conveyance system

EtherCAT® Product Family

Features

EtherCAT® Master Stack software, available for real-time OS as well as Windows

- Ready-to-run implementations for many embedded operating systems
- EC-Win: high performance Windows Real-time extension included to achieve up to 50 µsec cycle time on Windows!
- Use multiple CPU cores on Windows for distributed EtherCAT applications
- CPU architectures: x86, ARM, PowerPC, SH, MIPS
- Reliable and well proven in many customer applications worldwide. Market leading companies in the Semiconductor, Robotics, PLC/Motion, Measurement and other industries rely on this software.

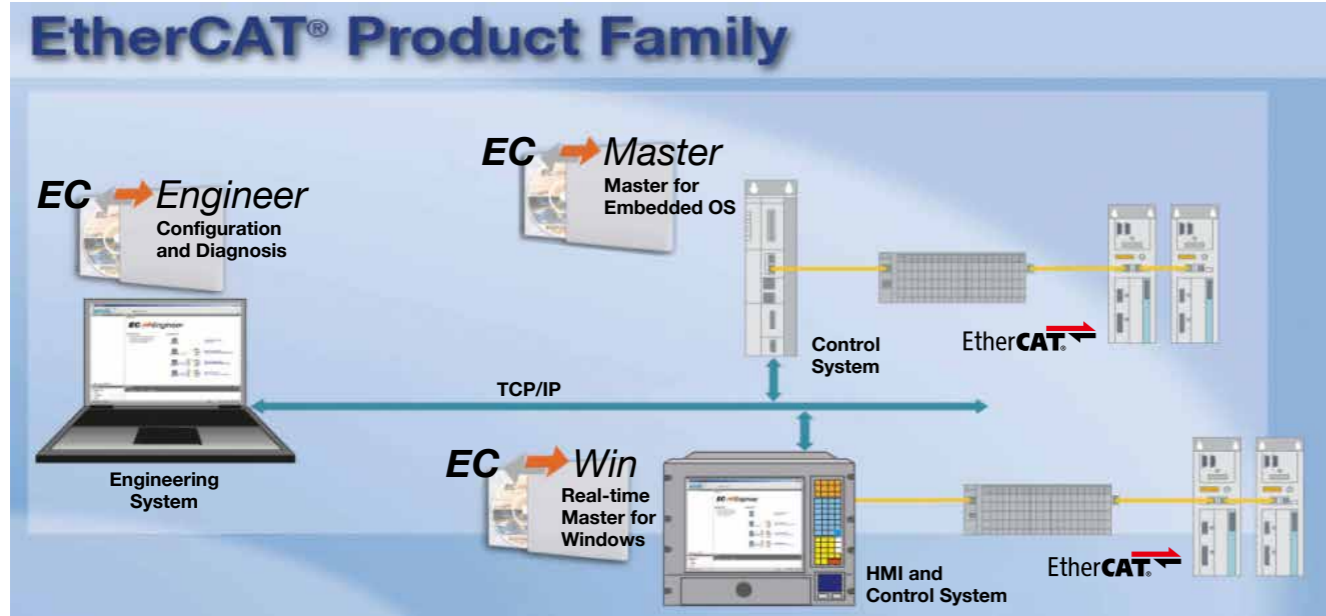

Specification

EC-Master according to ETG.1500 Master Classes Directive

Class A Core

- Compare network configuration
- Cyclic process data exchange
- All mailbox protocols: CoE, SoE, EoE, FoE, AoE, VoE
- Slave to slave communication
- **Distributed Clocks with master synchronization**

Class B Core

- Compare network configuration
- Cyclic process data exchange
- Mailbox protocol CoE
- Mailbox protocol SoE
- Mailbox protocol EoE
- Slave to slave communication

Feature Pack
Cable Redundancy

Feature Pack
Hot Connect

Feature Pack
Remote Access

Feature Pack
Superset ENI

Feature Pack
EoE Endpoint

Feature Pack
Master Obj. Dict.

The ETG (EtherCAT Technology Group) has defined EtherCAT Master Classes (ETG.1500) with a well defined set of Master functionalities.

2 Master Classes are defined:

- Class A: Standard EtherCAT Master Device
- Class B: Minimum EtherCAT Master Device

Additional functionality is described by Feature Packs. Acontis supports all Feature Packs in industry proven quality.

Application Sample

On Windows



Robotics



Semiconductor



CNC

On Embedded Systems



Industrial Automation



CNC



Test & Measurement

System Configuration

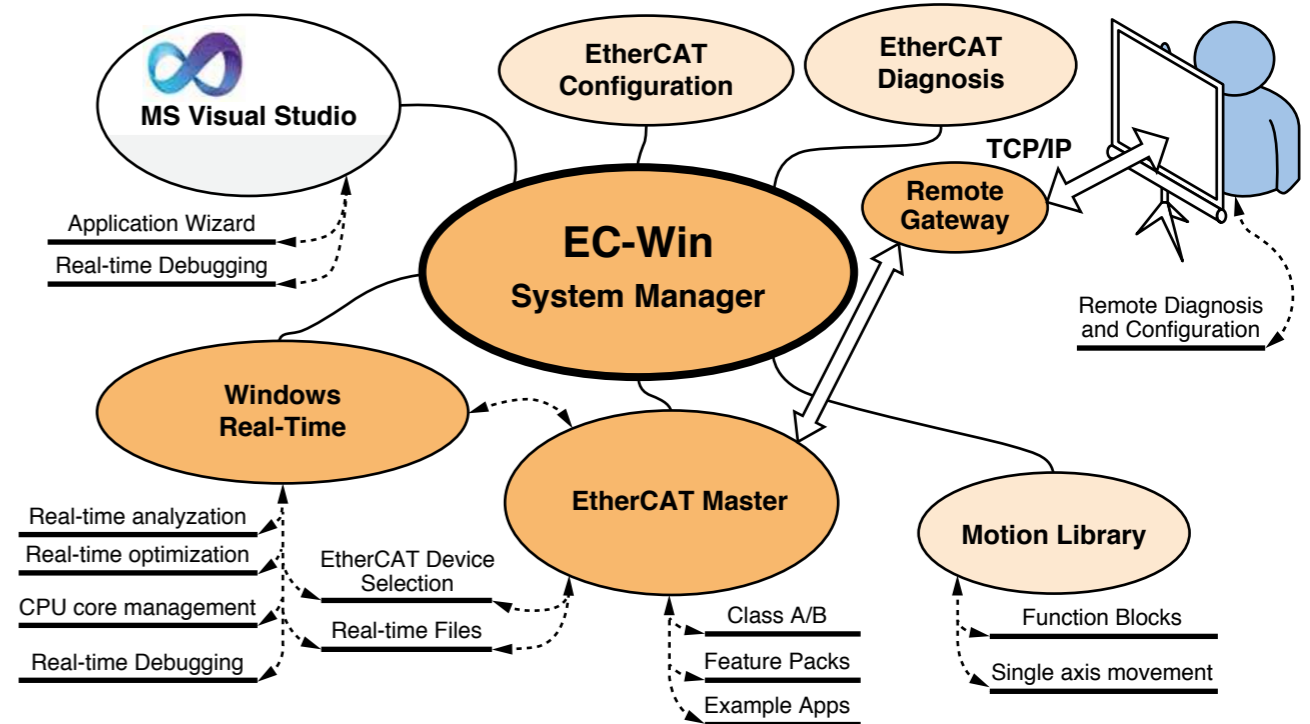

Sales area

- United States of America
- Japan • Taiwan • Korea • China

Language

- English
- Japanese

For more information

URL : <http://www.acontis.com/eng/index.php>

Contact: **acontis technologies GmbH**

Gartenstr. 46, 88212 Ravensburg /Germany

[E-mail: sales@acontis.com]

TEL: +49-751-560-3030

EtherCAT Master Controller

Talos-3012

Features

- Powered by ADLINK Softmotion
- Supports IEC 61131-3-compliant programming environment
- Minimal control cycle time as low as 250 μs
- Motion control of up to 64 axes and up to 10000 I/O points of control
- Supports EtherCAT COE, FOE as well as EOE protocols
- Code executable when host Windows system crashed
- Built-in SD socket for logging manufacturing data
- 3 user-defined indicators for CTR diagnostic
- Rugged, compact construction with fanless design at -20 °C to 60 °C



Specification

Model Name	Talos-3012	
Processor	Intel® Atom™ Processor E3845 1.9 GHz	
Controllable Motion Axis	64	
Controllable I/O Points	Up to 10000 points	
Control Cycle Time	250 μs (min.)	
Memory	RAM (Program & Data Memory)	2 GB DDR3
	Retain Memory	Configurable on SD card
	Storage (Date Usage)	16 GB SSD / SD Card
Field Bus Connectivity	1 for EtherCAT	
Ethernet Connectivity	1 GbE	
System Indicators	3 User-defined	
Programming Environment	CoDesys v3	
	IEC 61131-3-Compliant	
Supply Voltage	9-32 VDC wide-range DC input	
Environment Certificate	Vibration: 5 Grms, 5 - 500 Hz	
	Shock: 50 G, Half Sine 11 ms duration	
	EMC: EN 55011 class A	
Operating Temperature	-20 °C to 60 °C (-4 °F to 140 °F)	
Dimension	120 (W) × 100 (D) × 55 (H) mm (4.68" × 3.9" × 2.17")	

Software Support

- **IEC-61131-3 compliant Environment**
Support 5 different PLC Programming Languages

- **ADLINK Softmotion Inside**



- LD
- IL
- FBD
- ST
- SFC

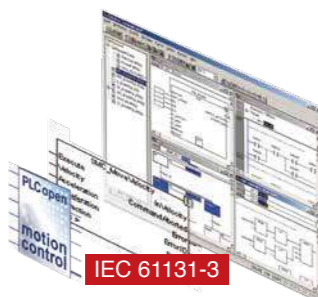

EtherCAT Slave System and Modules

EPS Series

Features

- EtherCAT COE, FOE, AOE protocols supported
- Communication quality diagnostic
- Slave module status monitoring
- Wide operation temperature range: -20 °C to 60 °C
- Compact size: 130 (L) × 110 (W) × 105 (H) mm
- SMART mechanical design for convenient installation
- IEC-61131 compliant



Specification

Model Name	EPS-9905 with EPS-6000
Installed Slots	5 (max.)
Protection Type	IP31
Hot Swap	Yes
Operating Temp.	-20 °C to 60 °C
Dimension (mm)	130 (L) × 110 (W) × 105 (H)
Weight (estimated)	< 1000 gram
Power Consumption	6.6 W
Supply Voltage	24 VDC (±10 %)
Environment Certificate	Vibration: 5 Grms, 5 - 500 Hz
	Shock: 50 G, Half Sine 11 ms duration
	EMC: EN 55011 class A

Model Name	EPS-1132	EPS-2032	EPS-2132
I/O Type	Digital Input	Digital Output	Digital Output
Channel	32	32	32
Hot Swap	Yes		
Input / Output Type	Sinking	Sourcing	Sinking
Input Range (by Voltage/Current)	IEC 61131-2 Type 1/3, 2.3 mA	-	-
Sampling Rate	<1 ms	4 kHz	4 kHz
Resolution	-	-	-
Output Current Capacity	-	300 mA / ch	300 mA / ch
Connector Type	Phoenix Contact DFMC		

Model Name	EPS-2308	EPS-3216	EPS-3032	EPS-3504	EPS-4008	EPS-7002
I/O Type	Relay Output	Analog Input	Analog Input	Thermal Input	Analog Output	Motion Control
Channel	8	16	32	4	8	2
Hot Swap	Yes					
Input / Output Type	Relay	Differential	Single-ended /Differential	RTD	Single-ended	Pulse-Train
Input Range (by Voltage/Current)	-	0 mA to 20 mA	+/- 10 V	RTD (PT100, 500, 1000)	± 10 V	PUS/DIR: 4 MHz ENC: 20 MHz
Sampling Rate	5 ms	100 kHz	100 kHz	5 - 20 Hz	100 kHz	-
Resolution	-	16 bit	16 bit	24 bit	16 bit	32 bit
Output Current Capacity	AC: 125 V @ 0.5 A DC: 30 V @ 2 A	-	-	-	5 mA	-
Connector Type	Phoenix Contact DFMC					SCSI VHDCI 68p

Sales area

- Worldwide response

Language

- English
- S/T Chinese

For more information

URL : <http://www.adlinktech.com/EtherCAT/index.php>

Contact: **ADLINK Technology, Inc.**

9F, No.166 Jian Yi Road, Zhonghe District, New Taipei City 235, Taiwan

[E-mail: service@adlinktech.com]

TEL: +886-2-8226-5877 FAX: +886-2-8226-5717

PCIe EtherCAT Master Motion Controller

PCIe-8338

Features

- PCI Express® x 1 compliant
- Up to 64-axis motion control & 10000 I/O point control via EtherCAT
- EtherCAT cycle times up to 250 μs
- Broad range of compatible EtherCAT slaves
- Dedicated emergency stop input
- 4CH isolated digital input/4CH isolated digital output
- 1CH pulsar input
- Point-table functions for contouring application
- Support for up to 16D linear interpolation, 3D circular and 3D spiral interpolation
- 8 program tasks downloadable for standalone application
- Card ID selection

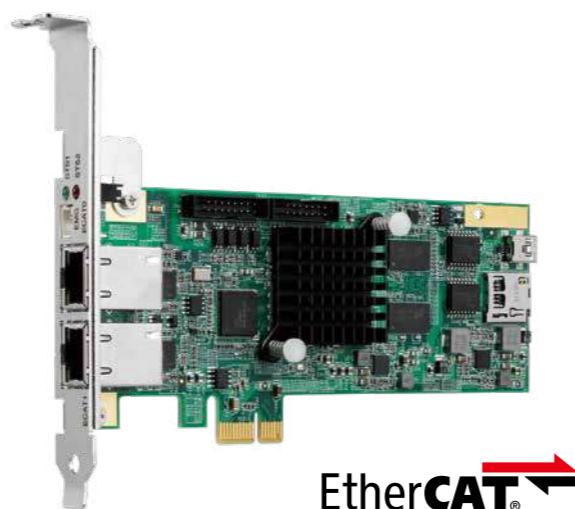

EtherCAT

Specification

Model Name	PCIe-8338
EtherCAT Cycle Time	1CH @ 250 μs / 500 μs / 1000 μs / 2000 μs
EtherCAT Motion	Up to 64 axes
EtherCAT I/O	Up to 10000 Points
Motion I/O Interface Signals	
Emergency Stop In	1CH
Isolated I/O Signals	
Digital Input	4CH (2CH configured as Pulsar Input)
Pulsar Input Mode	CW/CCW; 1x/2x/4x AB Phases
Pulsar Input Frequency	Up to 1 MHz
Digital Input Voltage	24 Vdc (typ.) / 5 Vdc for pulsar connection
Digital Input Type	Sourcing type
Digital Output	4CH, Isolated
Digital Output Voltage	24 V (typ.)
Digital Output Type	90 mA, NPN sinking type
General Specification	
Operating Temp	0 °C to +60 °C (32 °F to 140 °F)
Humidity	5 % to 95 %, non-condensing
Environmental Specification	
Safety compliance	CE/FCC, RoHS

EtherCAT Master Controller with 4CH GigE Vision Support

Talos-2000 Series

Features

- 6th Generation Intel® Core™ i7/i5/i3 Processor
- Up to 64-axis motion control & 10000 I/O point control via EtherCAT
- Up to 4CH Gigabit PoE (power over Ethernet)
- EtherCAT cycle time up to 250μs
- Broad AVL of EtherCAT slaves, PoE cameras
- Point-table functions enabling application contouring
- Support for up to 16D linear, 3D circular, and 3D spiral interpolation
- Easy installation and maintenance with flexible function extensions via Ethernet connection
- 4CH isolated digital input/4CH isolated digital output



Talos-2000 Series
EtherCAT-based Vision-integrated
Automation Control System

EtherCAT

Modbus

GIGEVISION

Intel IoT Solutions
Alliance
Partner

EtherCAT

Specification

Model Name	Talos-2000
CPU	Intel® Core™ i7-6700 Intel® Core™ i5-6500 Intel® Core™ i3-6100 Intel® Celeron® G3900
Chipset	Intel® H110 chipset
System Memory	Up to 32 GB DDR4 at 2133 MHz
EtherCAT Comm.	1 CH @ 250 μs (min. cycle time)
EtherCAT Motion	Up to 64 axes
EtherCAT I/O	Up to 10000 points
Camera Interface	4-CH Gigabit power over Ethernet IEEE 802.3af compliant, total max. power output 32 W
Display	2x DisplayPort with resolutions up to 4096 x 2160
USB	4x USB 2.0 ports, 4x USB 3.0 ports (internal USB 2.0 x1)
COM Ports	1x RS-232/422/485, 3x RS-232
Emergency Stop In	1CH
Digital Input	4 CH (2 CH configured as Pulsar Input)

Pulsar Input Mode	CW/CCW; 1x/2x/4x AB Phases
Pulsar Input Frequency	Up to 1 MHz
Digital Input Voltage	24 VDC (typ.) / 5 VDC for pulsar connection
Digital Input Type	Sourcing type
Digital Output	4 CH, Isolated
Digital Output Voltage	24 V (typ.)
Digital Output Type	90 mA, NPN sinking type
Power Supply	DC 24 V, AT mode
Operating Temp	0 °C to +55 °C (32 °F to 131 °F)
Humidity	0 % to 90 %
Dimensions	232(W) x 181 (D) x 86.3 (H) mm
Power Consumption	Up to 160 W
Storage	One 2.5" SATA interface
Random Vibration	Operating 0.5 Grms, 5-500 Hz, 3 axes w/ HDD
Safety compliance	CE/FCC, UL, RoHS

Sales area

- Worldwide response

Language

- English
- S/T Chinese

For more information

URL : <http://www.adlinktech.com/EtherCAT/index.php>

Contact: **ADLINK Technology, Inc.**

9F, No.166 Jian Yi Road, Zhonghe District, New Taipei City 235, Taiwan

[E-mail: service@adlinktech.com]

TEL: +886-2-8226-5877 FAX: +886-2-8226-5717

Intelligent EtherCAT® Master Board

Low CPU load EtherCAT® Master Communication

Features

Low CPU load EtherCAT® Master Communication

EtherCAT® environment is enabled typically by implementing the master stack on Ethernet hardware. Advanet provides EtherCAT® master communications on-board by implementing the Xilinx Zynq® with ARM® Cortex®-A9 on a board to minimize the impact for the host CPU as bus master.

Secure Cable Redundancy

The redundant cable configuration adopting ring topology which recovers the communication cable failure in the EtherCAT® system allows the communications to reach any branch even in case of cable fracturing happened at any point.

Hot Connect Responds to Unexpected Replacement

The protocol of the EtherCAT® system utilizing a hot connect capability provides flexible and responsive functionalities to change the system configuration which allows you to connect/disconnect or reconfigure any part of the network “on-the-fly”.

Specification

	A3pci1571	AdEXP1572	AdXMC1573
Form Factor	3U CompactPCI®	PCI Express®	XMC
CPU	ARM® Cortex®-A9 Dual-Core (Xilinx: Included in Zynq®-7010)		
Main Memory	DDR3 SDRAM 256 MB		
Boot ROM1	SPI-FLASH 16 MB		
Boot ROM2	microSD (Spare)		
Shared Memory	256 KB (Included in Zynq® PL)		
EtherCAT®	Master Class A Compliant / Redundant Cable, Hot Connect / Controllable Cycle 100 µs to 10 ms		
Front IO	2× EtherCAT® ports, 100BASE-TX, RJ45 Connector		
Bus Interface	PCI Local Bus Specification Revision 2.2 Compliant PCIMG 2.0 R3.0 CompactPCI® Specification Compliant PCIMG 2.1 R2.0 CompactPCI® Hot Swap Specification Compliant	PCI Express Base Specification Revision 1.0a Compliant PCI Express Card Electromechanical Specification Revision 1.1 Compliant	IEEE1386.1-2001 ANSI/VITA42.3-2006 PCI Express Base Specification Revision 1.0a Compliant
Power Supply	DC5 V ±5 %	DC12 V ±8 % DC3.3 V ±9 %	DC12 V ±5 % DC3.3 V ±0.3 V
Dimension	160 mm × 100 mm (3U Size CompactPCI® Bus 1 Slot width)	167.5 mm × 68.75 mm (Low Profile or Standard Height)	74 mm × 139 mm
Operating Environment	Operating Temperature Range : 0 °C to 55 °C Operating Humidity Range : 35 % to 80 %RH (non-condensing) Non-Operating Temperature Range : -10 °C to 70 °C Non-Operating Humidity Range : Under 90 %RH (non-condensing)		
Device Driver	Wind River® VxWorks® 6.9.x, Microsoft® Windows® 7 (Driver Implementation Document is available)		

System Configuration

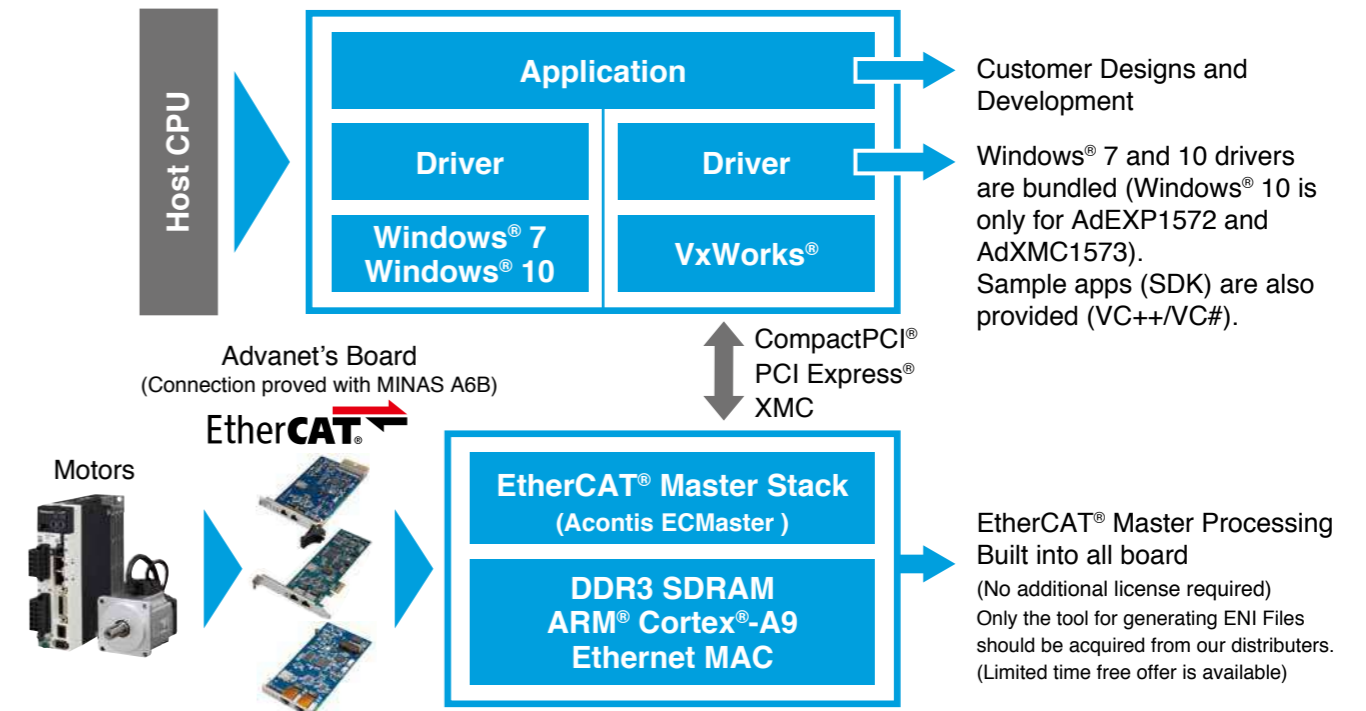

Features of Advanet EtherCAT Slave

- Simultaneous measurement of 24ch in 1 slave
- Connectable 4-wire Pt100 or JPt100
- Temperature conversion on module
- Measurement overall precision at ±0.1 °C (*Measurement range: -20 °C to 80 °C)

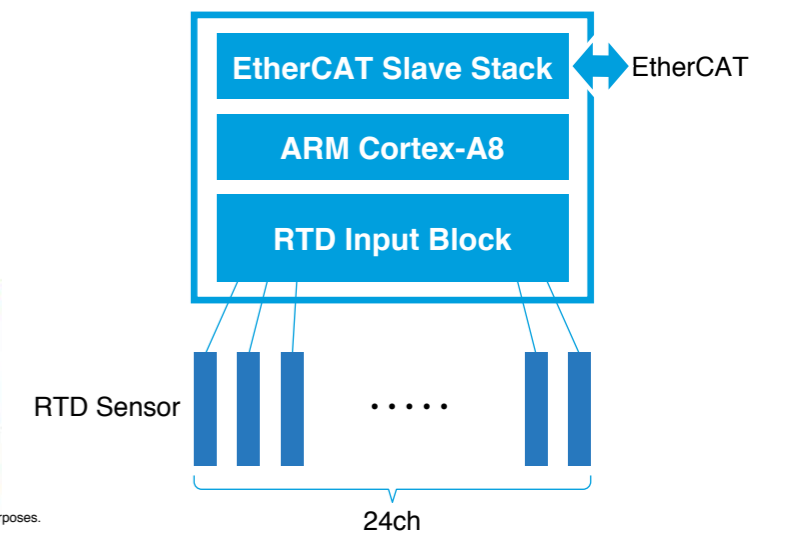
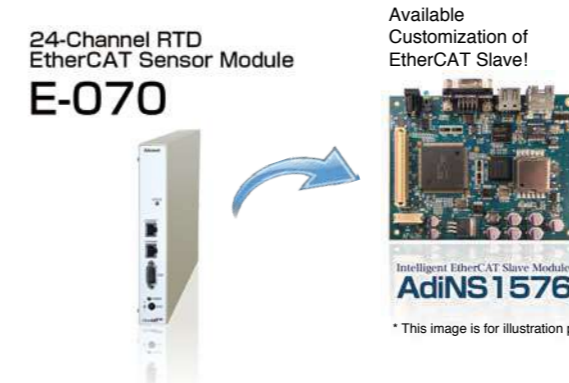

Sales area

• Worldwide response except for some areas.
Please contact the following address for details.

Language

- Japanese
- English

For more information

URL : <https://www.advanet.co.jp/ethercat/>

Contact: **Advanet Inc.**
616-4 Tanaka, Kita-Ku, Okayama 700-0951, Japan

[E-mail: sales@advanet.jp]
TEL: 086-245-2861
URL : <https://www.advanet.co.jp>

2-Port EtherCAT PCI/PCle Motion Control Master Card

PCI-1203/PCIE-1203/PCIE-1203L

Features

- Dual EtherCAT ports for high-performance of Motion and I/O applications
- Up to 64 axes support for motion control
- Motion cycle time: 32 axes = 500 μs; 64 axes = 1 ms; I/O cycle time=200 μs
- Supports ready-to-use API for rapid application development
- Multi-axis synchronous motion
- Trace logger for fast error diagnostics
- Easy to wire, saving wiring working-hour



Specification

Item	Description			
	EtherCAT Master	PCI-1203	PCIE-1203	PCIE-1203L
Port		32	64	
Motion Ring Cycle Time		500 μs	500 μs @ 32 Axes, 1000 μs @ 64 Axes	
I/O Ring Cycle Time		200 μs		
Motion Control				
Single-Axis Motion	JOG Move Position/Velocity/Time Planning Position/Torque Limit			
Motion Trajectory Planning	2/3-axis Line Interpolation; 1~8 axis Direct Interpolation 2/3-axis Circular Interpolation Support 6 Path Table (size: 7k points / table)		N/A	
Master & Slave Synchronized Motion	Gantry E-Gear E-CAM Tangential Following Position Latch		N/A	
Software				
Utility	Common Motion Utility			
Driver	Windows XP/7/8/10			
Example	VC, VB, VB.NET, C#, BCB, LabVIEW			

Application Sample

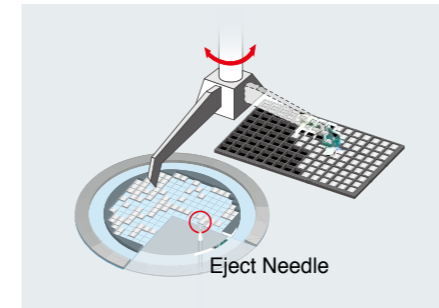

Torque Limit Table

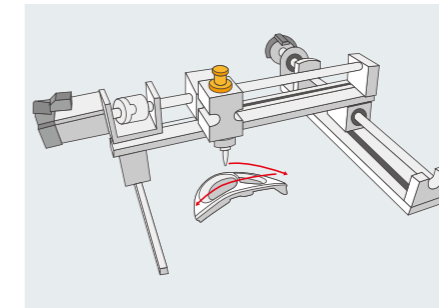

3D Arc Interpolation

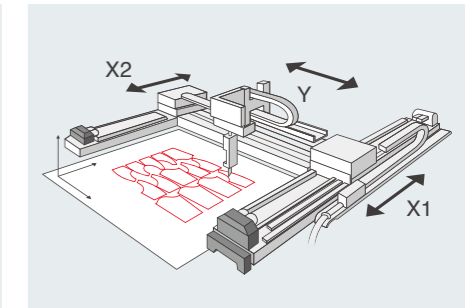

Gantry

System Configuration

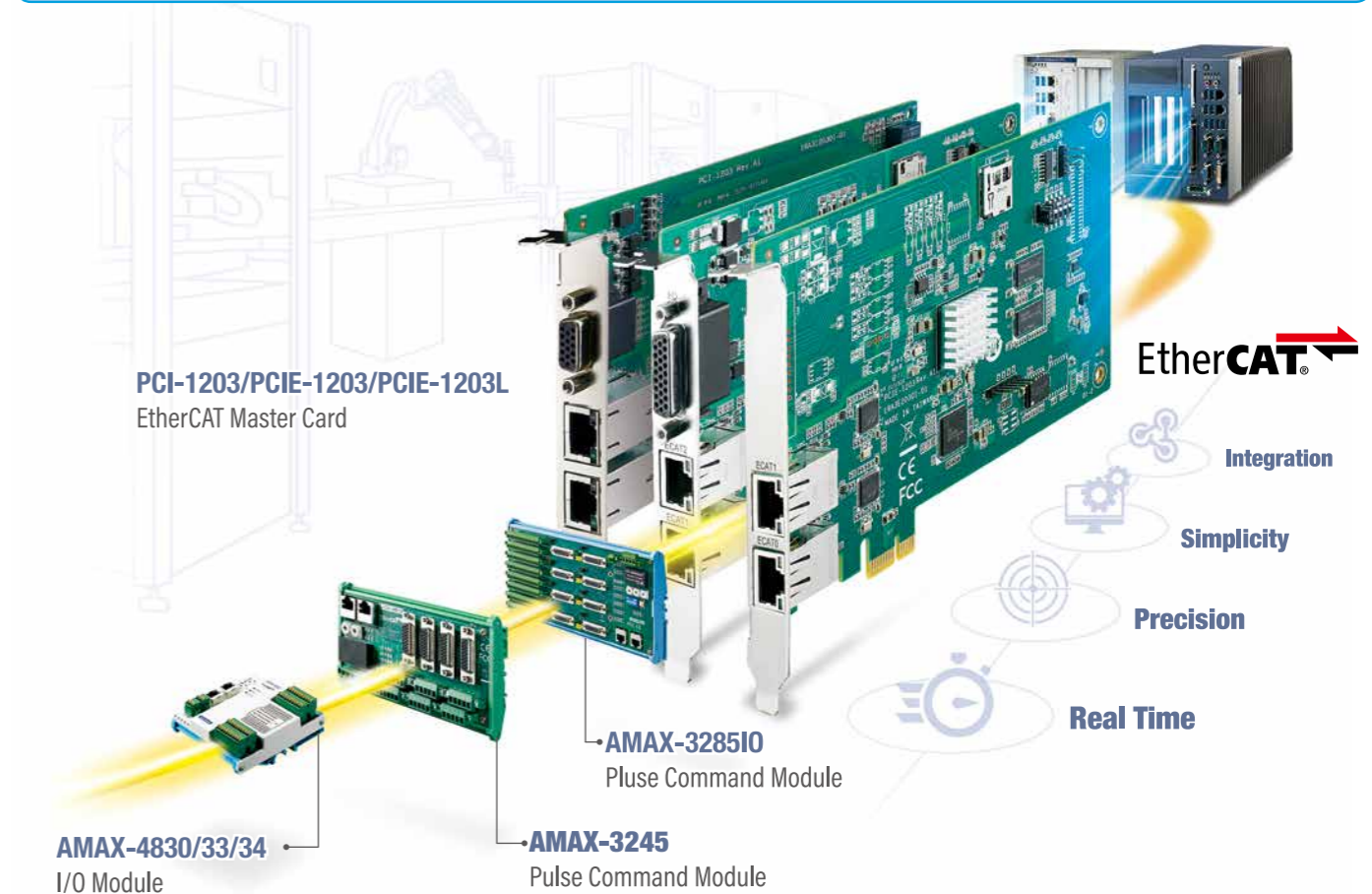

Sales area

- Worldwide response
- Please contact the following address for details.

Language

- Chinese
- English

For more information

URL : http://www.advantech.com/products/machine-automation/sub_machine_automation

Contact: **Advantech Co., Ltd.**

No. 1, Alley 20, Lane 26, Rueiguang Road, Neihu District, Taipei 11491, Taiwan

[E-mail: buy@advantech.com.tw]

TEL: +886-2-2792-7818 FAX: +886-2-2794-7327

EtherCAT master

EC Master

“All-in-one Controller”, based on the Industrial PC equipped with EtherCAT master stack

Features

All-in-one controller can execute SCADA, synchronous motion control and image processing just by itself.

- International standard (IEC 61131-3) compliant software PLC
- PLCopen compliant positioning/synchronous motion control software
- OpenCV, OpenVX compliant image processing engine (option)
- SCADA-based HMI software

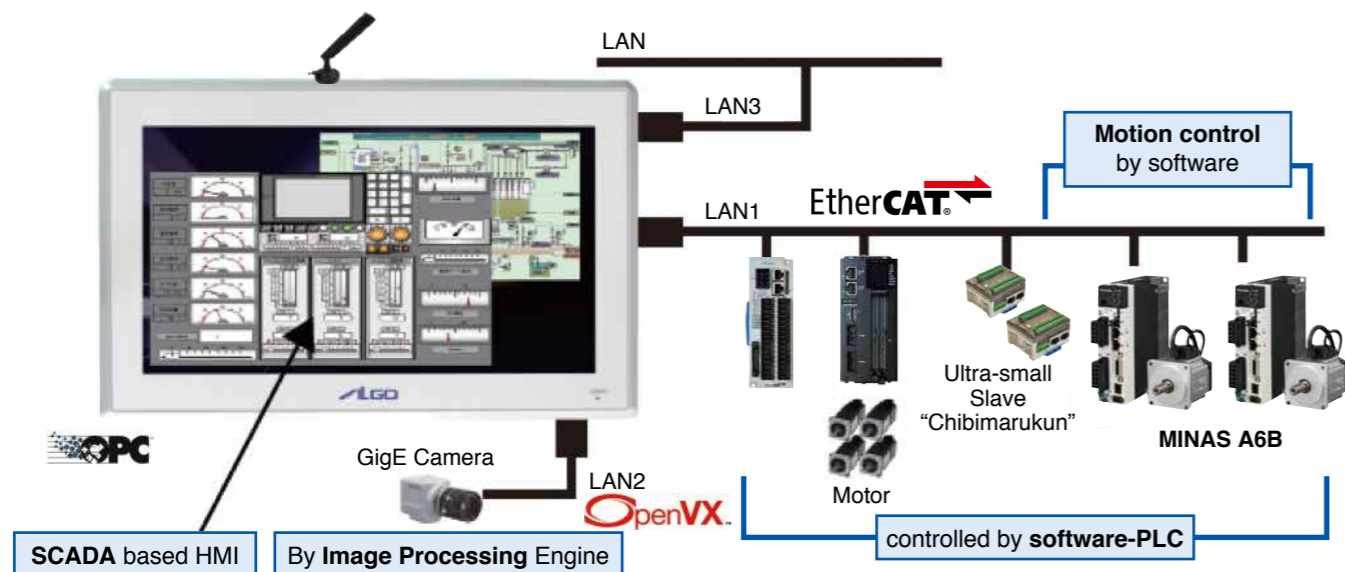

Specification

- Intel® high-performance processor, Atom E3845 Quad Core 1.91GHz
- Real time OS (INtime). High-speed 28000 steps/50 μs processing.
- Windows10 IoT Enterprise allows effective utilization of various software
- Top-class ultra-thin compact design and lower power consumption allow for installing in small space for new, expanded use. Free switch off. Multi-touch panel. Multilingual
- Fanless, diskless, completely spindleless. 2 storage, mini m-SATA, slots. support.

UPS equipped standardly

GPIO, 6 IN / 4 OUT, equipped standardly

LTE equipped, can access directly to Cloud

Suitable for dedicated controller

Application Sample



ALGOSYSTEM's All-in-one Controller had replaced PLC and has been adopted as de facto standard controller of the minimalfab for processing a half-inch wafer to make semiconductors in high-mix low-volume production. Minimalfab is the national project carried out by the National Institute of Advanced Industrial Science and Technology (AIST). The key to adoption of the All-in-one Controller is its high performance and space saving, it can support multi-vendors' products and encrypt, it can be programmed by either C or software PLC compliant to IEC61131-3 Standard which provides 5 languages: LD, FBD, IL, ST and SFC.



EtherCAT slaves

Features/ Specification

Digital input/output (NPN/PNP)

- 16-point input unit
- 16-point output unit
- 32-point input unit
- 32-point output unit
- 16-point input/16-point output unit

<“Chibimarukun” series>

e-CON connector

- 8-point input unit
- 8-point output unit
- 4-point input/4-point output unit

MIL connector terminal block

- 16-point input unit
- 16-point output unit
- 8-point input/8-point output unit

Relay output (terminal block)

- 4-point relay output unit

Analog input/output

- 4ch analog input unit
- 4ch analog output unit

IO-Link, Modbus, 4ch SIO Gateway

to EtherCAT. * IO-Link, Modbus, Serially controlled devices such as RS-232C and RS-485 devices are converted to EtherCAT. EtherCAT can be installed without putting old assets to waste.

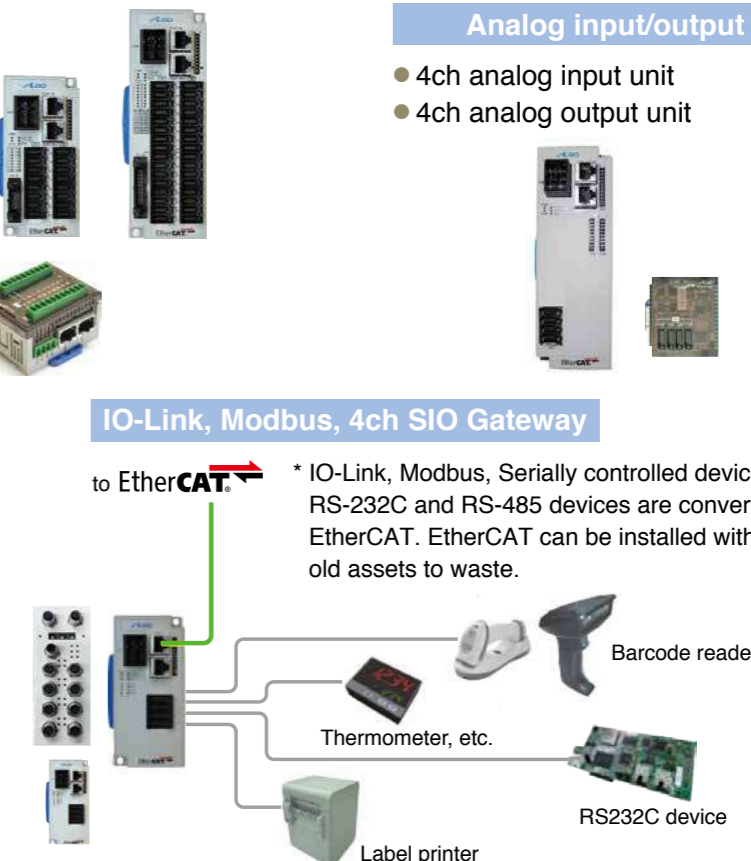

Motion controller

- Up to 4-axis control
- Execute from high-order PC, etc. via restricted EtherCAT connection



Encoder input

- Line receiver input
- Open collector input



Contract-based Development



Interface board example

Sales area

- Japan
- United States of America
- Korea
- China

Language

- Japanese
- English

For more information

URL : <http://www.algosystem.co.jp/>

Contact: **ALGO SYSTEM Co.,Ltd.**

656 Kobirao Mihara-ku, Sakai, Osaka, 587-0021 Japan

[E-mail: itami@algosystem.co.jp]

TEL: +81-72-362-5067 FAX: +81-72-362-4856

Software PLC/ NC/ CNC

TwinCAT 3

Features

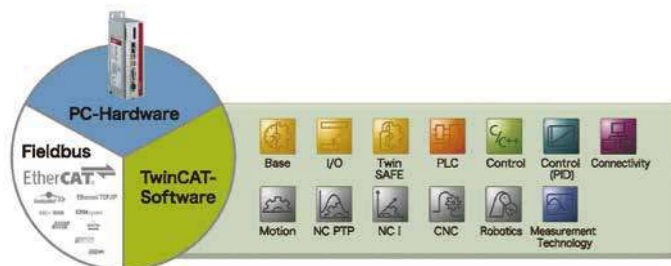

PC base automated control

- One tool for PLC, motion and HMI
- Scalable performance and lower cost by using general-purpose CPU
- Fusion of automation and IT

Real-time control system in PC base system Software PLC/ NC/ CNC TwinCAT® 3

1) IEC 61131-3 3rd edition

Integration of Microsoft Visual Studio
Support for IEC61131-3 (IL, ST, FBD, LD, SFC) +CFC and object-oriented extension of the 3rd edition

2) Development environment

Support for C/C++, real-time environment in MATLAB®/ Simulink®, programming in .NET/C#.

3) Link to MATLAB®/Simulink®

Link to MATLAB®/Simulink® optimizes development and simulation

4) Multi-core CPU support

Impressive real-time performance and high level integration by assigning HMI, PLC, NC, CNC tasks to individual CPU cores..

Supports simultaneous editing of IEC61131 and C/C++ language

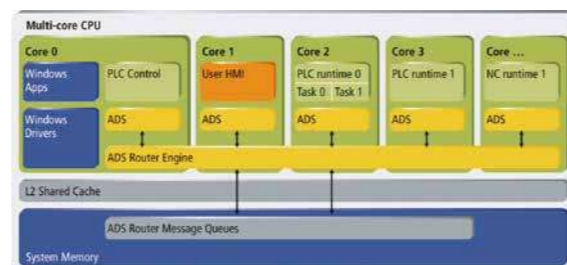
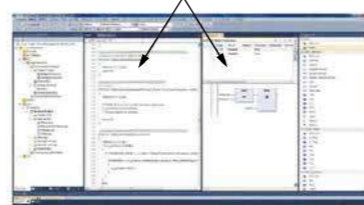

System Configuration



TwinCAT CNC



CX5100 series controller + EtherCAT Terminals

- PC base controller with TwinCAT supporting multi-core maximizes EtherCAT performance
- Compact controller on DIN rail (CX5100 series)
- TwinCAT PLC processes minimum 50 μs real-time task, and controls motion system in minimum 125 μs

EtherCAT

MINAS A6B

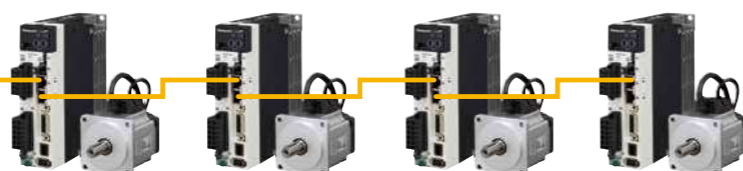

Industrial PC

C6015 / C6030

Features

The Ultra Compact IPC Generation



C6015: Ultra small



C6030: Ultra powerful

Specification

Technical data	C6015	C6030
Processor	Intel® Atom™ x7-E3950, 1.6 GHz, 4 cores	Intel® Core™ i7-7700, 3.6 GHz, 4 cores
Internal main memory	8 GB DDR4L RAM	32 GB DDR4 RAM
Flash memory	30 GB M.2 SSD, 3D flash, expandable to 60 GB	40 GB M.2 SSD, 3D flash, expandable to 160 GB
Interfaces	USB 3.0 × 2/ DisplayPort × 1 / Gbit Ethernet Port × 2	USB 3.0 × 4/ DisplayPort × 2 / Gbit Ethernet Port × 4
Operating system	Windows 10 IoT Enterprise	
Power supply	24 V DC	
Dimensions (W × H × D)	compact dimensions (W × H × D) 82 mm × 82 mm × 40 mm (3.2" × 3.2" × 1.6") without mounting plate	compact dimensions (W × H × D) 129 mm × 133 mm × 78.6 mm (5.1" × 5.2" × 3.1") without mounting plate
Operating/storage temperature	operating temperature 0 °C to 50 °C	operating temperature 0 °C to 55 °C
Protection class	IP20	

Sales areas

Local support: Japan, China, Korea, south-eastern Asia, Europe, the Americas, etc. More than 75 countries

For more information

URL : www.beckhoff.com

Beckhoff worldwide : <https://www.beckhoff.com/english/beckhoff/world.htm>

Contact: **Beckhoff Automation GmbH&Co.KG**

[E-mail: info@beckhoff.com]

TEL: +49 5246 963-0

CODESYS
IEC 61131-3 Engineering / Software PLC / Motion / CNC / HMI

Features



CODESYS



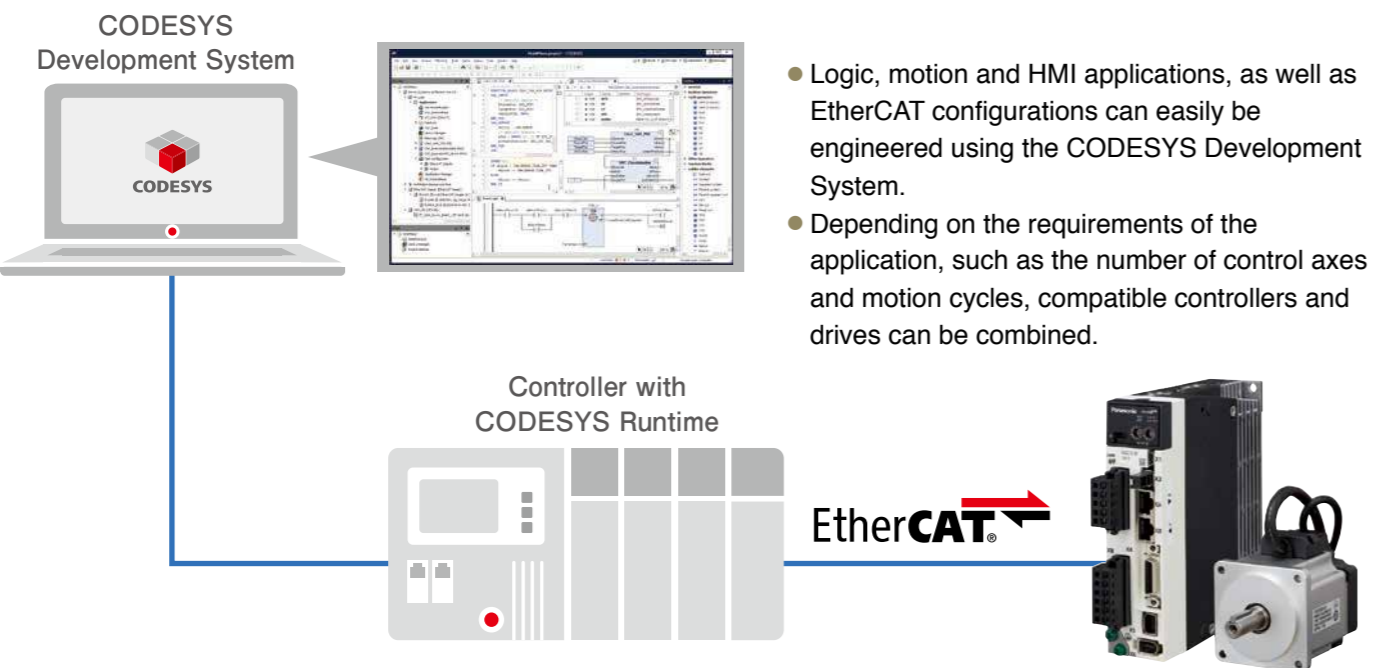

CODESYS is the number one hardware-independent IEC 61131-3 software suite for the automation industry. The tool is used to develop application software for compatible hardware and software PLCs, professional HMI screens and motion control projects with CNC or robotics for example using EtherCAT. More than 400 device manufacturers worldwide use the tool to engineer their intelligent devices. Well over one million such devices are used to operate different industrial machines and plants every year.

System Configuration



Specification

Fully integrated: Realize PLC, Motion and HMI functions on a single device with CODESYS.

-  **PLC Programming**
IEC 61131-3-compliant, all languages (ST, Ladder, FBD, SFC, CFC) supported, plus real object oriented programming
-  **SoftMotion**
For single axis control, electric cam and gear, using the integrated FBs (PLCopen Motion Control part 1, 2 compliant)
-  **SoftMotion CNC+Robotics**
For complex coordinated motion control tasks such as robotics/CNC applications using the integrated FBs (PLCopen Motion Control part 4); linear / circular interpolation, various kinematics, G-code programming, comfortable axis configuration etc.
-  **HMI, Visualization**
Integrated visualization editor in the CODESYS Development System: easy creation of modern operation screens and linking to IEC 61131-3 variables; display of the generated screens on IPCs, on panel PLCs with CODESYS TargetVisu, on standard Web browsers with CODESYS WebVisu (via HTML5) or in the engineering tool
-  **Fieldbus**
Integrated fieldbus configurators and protocol stacks as CODESYS libraries seamlessly integrated in the CODESYS Development System for numerous fieldbus systems, such as EtherCAT, PROFINET, Ethernet/IP

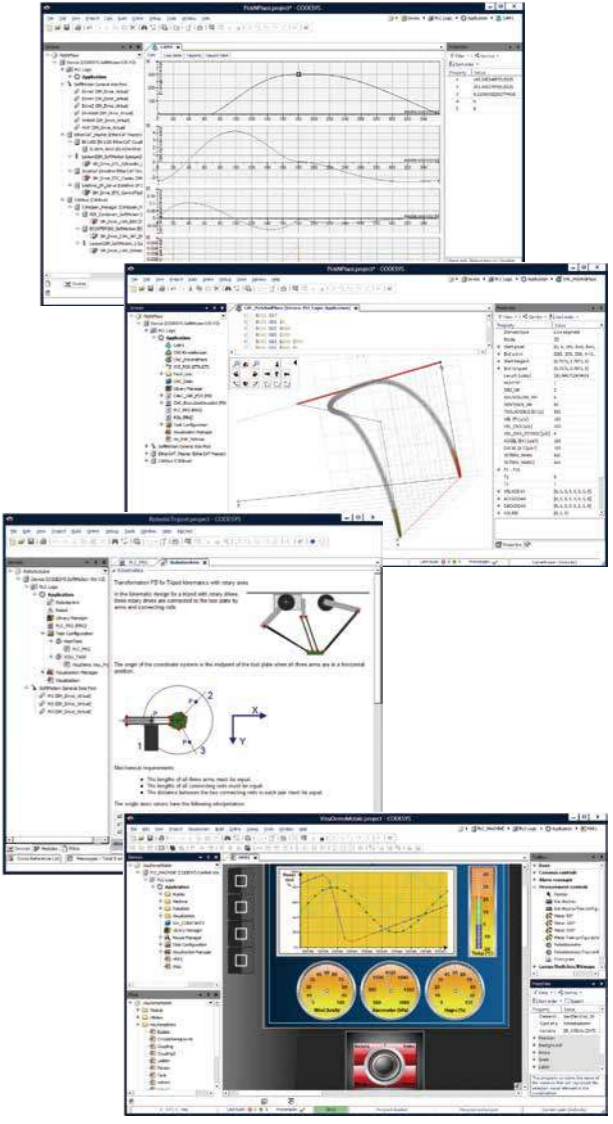

EtherCAT



Sales area

- Japan
- Russia
- Italy
- Germany
- EU
- France
- China
- United Kingdom
- Netherlands
- Korea

Language

- Japanese
- German
- Spanish
- English
- Italian
- French
- Chinese
- Russian

For more information

URL : <https://www.codesys.com>

Contact: **CODESYS Group**
Memminger Str. 151, 87439 Kempten, Germany

[E-mail: info@codesys.com]
TEL: +49-831-54031-0 FAX: -50

IEC61131-3 Standard Industrial IoT Controller

CONPROSYS PAC(Programmable Automation Controller) Solution

Features

Configurable Type



EtherCAT Module
CPS-PCS341EC-DS1-1201
Modbus Module
CPS-PCS341MB-DS1-1201

Integrated Type



EtherCAT Module
CPS-PC341EC1-9201
Modbus Module
CPS-PC341MB-ADSC1-9201

IEC 61131-3 Standard CODESYS Programming

Equipped with the PLC engine "CODESYS," which continues to be used more and more commonly in the global market. Applications can be developed in programming languages, such as Ladder/SFC/Function Block etc., that comply with international standard IEC 61131-3.

Integrated Development Environment Provided free of charge

An integrated development environment for developing applications is provided free of charge. This makes it possible to seamlessly perform all the required development such as control logic and field bus I/O.

Supported integrated development environment: V3.5 SP7 Patch 2 or later

Supported languages: LD / SFC / FBD / ST / IL / CFC



Equipped with Field-Bus Master Functions EtherCAT / Modbus Supported

Equipped with an open-field network EtherCAT / Modbus master function. In the CODESYS integrated development environment, fieldbus I/O can be directly assigned to variables in the same manner as the built-in I/O and the stack I/O.

SCADA / MES / ERP Linking Built-in OPC-UA Server

OPC-UA is essential for the M2M communication. The controller has a built-in server function. This enables the safe and stable exchange of data with SCADA software and MES/ERP systems.

Equipped with a Web HMI Engine Web Monitor Function

The controller has a built-in web server function and tools for creating screens for use on the web. This makes it possible to easily view equipment information without using a cloud server or a similar device.



Specification

Item		EtherCAT Module	Modbus Module
CODESYS Function	Version	V3.5 SP7 Patch2 or later version	
	Languages	LD, SFC, FBD, ST, IL, CFC (IEC61131-3 compliant)	
	Field Bus	EtherCAT Master, Modbus TCP Slave	Modbus TCP Master / Slave
Program size	Communication Protocol	OPC-UA Server	
	ROM Size	1 MB	
	Maximum Steps	250 K Steps	
CPU basic performance	Basic Instruction Execution Speed (LD)	1.6 ns	
	Application Instruction Execution Speed (ST)	5.8 ns	
	Variance	Maximum 300 μs	
	Scan Time	74 μs (20000 steps)	
EtherCAT Performance	Input Processing Time (LD)	144 ns	-
	Output Processing Time (ST)	138 ns	-
	Scan time	166 μs (64 Input and 64 Outputs)	-

Application Sample

- Electronic Component Mounting Machine
- Industrial Robot / Arm
- Semiconductor Manufacturing Equipment
- Machine Tools and Processing Machine
- LCD/FPD Manufacturing Equipment

System Configuration

SCADA / MES / ERP Linking OPC-UA



Big Data Analysis Cloud Service



Web Monitoring Web HMI

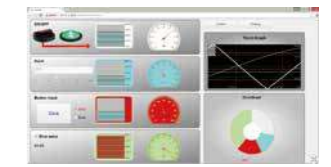

Host Network

CONPROSYS PAC

IEC 61131-3 standard
PLC Programming System
LD / SFC / FBD / ST / IL / CFC



EtherCAT

Stack I/O

Motion Control, Switch On/Off, Flow Rate, Pressure, Temperature, Voltage, Current

MINAS A6B



Sales area

- Japan
- China
- Korea
- Taiwan
- Singapore
- India

Language

- Japanese
- English

For more information

URL : <https://www.contec.com>

Contact: **CONTEC CO., LTD.**

3-9-31 Himesato, Nishiyodogawa-ku, Osaka 555-0025 JAPAN

[E-mail: intsales@jp.contec.com]

TEL: +81-6-6477-5219

URL: <http://www.contec.com>

CNC with EtherCAT Master integrated



CNC 8060/65/70 families

Features

- Easy programming. There is no need to know ISO programming language.
- Algorithm that provides the best performance, speed and accuracy in the machining process.
- Ergonomic and functional design (touch-screen, easy navigation, integrated manuals, sms communication, high-resolution graphics, keyboards and monitors with the highest level of sealing protection, etc.)
- Interface customizing tools.
- Free software download with no time limit to work at any PC.
- Axis position control (position loop) every 250 μ s.
- High Speed Machining and Look-Ahead up to 2400 blocks and block processing time of 0.25 ms.
- EtherCAT master integrated in the CNC, with the following operation modes implemented: interpolated position mode, cyclic sync position mode, cyclic sync velocity mode, cyclic sync torque mode, homing mode.
- "KPA Studio" EtherCAT configurator, from Koenig-pa GmbH, supplied under license.



Specification

	CNC 8060/65/70	
Models	Integrated: 	Modular: 
System	<ul style="list-style-type: none"> • Single or dual core processor, depending on the CNC model. • RAM: 2 GB. • Non-volatile RAM (FRAM). • Storage (SO, CNC and user programs):- Internal 4 GB/8 GB NandFlash. • Storage expansion (optional): CFast 32 GB/128 GB. • SO: Windows 7 (32 bits) / Windows 7A (32 bits multi-touch). 	
Connectivity	<ul style="list-style-type: none"> • 3 USB 2.0 ports, (one accessible at the front, protected by a cover). • 1 USB 3.0 port • 1 Ethernet port for 10/100/1000 BaseT connection. • CAN Bus (CANfagor/CANopen). • Sercos II / Sercos III / EtherCAT regulation buses. • EtherCAT bus for I/Os 	
Inputs/outputs	<ul style="list-style-type: none"> • 16 opto-coupled digital inputs (24 V DC). - IEC61131-2 type 1 and type 3 compliant. • 8 opto-coupled digital outputs (24 V DC, 500 mA). - ON cycle: minimum 75 μs (25 μs, optional in two of them). • 1 analog outputs (\pm10 V, 16-bit resolution). • 1 feedback inputs (5 V, 250 mA). - Incremental TTL signal, differential TTL or 1 Vpp. - SSI or EnDat communication protocols. - Frequency: 100 kHz (TTL), 1000 kHz (TTL differential) / 500 kHz (1 Vpp). • 1 relay with one normally open contact (1 A at 24 V). • 2 probe inputs (5 V or 24 V) • 1 entry for UPS unit control. • 1 input for three handwheels with A and B signals (5 V DC TTL) (only C65-10K). 	

Application Sample

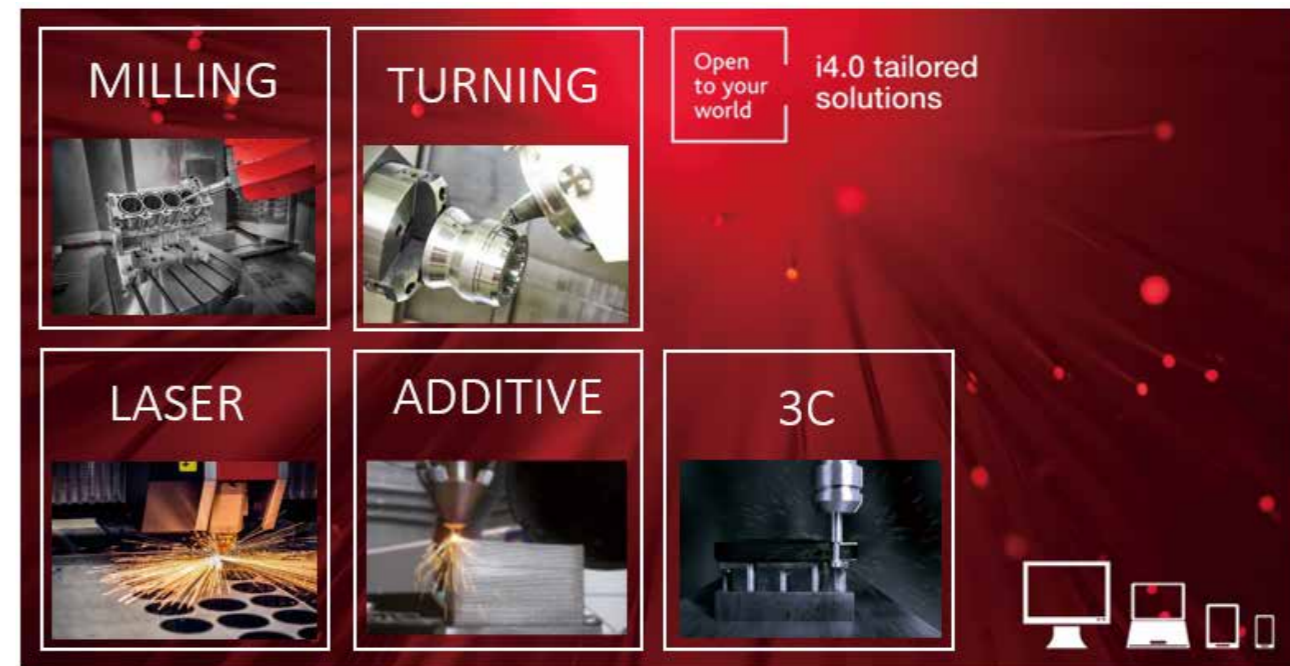

System Configuration

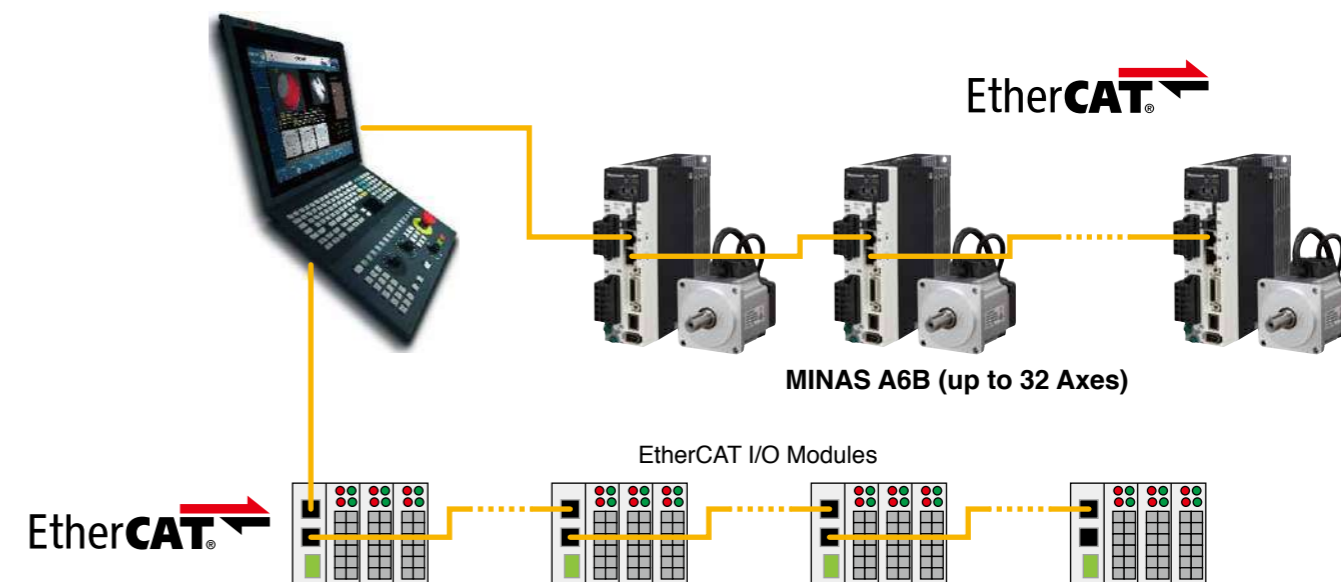

Sales area

- Japan
- Singapore
- EU
- China
- India
- Worldwide response
- Korea
- United States of America
- Taiwan

Language

- English
- French
- Russian
- Spanish
- Basque
- Czech
- Italian
- Portuguese
- Korean
- German
- Chinese
- Dutch

For more information

URL: <https://www.fagorautomation.com/en/>

Contact: **Fagor Automation, S. Coop.**

Bo San Andrés No19 E-20500 – Arrasate/Mondragón, Spain

[E-mail: info@fagorautomation.es]

TEL: +34 943 039 800 FAX: +34 943 791 712

EtherCAT Master Controller

Model DMC-50000

Features

- Configurable controller for up to 8 axes of EtherCAT Master with any of the first 4 axes for local control or EtherCAT Master
- 10/100BASE-T Ethernet port; (1) EtherCAT Port; (2) RS232 ports up to 115 kbaud
- Available with internal, multi-axis servo or stepper drives. Or, connect to conventional external drives (only first four axes)
- For local axes, accepts up to 22 million counts per second of quadrature encoder for servos; Outputs up to 6 MHz for steppers; EtherCAT command speed up to 1 billion counts per second
- Sample times as low as 375 microseconds for 1-4 axes and 750 microseconds for 5-8 axes
- First four axes, advanced PID compensation with velocity and acceleration feedforward, integration limits, notch filter and low-pass filter
- Modes of motion include jogging, point-to-point positioning, position tracking, contouring, linear and circular interpolation, electronic gearing, ECAM and PVT
- Ellipse scaling, slow-down around corners, infinite segment feed and feed rate override
- Multitasking for concurrent execution of up to eight application programs
- Non-volatile memory for application programs (4000 Lines), variables and arrays (2400)
- Dual encoders for every local servo axis
- Optically isolated home input and forward and reverse limits for every local axis; Uses EtherCAT drive for home and limit switches
- Uncommitted, I/O:
 - 8 optically isolated inputs and 8 optically isolated outputs
 - Isolated, high-power outputs for driving brakes or relays (local axis only)
 - 8 uncommitted analog inputs
 - High speed position latch and output compare
 - 32 additional 3.3 V TTL I/O (5 V option)
 - More I/O available with RIO PLC
- 2 line x 8 character LCD
- Accepts single 20 - 80 VDC input
- Communication drivers for Windows and Linux
- Custom hardware and firmware options available

System Configuration

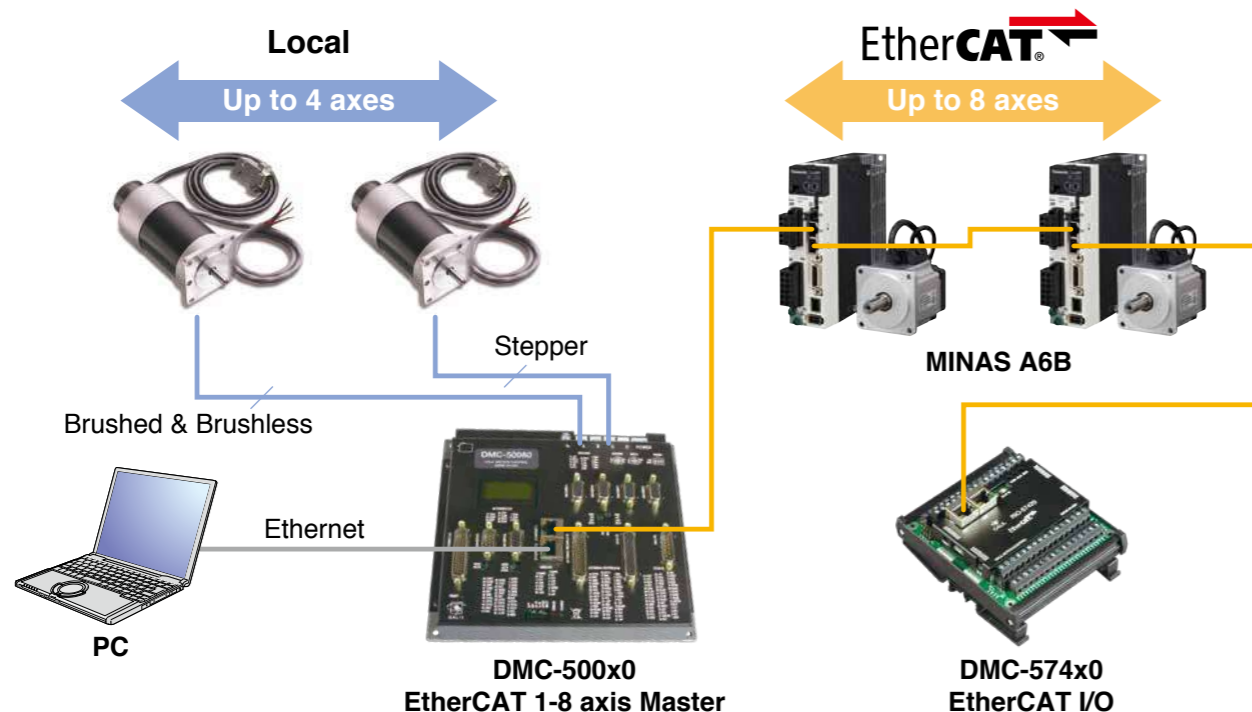

EtherCAT Master Controller

Model DMC-52000

Features

- Available in 2, 4, 8, 16, and 32 axis configurations
- 10/100BASE-T Ethernet port; (1) EtherCAT Port; (1) USB port
- EtherCAT cycle time 1000 microseconds
- Cyclic Synchronous Position mode (CSP)
- Modes of motion include jogging, point-to-point positioning, position tracking, contouring, linear and circular interpolation, electronic gearing, ECAM and PVT
- Ellipse scaling, slow-down around corners, infinite segment feed and feed rate override
- Multitasking for concurrent execution of up to eight application programs
- Non-volatile memory for application programs (4000 Lines), variables and arrays (2400)
- Inputs including forward limits, reverse limits, and homing inputs are located on drives that support these inputs
- Uncommitted, I/O:
 - 8 optically isolated inputs
 - 8 optically isolated high powered outputs
 - 8 uncommitted analog inputs
 - 8 uncommitted analog outputs
 - More I/O available with the RIO-47xxx or RIO-574x0
- Accepts single 120 - 240 VAC input
- Communication drivers for Windows and Linux

Application Sample

Customer Stories URL: <http://www.galil.com/learn/customer-stories>
 Sample DMC Code URL: <http://www.galil.com/learn/sample-dmc-code>

System Configuration

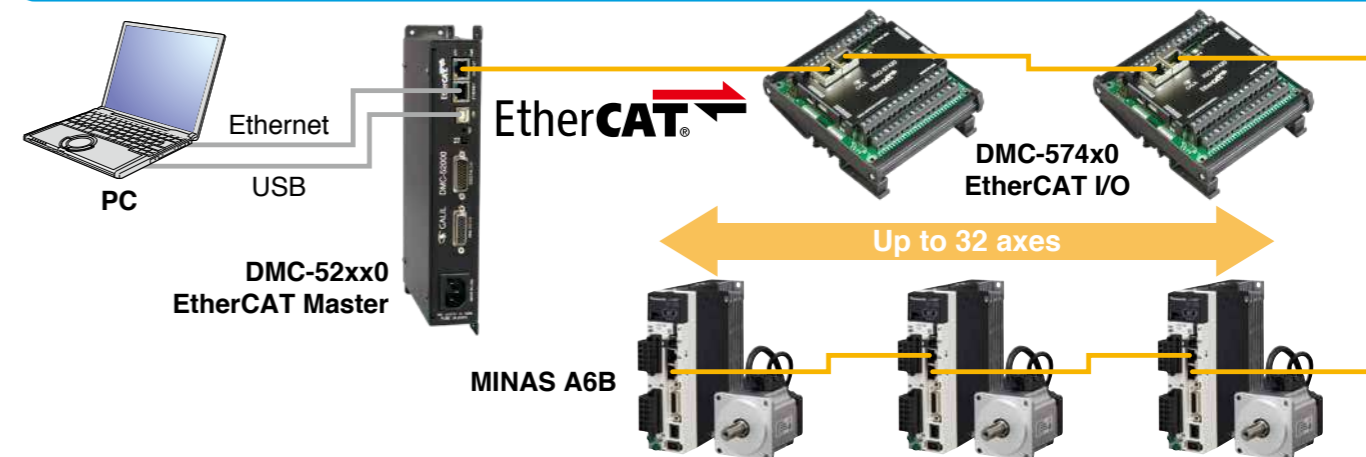

Sales area

• United States of America
 Galil Headquarters in California
 World-wide sales network
 Please see our rep finder tool or contact us for more details.
 URL : <http://www.galil.com/order/find-reps-and-distributors>

Language

• English

For more information

URL : <http://www.galil.com/>

Contact: **Galil Motion Control, Inc.**
 270 Technology Way, Rocklin, CA 95765, United States

[E-mail: support@galil.com]
 TEL: +1-916-626-0101 or 800-377-6329 (US Only)

Motion Control Software · Software Modules

HLS-ECAT02xx/Win, HLS-ECMC02xx/RSI (xx: represents the number of axes)

Features

HLS-ECMC/RSI	HLS-ECAT · Win
EtherCAT multi-axis positioning software module	EtherCAT that can be developed with VC ++, VC #, VB
<ul style="list-style-type: none"> The software module that performs motion control on real time OS Controlling servo driver with EtherCAT communication (CiA 402 drive profile) Control axes will be from 6 up to 64 axes (can be handled in by 1 axis unit) The program is written in C language API functions conforming to international standard specifications Development environment: Visual Studio + INTime SDK <p>* The cycle time will depend on the PC (PDO cycle: 125 μs possible)</p>	<ul style="list-style-type: none"> EtherCAT motion control software by Windows PC Execute real-time processing on the RTOS with Windows as the interface. Easy developing the EtherCAT system Control axes will be 32 axes Motion control can be embedded into Windows application development Development environment: Visual Studio 2008 or later (VC++, VC#, VB) <p>* The cycle time will depend on the PC (PDO cycle: 125 μs possible)</p>

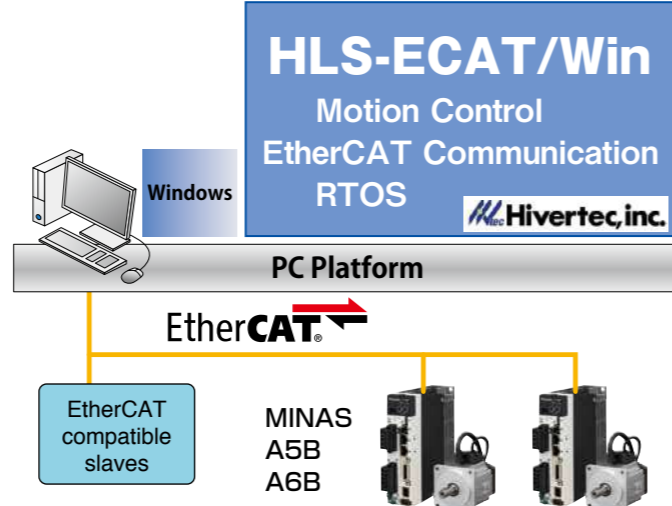
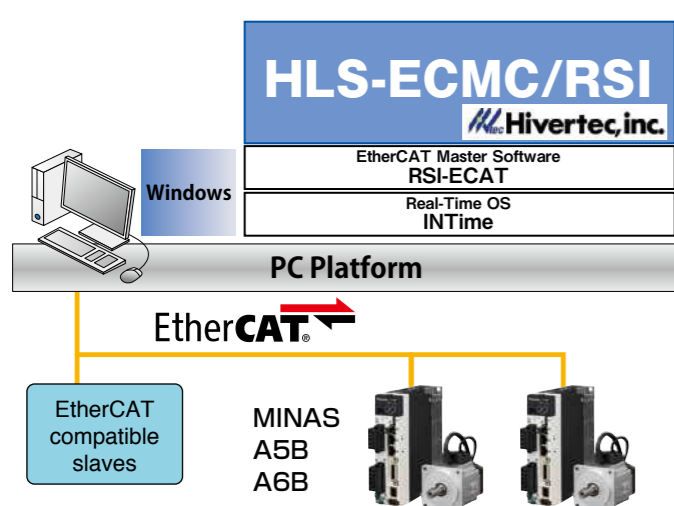

Specification

API Function List (not all)

Administrative	Motion	I/O
MC_InitAxisSetting Initializes axis setting	MC_Home Homing	IO_inp Reads address 1 byte within slave
MC_GetAxisSetting Acquires axis setting	MC_MoveAbsolute Absolute positioning	IO_inpw Writes address 1 byte within slave
MC_SetAxisSetting Configures axis settings	MC_MoveRelative Relative positioning	IO_inpdw Reads address 2 byte within slave
MC_Power Enables / disables operation	MC_MoveVelocity Continuous feed by constant velocity	IO_outp Writes address 2 byte within slave
MC_Reset Resets errors	MC_MoveAdditive Relative position override	IO_outpw Reads address 4 byte within slave
MC_ReadActualPosition Reads current position	MC_Stop Stop	IO_outpdw Writes address 4 byte within slave
MC_ReadActualVelocity Reads current velocity	MC_ReadFunctionResult Acquire execution result	
MC_ReadStatus Reads motion state machine	MC_WaitForNextInterrupt Event waiting	
MC_SetPosition Writes setting position in axis	MC_CancelWaitInterrupt Cancel event waiting	
MC_SetOverride Executes velocity override	MC_MoveLinearAbsolute Absolute linear interpolation	
MC_TouchProve Latches with trigger input	MC_MoveLinearRelative Relative linear interpolation	
	MC_GroupStop Group stop	
	MC_MovePath Curving interpolation	

- Common Spec.**
 - Acquire slave information
 - Homing
 - Continuous feed
 - Relative/absolute Positioning
 - Velocity override etc.
 - Acquire current position, velocity
 - Acquire axis sensor information
- Below is only for "HLS-ECAT/Win"**
 - Relative/absolute Linear Interpolation
 - Interpolation (by specified passing points)
 - Acquire Diagnosis message
 - Various parameter input/output via SDO communication
 - Data input/output to peripheral devices (analog devices, Digital input/output devices, etc.) etc.

IPC base PAC (Programmable Automation Controller)

HCOS series

Features

- Easy to use**
→ The open international standard IEC 61131-3
- Stable supply**
→ Cooperated with IPC manufacturers
- Benefits of using a PC**
→ Huge memory, storage, connectivity with the network, Windows
- Real time**
→ PLC operating on RTOS



Programmable Automation Controller to realize the above

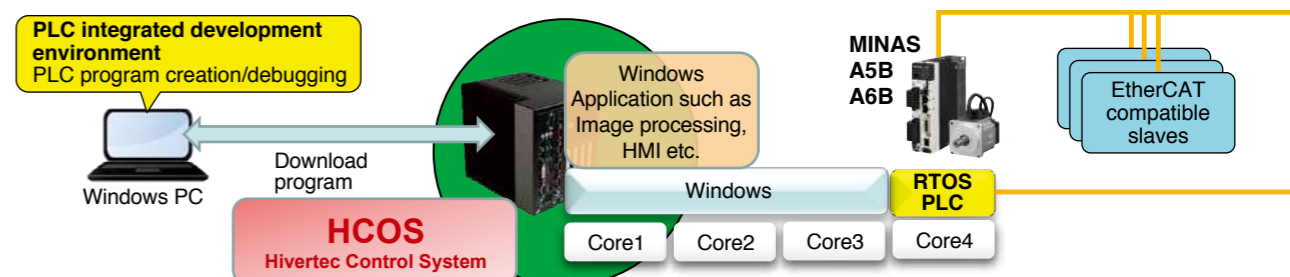

Specification

- IPC**
A variety of platforms that can be chosen, such as BOX PC, 19 inch rack, Wall mount, Panel PCs etc. Customizable for such as CPU, Mmemory, Storage, External interface (Such as RS-232C, USB, Expansion slot etc.), Response to standards etc.
- EtherCAT Specification**
EtherCAT Master Class A + Cable Redundancy + Motion Control
- PLC Specification**
 - Task**
 - Task type** : Cyclic task, Event task, Freewheeling, Status task
 - Number of Task** : up to 100
 - Task Priority** : 32 Levels
 - Period of cyclic task** : Minimum 50 μs
 - Development Language**
Corresponds to 6 development languages, such as IL, LD, FBD, ST, SFC, CFC
 - Debugging**
Capable of Writing during operation, Editing online, Tracing
- Motion Functions**
These functions are possible such as Continuous feed, Relative/Absolute positioning, Velocity override, Acquisition of current position/velocity, Acquisition of axis sensor information and others. Functions such as Interpolation including kinematics are to be added sequentially

Sales area

- Japan
- Korea
- Taiwan

Language

- English
- Japanese

For more information

URL : <http://www.hivertec.co.jp/>

Contact: **Hivertec, Inc.**

Taijuseimei shin-ohashi Bldg., 1-8-11 Shin-ohashi Koto-ku, Tokyo, 135-0007, Japan

[E-mail: sales@hivertec.co.jp]

TEL: +81-3-3846-3801 FAX: +81-3-3846-3773

Industrial plate, sheet, and pipe/tube cutting CNC

EDGE[®] Connect CNC

Features

- Industrial PC-based CNC for X/Y gantry machines.
- Built-in motion control logic for straight “I”, Bevel, & Pipe/Tube cutting.
- Two hardware configurations
 - 495 mm (19.5” in) touchscreen display with integrated hardware operator[®] panel.
 - Compact PC for integration of custom operator[®] panel and display.
- A proprietary graphical User Interface (GUI) for intuitive machine operation.
- Integrated torch height control (positioner) for plasma cutting.
- Real-time operating system for precise motion and process control.
- Embedded process control for oxyfuel, plasma, and waterjet.
- On-screen operator[®] console for station and process control.
- Optional PLC available to add custom functionality (IEC 61131 compliant).
- ProNest[®] CNC nesting software for optimal plate utilization and embedded process control.
- SureCut[™] technologies (True Hole[®], Rapid Part[™] and True Bevel[™]) for improved cut quality, productivity, and operating cost.
- Remote Help[™] for system diagnostics and troubleshooting via the internet.
- Global sales and service.



Companion products available

- ProNest[®] CAD/ CAM Software
- Conventional Plasma Systems
- HyPerformance[®] Plasma Systems
- Plasma Consumables
- Torch Height Controls
- HyPrecision[™] WaterJet Pumps
- Waterjet Consumables

Application Sample

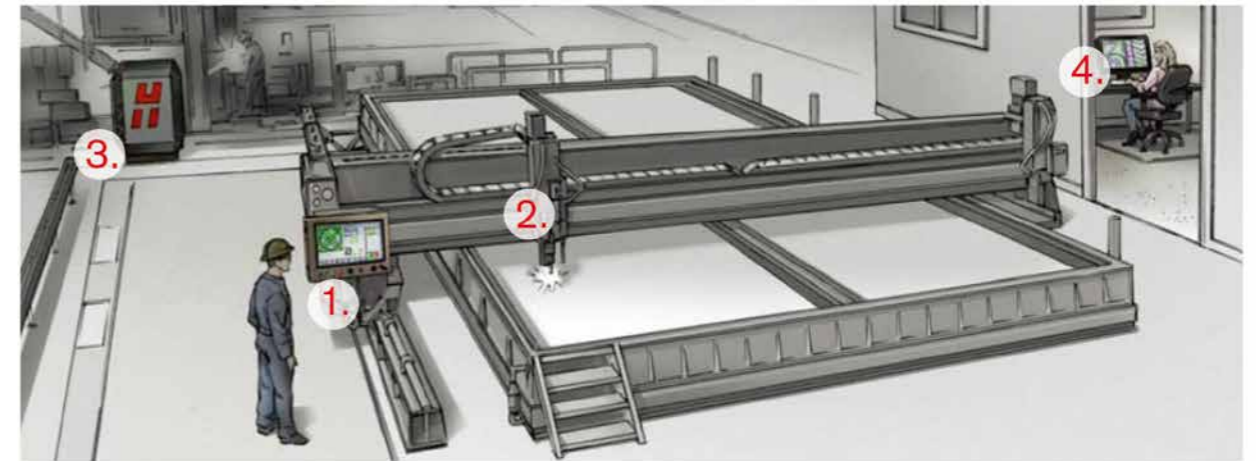

1. CNC control



2. THC lifter



3. Plasma cutting tool



4. Office CAM

System Configuration

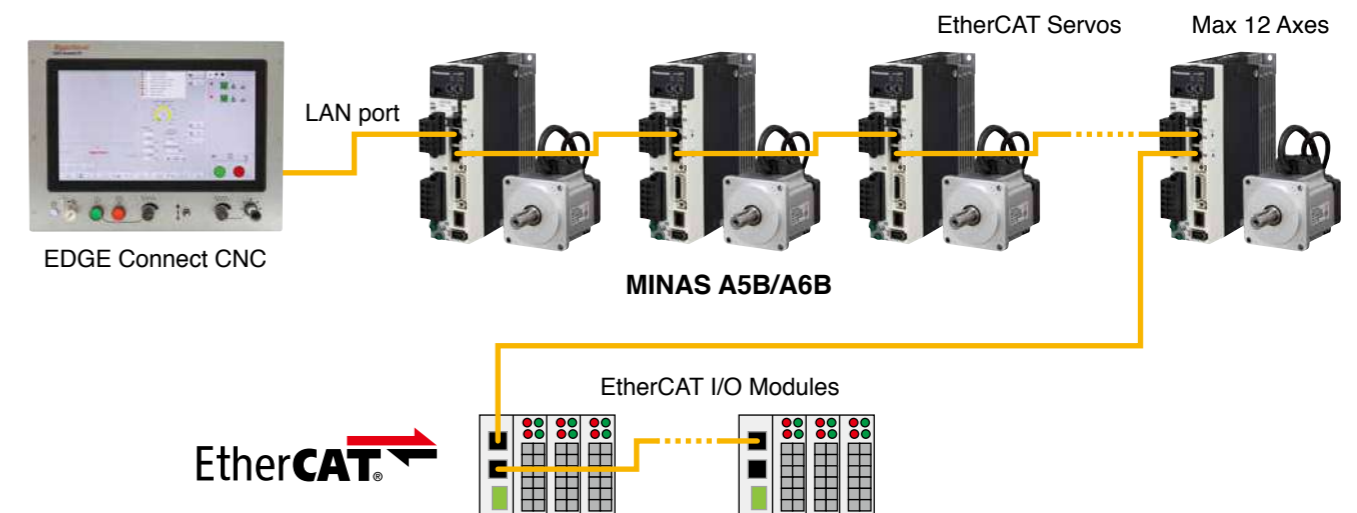

Sales area

- Worldwide response
- Please contact the following address for details.

Language

For more information

URL : www.Hypertherm.com

Contact: **Hypertherm, Inc.**

21 Great Hollow Road Hanover, NH 03755 USA

TEL: +1-603-643-0030

Software CNC COSTANTINO CNC

Features

Costantino is a **SoftCNC** that can be completely customized by OEM customer to create their own CNC solution, using proven and robust components.

Costantino **runs on any** IPC so you can choose your favorite brand that can guarantee international support on hardware components. It runs completely independent on Windows using its dedicated CPU processors in a multicore environment using its dedicated memory amount and its Ethernet controller. Costantino connects with servo and IO devices of any brand using its integrated **EtherCAT master and configurator**. If customer wishes to use different fieldbus such as **Mechatrolink or CANopen**, Costantino can interface an ISAC-provided EtherCAT slave device that provides compatibility with all of these interfaces, and more. In addition to the natively supported fieldbuses, OEM customers can add support to any other fieldbus using an SDK that allow to easily develop by themselves or using ISAC engineering help.

Costantino comes with a PLC environment that is compatible **IEC61131-3**, so you can program it with any of the languages that are part of the standard: ST, IL, LD, FBD, SCD. In addition, you can create FBs in C language and thus reuse components written for different hardware solutions.

Costantino CNC interprets **G-codes** (ISO6983) with some features that are important in many application; with 25000 blocks/sec and more than 250 blocks of look ahead, it is one of the fastest CNC in the market.

- All movements are under **Jerk** control for tooltip and joints, this guarantees the best mechanics lifetime and performance;
- It runs up to 8 different interpolation programs at the same time, and handle auxiliary axes for clams, loaders and unloaders, or tool change, for a total of 128 axes;
- It supports **High Speed Machining**, that keeps cutting feedrate constant, reduces machining timing, and reduces machine vibrations;
- It comes with high accurate vibration suppression algorithms, following error compensation, velocity feed forward and many other tools to achieve the best cutting results;
- It compensates **tool length and radius**;
- It can handle online tool measures, tool wearing and life, and complex tool change procedure;
- It includes **5 axis machining interpolator** to program tool tip in machines equipped with bi-rotative heads, tilting tables, and even robots.
- It comes with a powerful **simulation engine** capable of showing results on the material before machining takes part.

Application Sample

- Stone Cutting
- Metal Milling
- Thermal Cutting (Plasma, Laser, Oxi)
- Waterjet
- Glass Cutting
- Glass Engraving
- Wood Working
- Dental Applications

System Configuration

- Software CNC Costantino
- Panel PC or Industrial PC
- EtherCAT Bridge for connecting servodrivers and I/Os

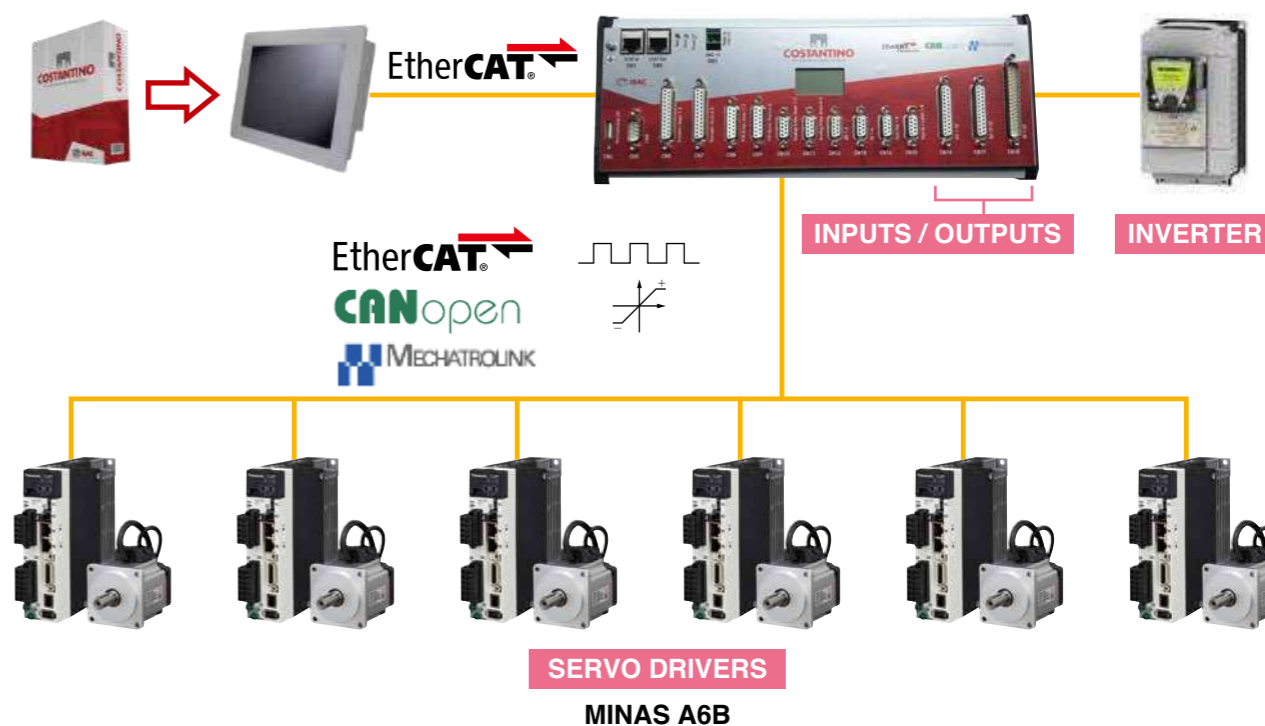

Sales area

- EU
- United States of America
- China
- Korea

Language

- English
- Italian
- Turkish
- Chinese
- Portuguese

Please contact us for details.

For more information

URL : www.costantinocnc.com

Contact: **ISAC s.r.l.**

Via Maestri del Lavoro, 30, 56021 CASCINA (PI) - Italy

GTT co. LTD (Stone Market representative for China)

Mr. Jason Ou

[E-mail: isacsrl@isacsrl.eu] URL: www.isacsrl.eu

TEL: +39 (0)50 711131 FAX: +39 (0)50 711472

[E-mail: 46092672@qq.com]

TEL: +86 139 5951 0697

Programmable Automation Control

PAC ILIUM

Features

Ilium is a newly developed PAC (Programmable Automation Controller) based on more than 10 years of ISAC experience in the field. It includes all main functionalities needed to build an Industrial Automation application, all in one device: **PLC Logic Execution + Motion Control + Communication and integration with other software components + HMI.**

Those functionalities **do not interfere between each other**, as it is possible to use more than one core of the processor; all of the tasks are executed with **high precision** and with **defined execution times**. Ilium interfaces with other devices through an Ethernet port that supports **EtherCAT** or **Powerlink**. Using the ISAC Bridge, Ilium supports many other fieldbuses (**CANopen, Mechatrolink, Analog interface** with position reading through **Encoder, SSI or ENDAT, Pulse/Direction** or **Stepper** interface). Ilium offers complete diagnostic tools for faults and anomalies detected on the I/Os peripherals and on the servo drivers. All of the errors are stored, allowing to analyze them at a later time, even in the case of unattended operation.

Ilium is available in **two formats**: the application is **portable** between different formats, the development tools are the same, as well as the application libraries.

Ilium Embedded is a compact device, powerful enough to drive **up to 11 EtherCAT axes**. It is available with **touch screen**, it supports **USB, COM** ports, external **HDMI** video, one **Ethernet** port for programming and Web interfaces.

It does not contain moving parts, all of the components are non-removable, few Watts are enough to allow it to run.

Ilium soft-Motion is a **real-time software** that runs on an IPC; it uses exclusively **a part of the hardware resources**: one or more cores of the CPU, a portion of RAM, one Ethernet port; communication and HMI is managed by Windows. **You can choose the PC**: choose the ISAC model that suits your needs, or your preferred IPC supplier.

Ilium soft-Motion comes with no performance compromises, and offers the flexibility and the power of the PC to realize a customized user interface, using ISAC tools or alternative ones.

Ilium offers powerful and integrated development tools in order to make easier the PLC logic development and its debug, the start-up of the machine or of the plant, and its maintenance. You can develop the application in the IEC61131 standard languages (ST, IL, LD, FBD, SCD). Program the PLC logic with Multiprog, from Phoenix Contact Software. You can also use ANSI C, and compile in native code, in order to obtain the maximum performance and reliability, to create whole tasks with this language, or to create FBs to be used inside Multiprog. Ilium supports PLCopen MC part 1 and 2, version 2.0. The supplied FBs includes Cams (programmable from PLC logic or to be created from sampling), Gears, Electric Shafts, Phasing, Slave Synchronous Movement (referred on more Masters), all movements based on space or speed control, with speed, acceleration and Jerk control to assure fluid movements and the dampening of the resonances. The servo drivers can be tuned using the integrated diagnostic tools, as the oscilloscope, and all of the parameters will be stored and sent to the servo drivers by Ilium itself, making the replacing of servo drivers very easy.

ISAC ILIUM: TRY TO STOP IT!

Application Sample

- Packaging
- Material Handling
- Printing machines
- Building Automation
- Textile machines
- Paper processing machines

System Configuration

x86 version

- Software PAC ILIUM x86
- Panel PC or Industrial PC
- EtherCAT Bridge for connecting servo drivers and I/Os

EMBEDDED version

- ISAC ILIUM Carrier Board
- Software PAC ILIUM Embedded
- Optional EtherCAT Bridge for connecting servo drivers and I/Os

Sales area

- EU
- United States of America
- China
- Korea

Please contact us for details.

Language

- English
- Italian
- Turkish
- Chinese
- Portuguese

For more information

URL : www.isacsrl.it

Contact: **ISAC s.r.l.**

Via Maestri del Lavoro, 30, 56021 CASCINA (PI) - Italy

GTT co. LTD (Stone Market representative for China)

Mr. Jason Ou

[E-mail: isacsrl@isacsrl.eu] URL: www.isacsrl.eu

TEL: +39 (0)50 711131 FAX: +39 (0)50 711472

[E-mail: 46092672@qq.com]

TEL: +86 139 5951 0697

EtherCAT Closed Loop Stepper Drives

CS3E Series

Features

- No loss of step, Smooth, Quick, Accurate, Low heating
- Support CANopen over EtherCAT (CoE) control and CiA 402
- Operation modes: Cyclic Synchronous Position (CSP), Profile Position (PP), Profile Velocity (PV) and Homing (HM)
- Compatible with major EtherCAT masters and slaves
- Stepper motors with 1000, 2500, 5000, and 10000 PPR encoders



Specification

Drive Specifications

Models				
	CS3E-D503	CS3E-D507	CS3E-D728	CS3E-D1008
Operating Voltage	20 VDC - 50 VDC	20 VDC - 50 VDC	20 VDC - 72 VDC	20 VDC - 80 VAC or 30 VDC - 110 VDC
Output Current	0.3 A - 2.5 A (RMS 1.8 A)	1.0 A - 7.0 A (RMS 5 A)	2.1 A - 8.0A (RMS 6 A)	3.2 A - 8.2 A (RMS 6 A)
Matched Motor	NEMA 11, 14, 17	NEMA 23, 24	NEMA 23, 24, 34	NEMA 34

EtherCAT Specifications

Item	Description
Physical Layer	100 BASE-TX full duplex
Communication Connector	RJ45 × 2 (ECATIN, ECATOUT)
Topology	Line, tree or star
Baud Rate	2 × 100 Mbps (full-duplex channel)
Frame Data Length	1484 bytes (Max)
Number of Axes	64
Number of Nodes	128 slave nodes max
Cable	Shielded twisted pair, 100 m max between nodes
Synchronization Mode	DC Synchronization (SYNC0) Free Run
Communication Event	SDO, PDO, EMCY
Application Layer	IEC61800-7 CiA402 Drive Profile
Operation Modes	CSP, PV, PP, HM
Cycle Period	500 μs, 750 μs, 1 ms, 2 ms, 3 ms, 4 ms, 5 ms

Matching Closed-loop Stepper Motor

Motor Size	Motor Model	Holding Torque (N·m)	Length (mm)		
			Standard	Brake	Waterproof
NEMA17	CS-M21702	0.2	56		
	CS-M21704	0.4	63		
	CS-M21706	0.6	70		
	CS-M21708	0.8	83		
NEMA23	CS-M22306	0.6	60		
	CS-M22313	1.3	75	109	94
	CS-M22323	2.3	95	131	115
	CS-M22326	2.6	103		
	CS-M22321-L	2.1	86		
NEMA24	CS-M22422	2.2	89	129	113
	CS-M22430	3.0	107	143	130
	CS-M22422B	2.2	89	129	113
NEMA34	CS-M23435	3.5	95		
	CS-M23445	4.5	109	134	115
	CS-M23480	8.0	127		133
	CS-M23485	8.5	147	172	153
	CS-M234120	12	158	183	164

Application Sample

- Packing machines
- Electronic equipment
- Stage entertainment equipment
- CNC Machines

System Configuration

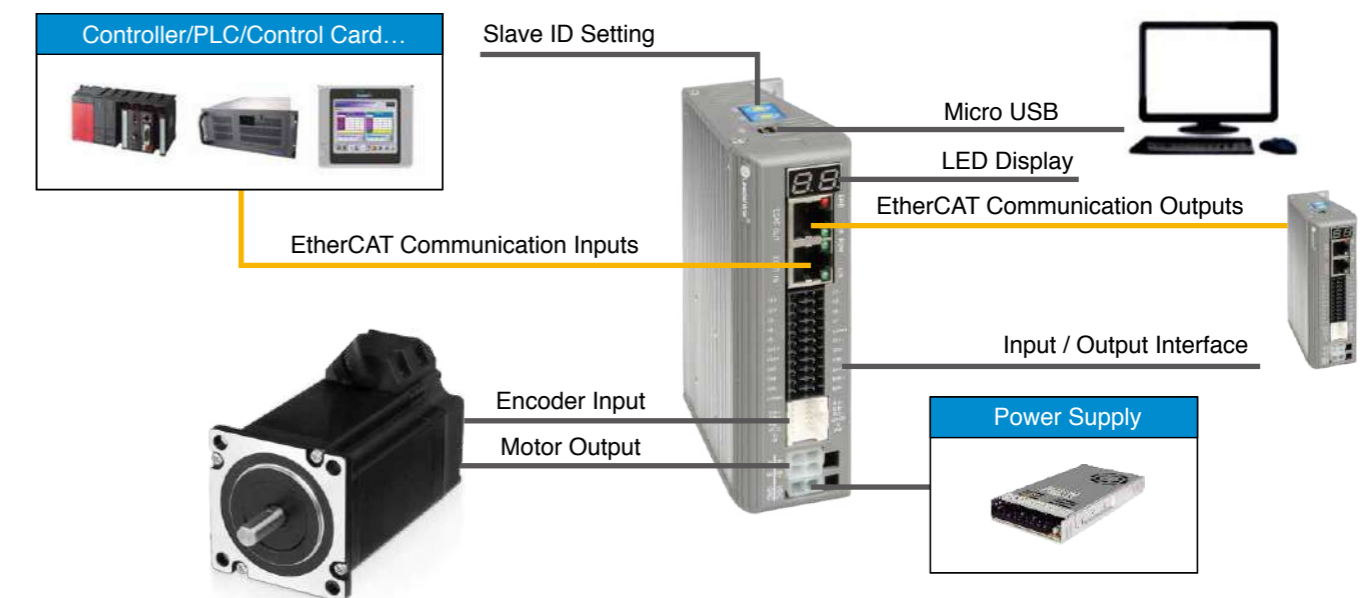

Sales area

- China
- Worldwide response

Language

- English
- Chinese

For more information

URL: <http://www.leadshine.com>

Contact: **Leadshine Technology Co., Ltd.**

11/F, Block A3, iPark, 1001 Xueyuan Blvd, Nanshan District, Shenzhen, China

[E-mail: sales@leadshine.com]

TEL: +86-755-26417674



EtherCAT Stepper Drives

EM3E Series

Features

- Low noise and vibration, smooth motion
- CANopen over EtherCAT (CoE) with full support of CiA402, 100 Mbps full-duplex
- Support operation modes: Profile Position, Profile Velocity, Cyclic Synchronous Position, Homing
- 5 digital inputs, 2 optically isolated digital outputs for EM3E-522 / 556 / 870
7 digital inputs, 7 optically isolated digital outputs for EM3E-A882
- Operation modes: Cyclic Synchronous Position (CSP), Profile Position (PP), Profile Velocity (PV) and Homing (HM)
- Compatible with major EtherCAT masters and slaves



Specification

Drive Specifications

Models				
	EM3E-522	EM3E-556	EM3E-870	EM3E-A882
Operating Voltage	20 VDC - 50 VDC	20 VDC - 50VDC	20 VDC - 80 VDC	20 VDC - 80 VAC or 30 VDC - 110 VDC
Output Current	0.3 A - 2.2 A (RMS 1.6 A)	1.0 A - 5.6 A (RMS 4 A)	2.1 A - 7.0 A (RMS 5 A)	3.2 A - 8.2 A (RMS 6 A)
Matched Motor	NEMA 8, 11, 14, 17	NEMA 23, 24	NEMA 23, 24, 34	NEMA 34

EtherCAT Specifications

Item	Description
Communication protocol standard	CoE (CANopen over EtherCAT)
Equipment protocol standard	IEC61800-7 CiA 402 Drive Profile
Control Modes	CSP (Cyclic Synchronous Position) pp (Profile Position) PV (Profile Velocity) HM (Homing)
Synchronization Modes	DC Synchronization and Free-run mode
Synchronization cycle	250 μs, 500 μs, 750 μs, 1 ms, 2 ms, 4 ms

Matching Stepper Motor

Motor Size	Motor Model	Holding Torque (N·m)	Length (mm)		
			Standard	Brake	Waterproof
NEMA17	42CM02	0.2	33		
	42CM04	0.4	40		
	42CM06	0.6	47	79	
	42CM08	0.8	60	92	
NEMA23	57CM06	0.6	41		
	57CM13	1.3	55	96	65
	57CM23	2.3	76	116	90
	57CM26	2.6	84		
	D57CM21	2.1	67		
NEMA24	D57CM31	3.1	88		
	60CM22X	2.2	67		
NEMA34	60CM30X	3.0	85	124	
	86CM35	3.5	65		
	86CM45	4.5	80	114	90
	86CM80	8.0	98		
	86CM85	8.5	118	152	130
	86CM120	12	129		

Application Sample

- Packing machines
- Electronic equipment
- Stage entertainment equipment
- CNC Machines

System Configuration

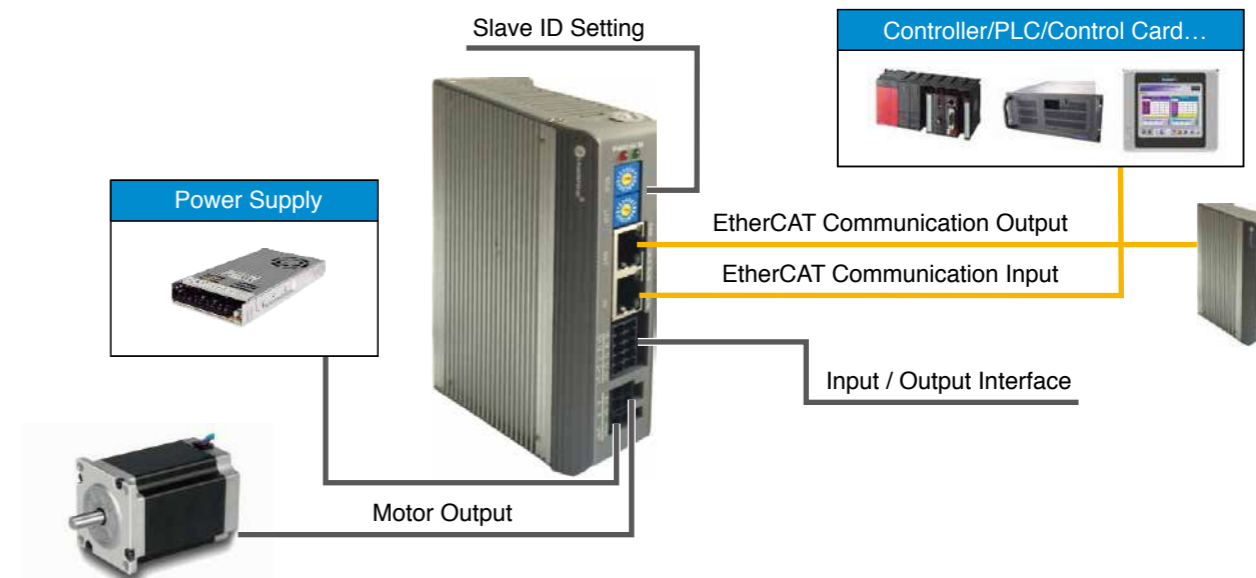

Sales area

- China
- Worldwide response

Language

- English
- Chinese

For more information

URL: <http://www.leadshine.com>

Contact: **Leadshine Technology Co., Ltd.**

11/F, Block A3, iPark, 1001 Xueyuan Blvd, Nanshan District, Shenzhen, China

[E-mail: sales@leadshine.com]

TEL: +86-755-26417674

PC Based Controller RT-C Language Controller

Features

RT-C Language Controller for Windows can give determinism to ensure predictable behaviors and can support real-time tasks to standard Windows platforms.

Though Windows is a global standard on human machine interfaces (HMI) and on other general purpose operating system (GPOS) functions, but only Windows cannot provide deterministic supports for real-time application needs.

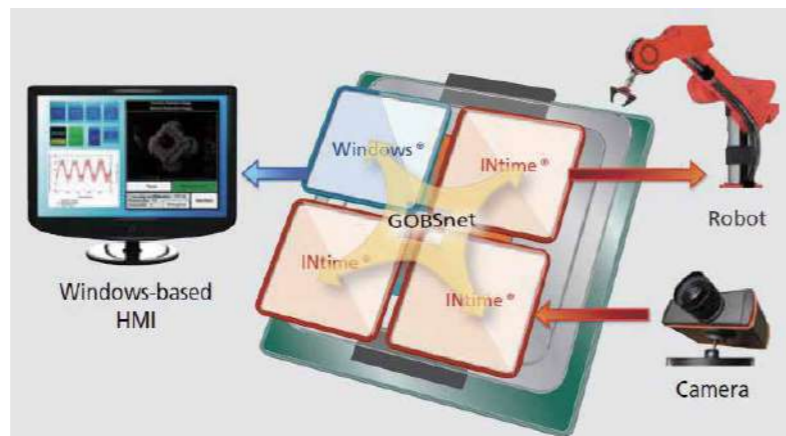

● Complete RTOS for Windows platforms

RT-C Language Controller is a controller which can achieve 100 μs period high-speed real time control.

You can realize both real time instrument control function and multi-purpose Windows function on 1 PC platform.

since it can also run on Windows.

● Machine control by RT-C Language Controller

RT-C Language Controller which makes use of PC platform can offer unmatched performance since it uses latest Intel CPU.

In developing control program, since it adopts the integrated development environment "Visual Studio" which is the most popular all over the world, if you have experienced Windows programs with C# language, you can smoothly introduce it to your systems.

System Configuration

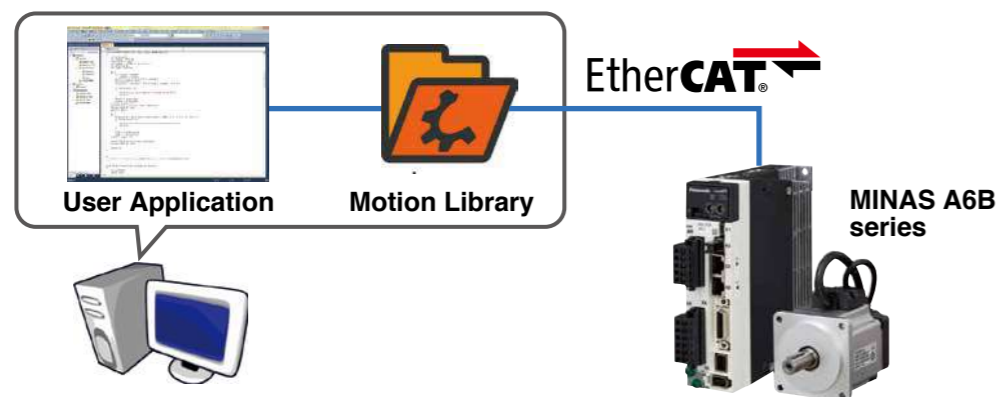

Specification

Priority Scheduling	0 (highest) - 16 (lowest) 16 levels
Constant Scan Time	More than 0.1 ms
Number of Maximum Tasks	16
Data Area Size	64 MB
Supported OS	Windows10, Windows8.1, Windows8, Windows7 [32 bit/64 bit]
Development languages and Environments	Visual Studio 2008/2010/2013/2015 * More than Professional Edition

PC Based Controller INplc PLC based on IEC61131-3

Features

● INplc-Controller with "INplc Runtime License"

The most advantageous point of INplc is that it can be used with Windows together.

It is a multifunctional controller equipped with not only PLC applications but also C language applications / HMI applications.

You can use add-in boards or field buses as I/O interfaces of INplc.

EtherCAT is also contained in the field bus category which INplc supports.

INplc-Controller

- Real-time sequence control
- Network communication function
- High functionality human interface
- Motion Control function



Development Tool INplc-SDK

- IEC 61131-3 Conforming
- Motion Function Block
- Supports language mix



EtherCAT



You can develop and maintain PLC programs on standard Windows PC platforms using it. The created PLC programs can be downloaded to PLC controllers via network.

- INplc has corresponded to 5 languages in accordance with IEC61131-3 that IEC (International-Electrotechnical Commission) provides.
- You can code different languages together in INplc-SDK environment.
- INplc-SDK also allows you to convert across languages.

INplc is a real software-PLC in accordance with IEC61131-3.

INplc adopts MULTIPROG & ProConOS (by PHOENIX CONTACT Software, Germany) which have achieved a lot of satisfactory results in the world. And INplc-Controller adopts INtime and a standard Windows computer as its basic structure.

Therefore,

- No specialized hardware is needed.
- Efficient hardware can be selected from among marketed commodities. From high-end systems to embedded-systems, you can construct various systems with a high-flexibility.

Specification

Priority Scheduling	0 (highest) - 16 (lowest) 16 levels
Constant Scan Time	More than 0.1 ms
Number of Maximum Tasks	16
Data Area Size	64 MB
Supported OS	Windows10, Windows8.1, Windows8, Windows7 [32 bit/64 bit]
Development languages and Environments	IEC61131-3 Language (IL, ST, LD, FBD, SFC), C#

Sales area

- Japan
- Korea
- China
- Taiwan

Language

- English
- Japanese

For more information

URL : http://www.mnc.co.jp/index_E.htm

Contact: Micronet Company

TMY Building 9F,17-13, Hacchobori 3-chome,
Cyuuuou-ku, Tokyo, Japan (Zip 104-0032)

[E-mail: cde@mnc.co.jp]

TEL: +81-3-6909-3371 FAX: +81-3-6909-3373

Teach Worker Intelligent Robot Controller for Any Robot

The World's First Robot Controller with Motion Planning

Features

Industrial Robots for Everyone

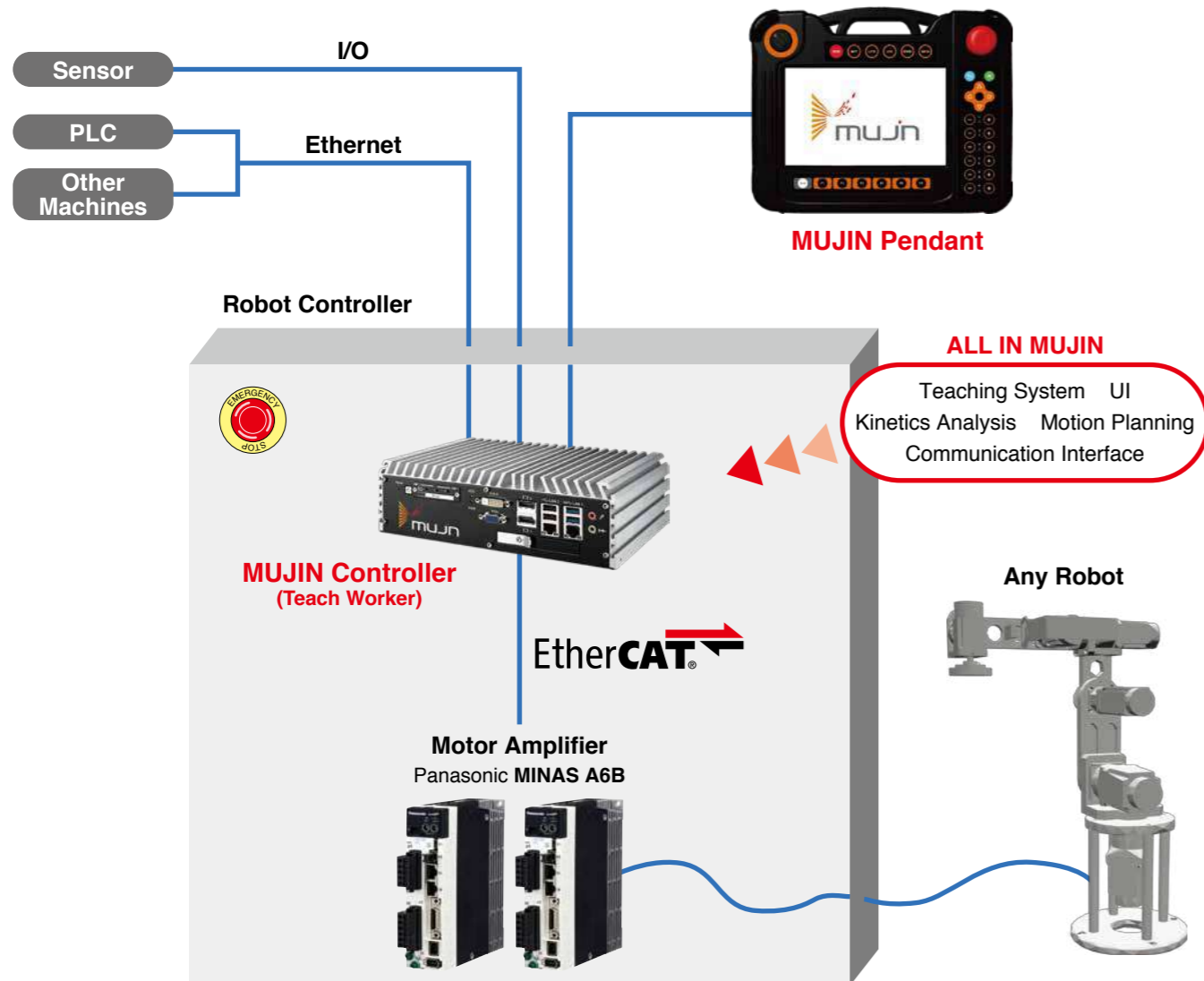

Panasonic "AC Servo Motor"



Integration of Mujin's Teach Worker with "AF Series" or "SHA-P Series" gearbox equipped Panasonic servo motors can be completed within 1 month.

Custom robots only require 1 month or less to integrate

Specification

Innovative User Interface(UI)



"Teach Worker" removes the burden of traditional complex task programming by presenting an interactive user interface with 3D graphics and support for Mujin's optimized programming language ITL.

Less Teaching (Autonomous Collision Avoidance)

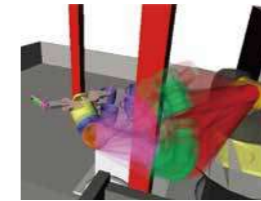

Mujin's motion planning technology with advanced collision avoidance logic can be configured easily, enabling robotics systems to operate in small footprint and complex environments without risk of collision.

CAD/CAM



Welding, laser cutting, and deburring related data can be imported using standard CAD formats to easily produce production-ready tasks.

3D Simulator



A simulator is included that can be used to validate tasks before deployment in real-world environments, reducing overall time to deployment and manual tuning on-site.

Remote Maintenance



You can support robots within your facility remotely regardless of robots location via Mujin's Teach Worker.

Sales area

- Japan
- Worldwide response

Language

- English
- Chinese
- Japanese

For more information

URL : <http://www.mujin.co.jp>

Contact: **Mujin, Inc.**
1-1-9 Narihira, Sumida, Tokyo, 130-0002, JAPAN

[E-mail: info@mujin.co.jp]
TEL: +81-3-4577-7638

Rugged, Reconfigurable Smart Machine Controller

CompactRIO Performance Controller (cRIO-9034, cRIO-9039)

Features

- Motion, Vision, signal-conditioned I/O, and HMI integration on one platform
- High Performance Real-Time processor
- User-Programmable FPGA
- Over 100 signal-conditioned I/O modules to customize your application
- EtherCAT, Ethernet/IP, ProfiBus, ProfiNet, Modbus, OPC UA, and other common buses supported
- Pre-written motion control and vision analysis libraries for real-time and FPGA



Specification

	4-slot Performance	8-slot Performance
Processor	Up to Quad-Core Intel Atom E3845, 1.91 GHz	
Modular C Series I/O Slots	4	8
Control Cycle Time	250 μ s (min.) over EtherCAT	
RAM	Up to 2 GB DDR3 + 128 MB DDR3 for FPGA	
Storage	Up to 16 GB + SDHC Card Slot	
Programming Environments	LabVIEW, C/C++, IEC 61131-3	
Shock/Vibration Ratings	50 G Operational shock; 10 Hz – 500 Hz Random Vibration	
Operating Temperature	-20 °C to 55 °C (-40 °C to 70 °C extended temp models available)	
Operating System	NI Linux Real-Time, 64-bit	
FPGA Type	Up to Kintex-7 325T	
Certifications		

Application Sample

- Machine control systems
- Manufacturing machines
- Pick-and-place machines
- Industrial robotics and automation
- CNC machines
- Vision-guided motion
- Material handling machines
- Hydraulic control
- Power conversion equipment
- Mining and drilling equipment
- Multi-axis motion control
- Machine tools
- Condition Monitoring

System Configuration

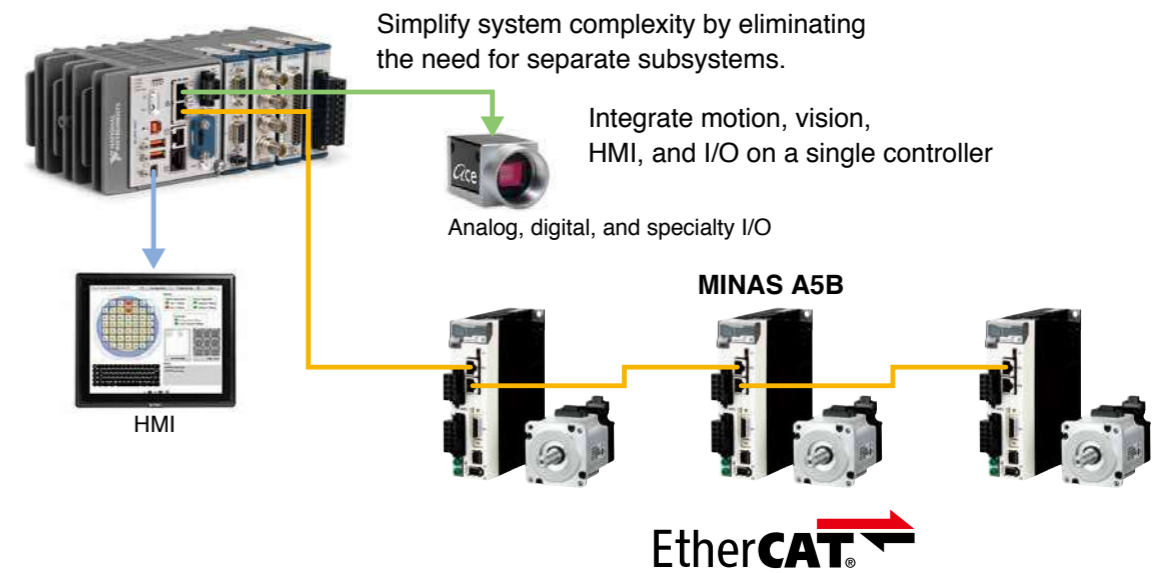

Sales area

- Worldwide response
- Please contact us for details.

Language

- Operations in over 50 countries
- Support for dozens of languages
- Global training and support

For more information

URL : <http://www.ni.com/motion>

Contact: **National Instruments Corporation**
11500 N. Mopac Expy. Austin, TX 78759

[E-mail: support@ni.com]
TEL: +1-866-275-6964

EtherCAT General Motion Controller

NET200-GMC

Features

- Standardized EtherCAT master
- Built-in integrated development environment:
NexMotion Studio
- Master control cycle: 1ms



Specification

Item	Description
NexGMC Runtime	
Axis No.	8 Axes
Cycle Time	1 ms
Single Axis Control Functions	PTP/ Jog/ Halt/ Stop
Single Axis Blending Motion	Aborting/ Buffered/ Blending
Single Axis Command Override	Position/ Velocity/ Acceleration/ Deceleration
Axes Group Types	Cartesian Coordinated
Axes Group Control Functions	PTP/ Linear/ 2D Arc/3D Arc
Axes Group Blending Motion	Aborting/ Buffered/ Blending
Platform Specifications	
CPU	Intel® Celeron® processor J1900 Quad Core 2.0 GHz
Memory	4 GB RAM (2 x DDR3L)
Display	Dual independent display: DVI-I and DP
I/O Interface-Front	<ul style="list-style-type: none"> ● ATX power on/off switch LEDs for HDD LED, Batty LEDs, Power LED, COM port Tx/Rx, 5x programmable GPO LEDs ● 1 x External SD Card ● 1 x SIM card holder ● 2 x Intel® I210AT GbE LAN ports, support WoL, Teaming and PXE ● 1 x DP display output ● 1 x DVI-I display output ● 1 x USB 3.0 (900 mA per each) ● 3 x USB 2.0 (500 mA per each) ● 2 x RS232/422/485 support auto flow control <ul style="list-style-type: none"> - Jumper-free setting on RS232/422/485 - Support 2.5 KV isolation protection on COM1 ● 1 x 3-pin DC input, Typical 24 V DC input with +/-20 % range
Dimensions	85 mm (W) x 157 mm (D) x 214 mm (H)
Certifications	CE/FCC Class A
Operation Environment	Operating system: Windows Embedded Standard 7 Real-time extension: RTX

NexMotion Studio

- EtherCAT devices online scan and offline edit
- EtherCAT master configuration
- PDO mapping edit, online SDO edit
- Import ESI and export ENI
- CiA 402 device operation: CSP
- Single axis operation
- Group axes operation
- I/O mapping edit and operation
- Support simulation mode

System Configuration

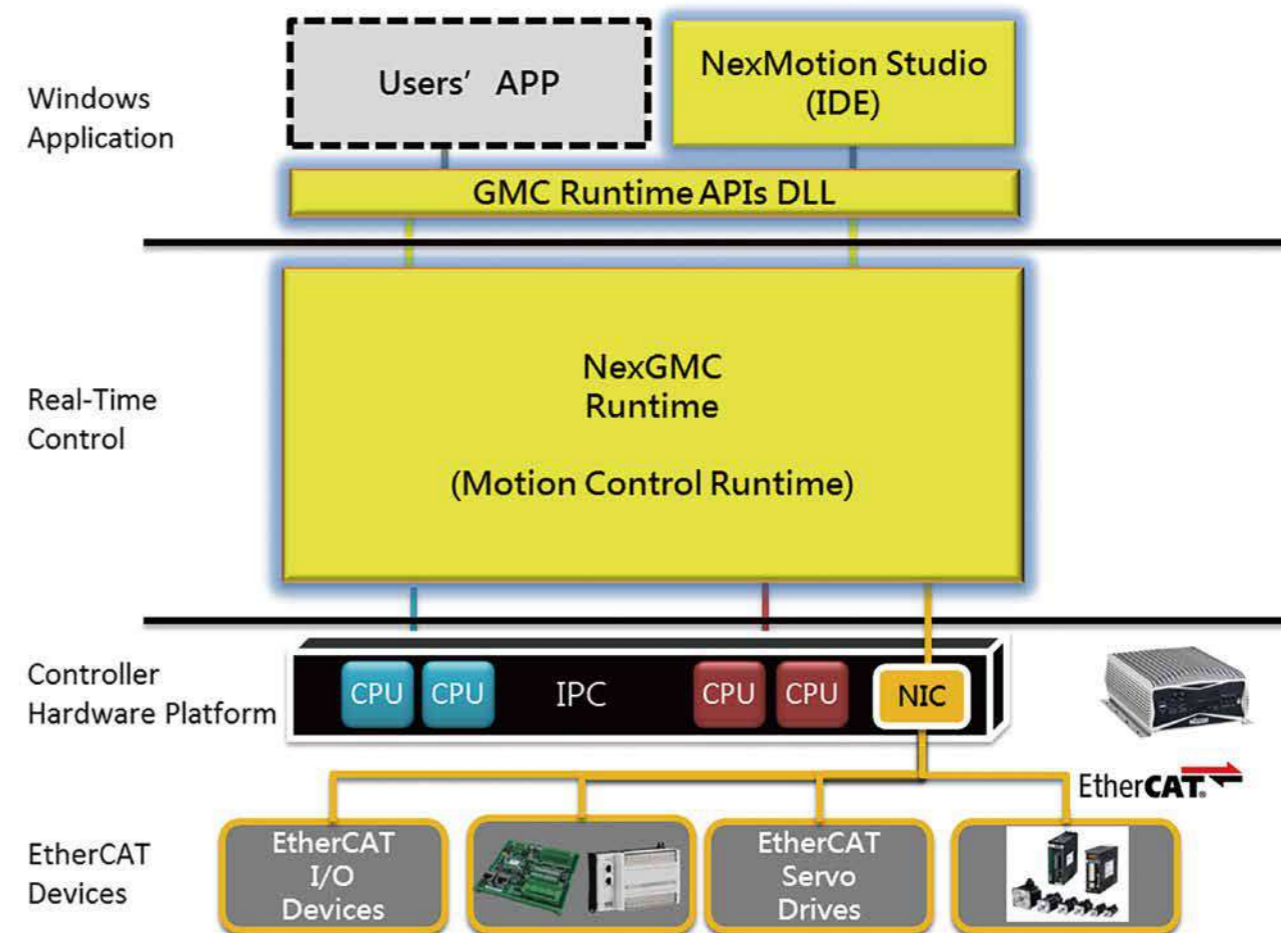

For more information

URL : <http://www.nexcom.com.tw/Products/industrial-computing-solutions/machine-automation/ethercat-motion-controller/ethercat-rx-net-200-ecm>

Contact: NEXCOM International Co., Ltd. / Headquarters

9F, No.920, Chung-Cheng Road, Zhonghe Dist., New Taipei City, Taiwan 23586, R.O.C.
TEL: +886-2-8226-7786 FAX: +886-2-8226-7782 www.nexcom.com

NEXCOM Intelligent Systems / Taipei Office

13F, No.920, Chung-Cheng Road, Zhonghe Dist., New Taipei City, Taiwan 23586, R.O.C.
TEL: +886-2-8226-7796 FAX: +886-2-8226-7792 www.nexcom.com.tw

PC-Based, Advanced Soft Motion Controller

WMX3 for EtherCAT

Features

- Soft Motion Controller WMX3 is a patented software which turns any Windows PC with multi-core CPU a high-speed real time controller for intricate industrial machines. No additional proprietary hardware interface modules or components are necessary.
- WMX3 streamlines its operation systems; it integrates operation screens, image processing and device control applications up to 128-axis.
- Wiring can be reduced by networking. Furthermore, wiring man-hours and material reduction can be realized. Contributes to noise immunity.
- Small cost effective Windows PC enables real time logging simultaneously with controlling various industrial devices. Allows the accumulation of data in the edge PC and instantly retrieves it whenever necessary for its host systems.
- Over 500 API functions for C/C++ and .NET functions for EtherCAT communications, motion control, and I/O control are available to develop original user motion applications.
- Exclusively developed EtherCAT SoftMaster is highly compatible with other slave machines on the market. Allows 32-axis high-speed synchronous communication at 250 μs. Full customer support for transmission and connection problems.
- SDK installed with WMX3 allows for customized motion control systems for various operation needs.

All in One package

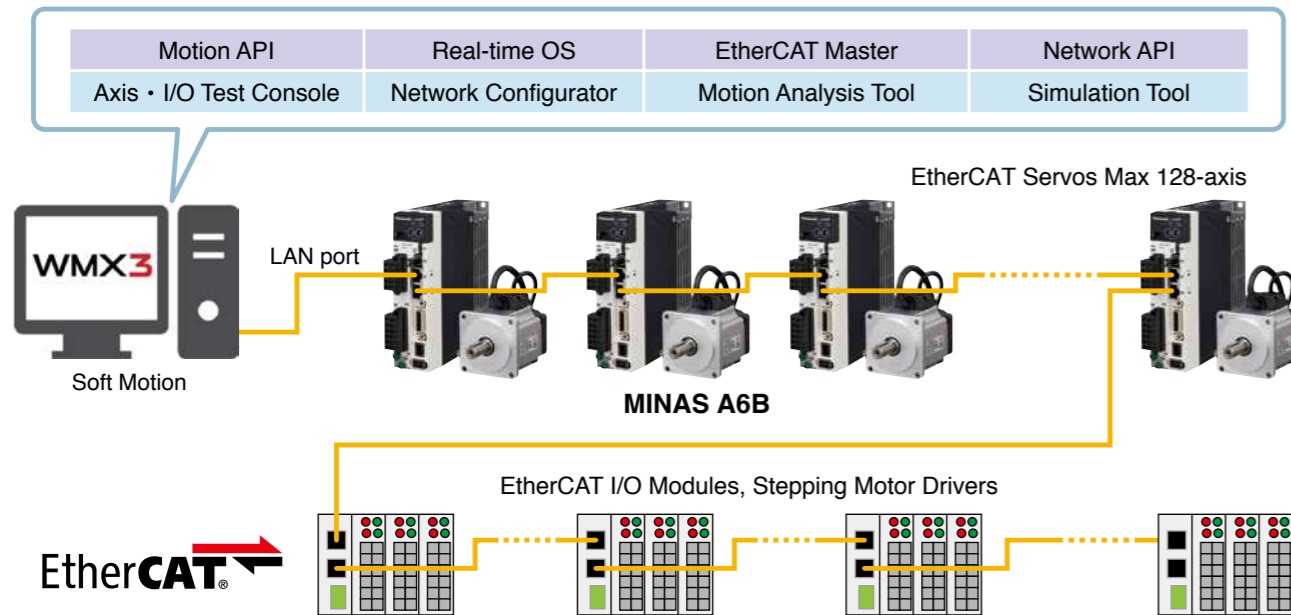

Real Time SDK Package

- Integration with various user algorithms and control functions on real time kernel RTX provides high-end application development environment.
- Integrates user real time motion library as RTDLL with existing functions on WMX3.
- Open platform formation allows high performance motion control customized for user needs.

RTX Subsystem

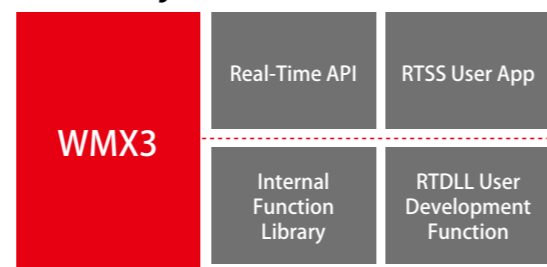

Specification

Number of Axes	Max 128-axis
Interpolation Types	Linear, Arc, 3D Arc, Helical, PVT
Communication / Command cycle	Standard: 1 ms, Shortest: 0.125 ms (Depends on PC performance, axis count)
Command Modes	Position (Standard), Velocity, Torque, Dynamic command mode can be changed. *Depends on servo specifications
Positioning	128-axis * Simultaneous override (Dynamic destination can be changed)
Acceleration / Deceleration Profiles	Speed curve: Trapezoid, S-Curve, Jerk, Two-Step Speed, Acceleration time specification trapezoid, Acceleration curve: S-Curve, Quadratic Curve, Sine Curve
Interpolation Types	Linear, Arc, 3D Arc, Helical, PVT
Continuous Trajectory	Combination of straight line and Arc, Spline interpolation, Automatic prefetch speed control, Linear / Circular continuous trajectory with rotating stage
Gantry Control	Complete synchronous gantry control
Event	Register triggers (reach axis target value, I / O input, etc.) and actions (start axis movement, I / O output, etc.) and execute real-time operations
API Buffer	Register the motion API in the buffer and perform real-time operation. Execution waits and branches can be made depending on conditions.
Position synchronization output (PSO)	Real-time output of I / O at the specified position (position comparison performance depends on the communication cycle). When more precise operation is required, position comparison at 1 pulse level is possible with a dedicated hardware option.
Synchronization Control	Simple synchronization, synchronous gear ratio / offset specification, synchronization deviation correction, dynamic synchronization axis setting / change / cancel. Multiple axes (up to 64 sets for EtherCAT and up to 32 sets for RTEXT) can be defined for single-axis to multi-axis synchronization.
Electronic Cam	8 cam curves can be defined. Cam curve for each communication cycle. Phase manipulation. clutch.
Return to Origin	Index pulse, origin sensor, limit sensor, limit proximity sensor, external input signal, mechanical end, etc. It is possible to return to the origin of the gantry axis.
I/O	11600 inputs / 11600 outputs, Supports most commercial EtherCAT I/O modules
Compensation Function	Pitch error, Backlash, Straightness correction
API Supported Language	C Language (C/C++), .NET Languages (C#, VB), .NET Framework: 4.0 or later
Development Environment	Microsoft Visual Studio 2012, 2013, 2015, 2017, LabVIEW, Python 3.6
Recommended Operating Environment	OS: Windows 7 (32-bit/64-bit), Windows 10 (64-bit), IoT Enterprise LTSC CPU: Min. ATOM 2 GHz (E3845, etc.) 2 cores or more, Memory: 4 GB or more

Utility Tools

EcConfigurator

- Communication setting, status monitoring tool
- Parameter upload / download via network
- Network topology display function
- Network diagnosis function



Profile Analyzer

- Tool for displaying multi-axis motion in real time or from log data graphically
- Timing control by trigger setting is possible
- Trajectory analysis for multi-axis interpolation

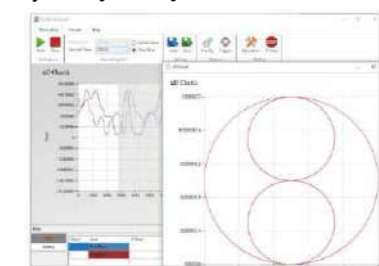

Sales area

- Japan
- United States of America
- China
- Korea
- Taiwan

Language

- English
- Japanese
- Korean
- Chinese

For more information

URL WMX3 for EtherCAT : <https://softservo.co.jp/products/wmx3/>

Contact: **Soft Servo Systems, Inc.**

[E-mail: sales@softservo.com]

3-1-13 AS Building 2F, Nishiki-cho, Tachikawa, Tokyo 190-0022, Japan

TEL: +81-42-512-5377 FAX: +81-42-512-5388

PC Based Fine Motion

RTMC64-EC

Features

● **PC Based Fine Motion is a controller software for EtherCAT.**

Your PC becomes a high performance motion controller. PC Based Fine Motion whose ability is several hold higher than that of a general NC or a robot controller controls at most eight precise machines by one PC.

The reliability of your controller can be improved by "INtime" and FAPC(Factory Automation PC).



Specification

High-speed

0.25 msec / 32-Axis
0.5 msec / 64-Axis

Reliability

Not depend on Windows

Multi Axis Control

64-Axis / 8 task

8 task controlled simultaneously

One PC controls 8 machines

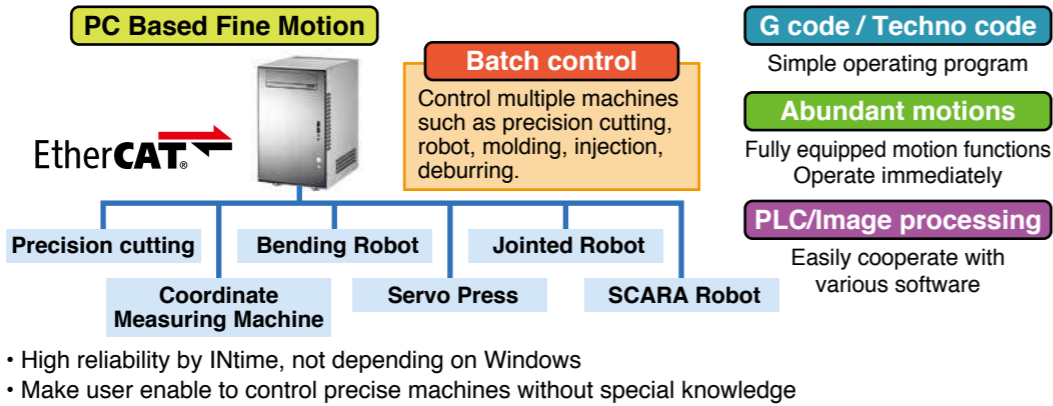

- High reliability by INtime, not depending on Windows
- Make user enable to control precise machines without special knowledge

Application Sample

- Precision cutting
- Robot
- Laser cutting

● Injection Molding

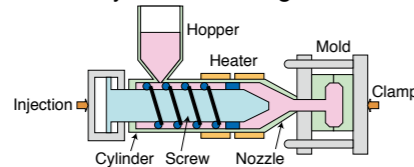

● Winding machine

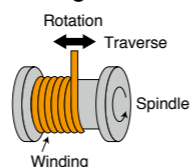

System Configuration

FAPC (Factory Automation PC)

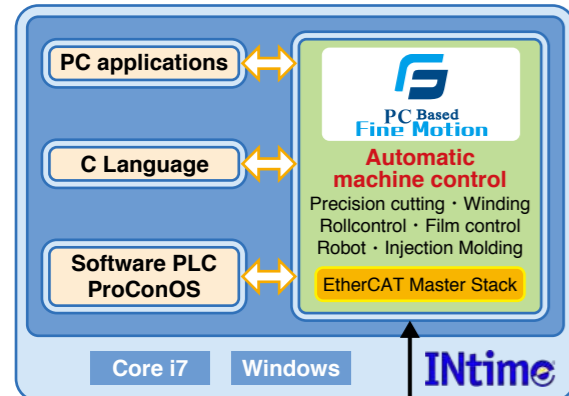

● Synchronous feed Synchronous follow

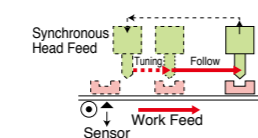

● Parallel axis control

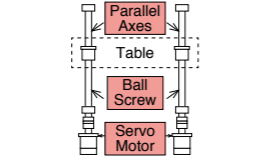

● Electric cam

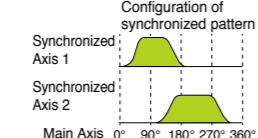

● Thread-cutting

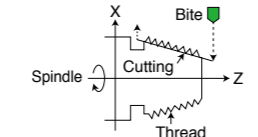

● Roll/Tension control

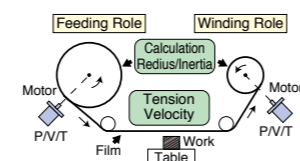

● DNC

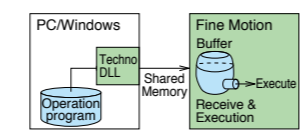

● Oscillation

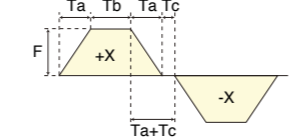

● Diameter compensation

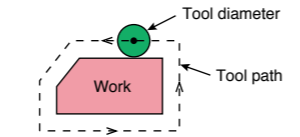

● Tangent control

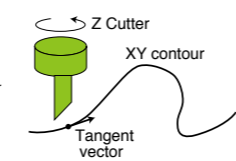

● High-precision position measurement

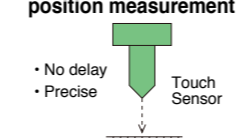

● Winding command

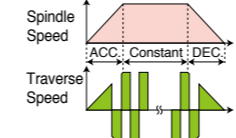

● Robot mechanism kinematics

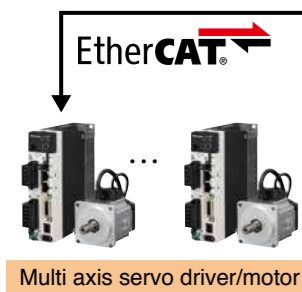
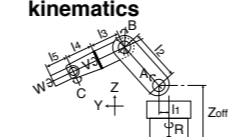

PC Based Motion Library

RTPL-EC

Features

- PC Based Motion Library is a motion development software for EtherCAT user. (Function group for various motion)
- In-house development of motion controller by C language with Visual Studio.
- Sample sources are prepared.
- High-speed operation with an efficient CPU. (0.25 msec/32-axis 0.5 msec/64-axis)
- High reliability by INtime, not depending on Windows. / High reliability by FAPC(Fanless/SSD)
- Easily operate from an application software on Windows.
- Easily cooperate with software such as image processing.



Specification

Example of Function Call Flow

- RtpIeCTInitializeLib ()
- RtpIeCTClearAlarm ()
- RtpIeCTServoON ()
- RtpIeCTLinInterpolate ()
- RtpIeCTCmdActive ()
- RtpIeCTResWait ()
- RtpIeCTServoOFF ()
- RtpIeCTCloseLib ()

PC Based Motion Library function

Library initialization	RtpIeCTInitializeLib();	Pause	RtpIeCTHoldAxis();
Library Close	RtpIeCTCloseLib();	Set Synchronous Axis	RtpIeCTSetGantryAxis();
Execute command	RtpIeCTCmdActive();	Set Override	RtpIeCTSetOverride();
Wait for Response	RtpIeCTResWait();	Return to origin	RtpIeCTHomePosition();
Monitor Status	RtpIeCTGetStatus();	Positioning	RtpIeCTPositioning();
SDO Write	RtpIeCTSetSDO();	Latch Positioning	RtpIeCTLatchPositioning();
PDO Write	RtpIeCTSetPDO();	Linear Interpolation	RtpIeCTLinInterpolate();
Servo ON	RtpIeCTServoON();	Circular arc Interpolation	RtpIeCTCircInterpolate();
Servo OFF	RtpIeCTServoOFF();	JOG Stop	RtpIeCTJOGStop();
Servo Alarm Clear	RtpIeCTClearAlarm();	Torque control start	RtpIeCTTorqueCtrlStart();

Application Sample

- Semiconductor-fabrication equipment
- Printing System
- Electronic equipment production line
- Other multi axis control devices

System Configuration

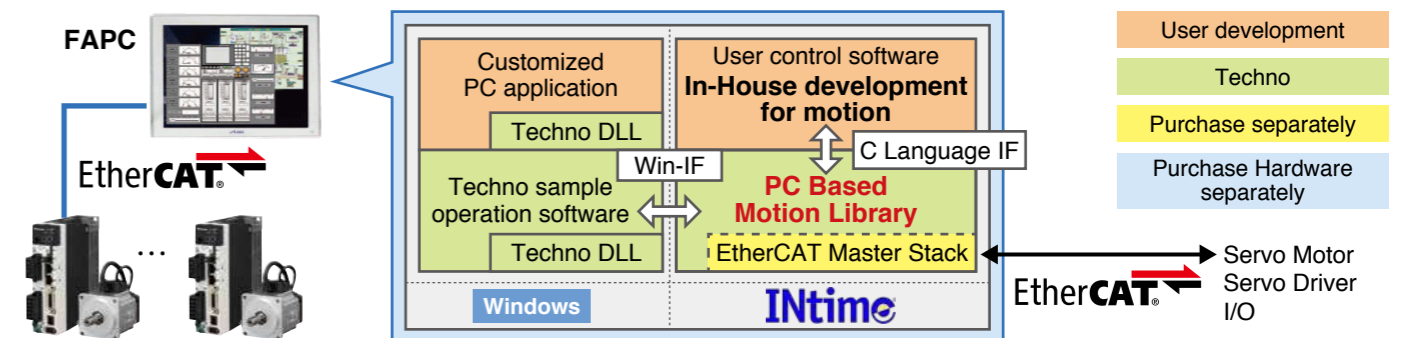

Sales area

• Japan • All over the world
Please contact the following address for details.

Language

• English
• Japanese

For more information

PC Based Fine Motion URL: <http://www.open-mc.com/products/pdt05.html>
PC Based Motion Library URL: <http://www.open-mc.com/products/pdt06.html>
INtime URL: <http://www.mnc.co.jp/INtime/>

Contact: **TECHNO Co., Ltd.**

1304-5, Shimo-fujisawa, Iruma-shi, Saitama, 358-0011, Japan

[E-mail: mail@open-mc.com]

TEL: +81-4-2964-3677 FAX: +81-4-2964-3322

Programmable Automation Controllers

Power Family

Features

All controllers of the **Power family** are equipped with 32 bit Risc (Reduced Instruction Set Computer) CPU to allow use of a sole **Real Time Multitasking Operative System (OS)** to manage PLC, CNC, HMI and IT tasks. The scale between the different models depends on:

- CPU with different clock (132 or 264 MHz) and cores (1 or 2)
- Memory architectures with different parallelism (16 or 32 bit)

The **compiler**, which generates the executable code, is integrated in the firmware of the controller so the system becomes completely autonomous and independent from the evolutions of the consumer world (PC) and **unaffected by computer viruses**.

There are two main executors, each one with its set of instructions:

- **PLC executor** which cycles continuously between the first and the last instruction of the PLC program
- **CNC executor** which starts only on request, it can be put on hold or deleted and it ends after the last instruction of the CNC program

CNC executor can process up to **5 CNC** task at the same time. Their execution are transferred in a buffer (**Look Ahead**) where they are processed to obtain effective trajectories of the interpolated axes. The commands inserted in ISO editor (the user program written in **G-code**) are interpreted and executed launching the execution of different blocks present in the BLC editor.

The OS manages many types of communication ports:

- **Ethernet** with the support of TCP/IP, FTP and ModbusTCP protocols; **OPC server** and **WEB server** are also available
- **RS232/RS485** serials with **Modbus** protocol (ASCII and RTU)
- **USB** which can connect **MSD** (Mass Storage Device) of different types and with more memory volumes, **HID** (Human Interface Device) like keypads / mouse and tracking devices like Gamepad

It can manage up to **28 axes** in point to point, gearing, camming and interpolation mode. Their trajectory can be shaped via many different levels of **Jerk** in order to reduce the inertial effect of load without great loses in performances.

Application Sample

- Plane cutting machines (Plasma, Laser, Oxy, Waterjet, Diamond disk)
- Stone working machines (Bridge saws, Polishing, CNC contouring)
- Woodworking machines (CNC for drilling, routing, tenoning, sawing)
- Metal machining (3-5 axes milling, parallel & automatic lathe turning)
- Textile (Cutting, Sewing, Labelling, Finishing & Washing)
- Pick & Place with Articulated, Cartesian, SCARA or DELTA robots
- Packaging and all sort of automatic machines

System Configuration

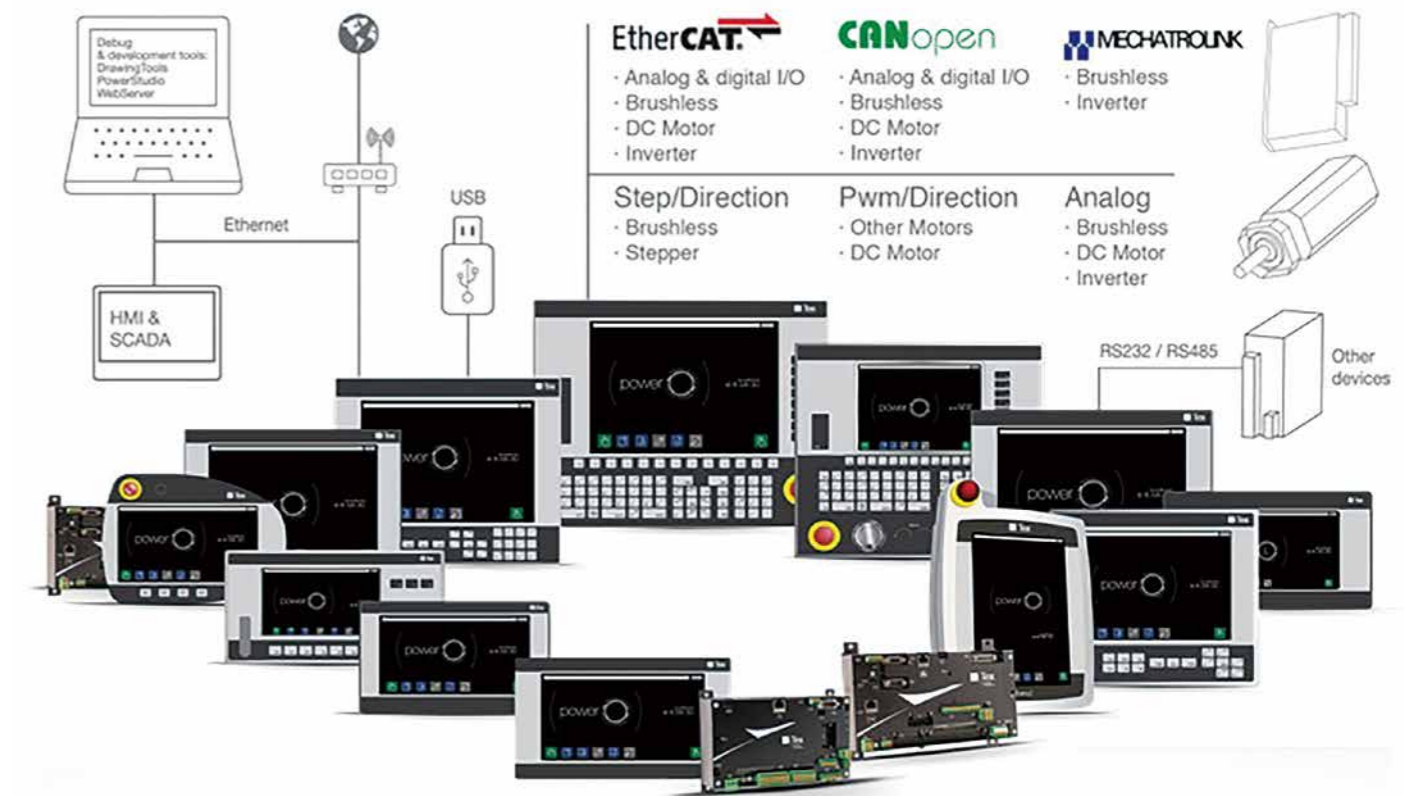

Sales area

- China
- India
- Brazil
- Europe

Language

- Italian
- English

Please contact us for details.

For more information

URL: www.texcomputer.com

Contact: **Tex Computer srl**

via Mercadante, 35 – 47841 Cattolica (RN) – Italy

TEL: +39 (0)541 832511 FAX: +39 (0)541 832519

Motion Coordinator and EtherCAT Interface Module

Motion Coordinator MC664 /MC664-X Panasonic EtherCAT Interface Module

Features

- Up to 128 Axes
- Servo period 50 µsec minimum (8 axes)
- Precise 64 Bit Motion Calculations with Quad Core Cortex A9 1 GHz Processor (P862)
- Dedicated Communications Core (P862)
- Built-in EtherCAT Port
- EtherCAT, Sercos, SLM and RTECH Digital Drive Interfaces
- Linear, Circular, Helical and Spherical Interpolation
- Flexible CAM shapes, Linked Motion
- EnDAT, BISS and SSI Absolute Encoder Supported
- Hardware Linked Outputs for Camera / Laser Control
- Ethernet-IP / Modbus TCP / Ethernet Interface Built-In
- Anybus-CC Module for Flexible Factory Comms Including ProfiNet/Profibus
- IEC 61131-3 Programming
- Multi-tasking BASIC Programming
- Text File Handling
- Robotic Transformations
- SD Memory Card Slot
- CANopen + EtherCAT I/O Expansion
- Backlit LCD Display
- RoHS and CE Approved



Specification

Item	Description	Item	Description	
MC664 / MC664-X				
Configuration	Axis 0	Encoder / Pulse out		
Axes	Max axes	128	Encoder Ports	
	Max discrete wired axes	24		
	Max Networked axes	128 (P862) 64 (P861)		
	Max virtual axes	128		
	Max networked axes	128		
Performance	Processor	ARM A9 (Quad)	Built-In I/O	
	Clock frequency	1000 MHz (Max)		
	Servo update rate	2 ms (4 ms = MC664) -50 µs (8 axes at 50 µs)		
	Encoder input frequency	6 MHz		
	Stepper output frequency	2 MHz		
	User memory	8 Mbyte	Expansion I/O	
	Max data table size	512000		
	Flash data memory	32 x 16000		
	VR	65536		
	Position register precision	64 bit		
	Drive Interfaces	Maths precision	Double FP	Programming
		Real time clock	Yes	
		Stepper (Step & Direction)	Option	
		Servo (±10 V & Encoder)	Option	
		Piezo	Option	
Communication	Panasonic RTECH	Option	Software	
	Hydraulic	Option		
	EtherCAT	YES/Option		
	Profibus	Option		
	DeviceNet	Yes (slave)		
	Expansion	CANopen	Yes (server)	Physical
		USB (V1.1)	Option	
		Ethernet (10/100) base-T	Yes	
		Ethernet IP	Yes (server)	
		MODBUS-RTU	Yes	
	Power	MODBUS-TCP/IP	Yes	Certification
		RS232/RS485	Yes	
		CC-Link	Option	
		ProfiNet	Option	
		Bluetooth	Option	
Certification	Anybus support	Option	CE approval	Yes
	Hostlink	Yes	RoHS Compliant	Yes

Item	Description
EtherCAT Interface Specification	
Max Slaves per chain	128
Cable	Cat 5e or better
Regist Inputs	8 x 24 V
Supported modes	CSP, CSV, CST, Open speed
Axis Feature Enable Codes	P914

Application Sample

URL : Sample applications

<http://www.triomotion.uk/public/applications/applications.php>

Please refer to the sample and typical applications for the MC664 with A6B as shown above URL.

System Configuration

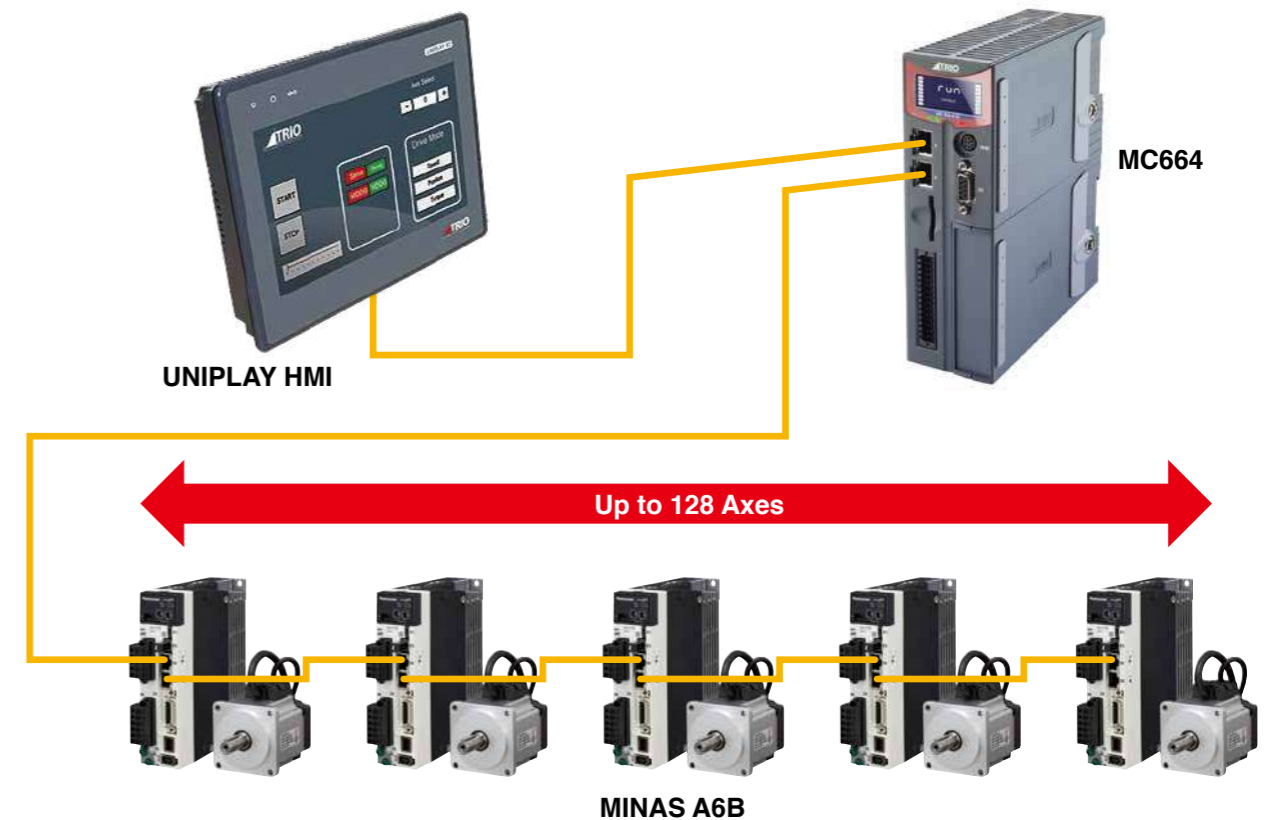

Sales area

- United Kingdom
- United States of America
- China
- India

Language

- English

Please contact the following address for details.

For more information

URL: Specification for the MC664 / MC664-X

<http://www.triomotion.uk/public/products/p862.php>

Contact: **Trio Motion Technology Ltd.**

Shannon Way, Tewkesbury, Gloucestershire, GL20 8ND, United Kingdom TEL: +44-1684-292333 FAX: +44-1684-297929

Motion Coordinator and EtherCAT Interface Module

Motion Coordinator MC6N-ECAT

Features

- Up to 64 EtherCAT Digital Drive Axes
- Supports Position, Speed and Torque Drive Modes
- Up to 1024 EtherCAT I/O
- EtherCAT CoE, SoE, FoE
- Linear, Circular, Helical and Spherical Interpolation
- Flexible CAM shapes, Linked Motion
- Isolated Encoder Port
- EnDAT and SSI Absolute Encoder Supported
- Hardware Linked Output for Camera / Laser Control
- Ethernet-IP / Modbus TCP / Trio ActiveX / TCIP/ Uniplay HMI / UDP / Ethernet Interface Built-In
- 1GHz i.MX7 Dual ARM Cortex A7 Core Process
- IEC 61131-3 Programming
- Multi-tasking BASIC Programming
- Text File Handling
- Robotic Transformations
- 4 high speed registration inputs
- Isolated RS232 and RS485 ports
- SD Memory Card Slot
- EtherCAT I/O Expansion
- CANopen I/O Expansion
- Backlit LCD Display
- RoHS and CE Approved



Specification

Item	Description	Item	Description	
MC4N-ECAT				
Configuration	Axis 0	Extended		
Axes	Max axes	64	Built-in I/O	
	Networked axes	64		
	Max virtual axes	64		
Performance	Processor	i.MX7 Dual ARM Cortex A7 Core		Inputs 24 VDC
	Clock frequency	1 GHz	Bi-directional I/O 24 VDC	
	Servo update rate	2 ms-125 µs	# registration inputs	
	Encoder input frequency	6 MHz	Registration input speed	
	Stepper output frequency	2 MHz	WDOG output	
	User memory	8 MByte	Expansion I/O	Digital I/O points
	Max data table size	512000		12 bit ±10 V analogue inputs
	Flash data memory	32 × 16000		12 bit ±10 V analogue outputs
	VR	4096	Programming	TrioBASIC
	Position register precision	64 bit		# programs
	Maths precision	Double FP		# tasks
	Real time clock	Yes		IEC61131 Runtime
	Drive Interfaces	EtherCAT		Yes
Auxiliary Axis		Yes		G-Code
Communication	DeviceNet	Yes (slave)		HPGL
	CANopen	Yes (master)	DXF import	
	Ethernet (10/100) base-T	Yes	Software	Motion Perfect v4
	Ethernet IP	Yes (server)		All Support Software
	MODBUS-RTU	Yes	Expansion	Memory slot card
	MODBUS-TCP/IP Client	Yes		Width × Height × Depth (mm)
	RS232/RS485	Yes	Physical	Weight
	Hostlink	Yes		Mounting
Encoder Ports	Reference input	Yes		Operating Temp
	Pulse + direction output	Yes	Power	Supply Voltage DC
	Incremental (A+B) output	Yes		Consumption (exc. I/O)
	SSI Absolute	Yes	Certification	UL Listed
	EnDat Abs	Yes		CE approval
			RoHS Compliant	

Application Sample

URL : Sample applications

<http://www.triomotion.uk/public/applications/applications.php>

System Configuration



Sales area

- United Kingdom
- United States of America
- China
- India

Language

- English

Please contact the following address for details.

For more information

URL: Specification for the MC4-N ECAT Mini Master

<http://www.triomotion.uk/public/products/p900.php>

Contact: **Trio Motion Technology Ltd.**

Shannon Way, Tewkesbury, Gloucestershire, GL20 8ND, United Kingdom TEL: +44-1684-292333 FAX: +44-1684-297929

Motion Coordinator and EtherCAT Interface Module

Motion Coordinator PC-MCAT Ethercat Master

Features

- Motion + PC Solution for Automation Machinery
- Fanless compact PC with E3845 Quad Core Atom Processor at 1.91 GHz
- Powerful up to 64 Axis EtherCAT Based Trio Motion Coordinator
- RTX64 Real Time Extension to allow Motion + Windows Running Directly on Their Own Processor Cores
- Plug and Play EtherCAT Configuration Expandable Support for Servo Drives, I/O and Devices From Over 100 Manufacturers
- Programmable In Easy Trio BASIC, built-in IEC 61131 or PC based Programming Languages Such As Ladder
- 4 GByte RAM + 64 GByte Upgradable SSD
- Windows Operating System
- Built-in Additional GBit Ethernet Port For Vision Cameras



Specification

Item	Description
PC-MCAT	
Motion Axes	2 / 4 / 8 / 16 / 32 / 64
Servo Cycle	250 / 500 / 1000 / 2000 μsec
Drive Modes	Position / Speed / Torque
Interpolation	Linear / Circular / Helical / Spherical / Transition Curves / Tangential
Linked Modes	Cam, Cambox, Flexlink, Movelink, Camlink

EtherCAT Specification	
Speed	100 Mbps
Physical Layer	100BASE-TX full duplex (IEEE 802.3)
Cable	Shielded Twisted Pair (TIA/EIA-568B CAT5e)
Topology	Line, tree or star
Isolation	Pulse transformer with common-mode choke
Connector	RJ45
Cable Length	100 m max between nodes
Cyclic period	250 μsec, 500 μsec, 1000 μsec or 2000 μsec
Synchronisation	Distributed Clocks technology. Jitter <1 μsec
Protocol	CoE, SoE
Number of Axes	64
Number of Nodes	128 slave nodes maximum
Motion modes	Cyclic Synchronous Position, Cyclic Synchronous Velocity, Cyclic Synchronous Torque
Parameter transfe	CoE Object read/write. SoE IDN read/write
In put/Ou tput	Up to 8192

PC Specification	
Processor	Intel® Atom™ E3845 Quad Core 1.91 GHz
Memory	4 GBytes DDR3
Ethernet	2 x Gb Ethernet + EtherCAT port
HDMI	2560 x 1600 @ 60 Hz Max
Audio	Via HDMI
USB	5 USB ports
Battery	8 Year life PLC compatible type. Replaceable without opening case.
Power Supply	24 V +/-20 % Isolated Power Supply
Operating Temp	0 deg – 55 deg C
Cooling	Fanless
Operating System	Windows with RTX64 Real Time Extension

Application Sample

URL : Sample applications

<http://www.triomotion.uk/public/applications/applications.php>

System Configuration

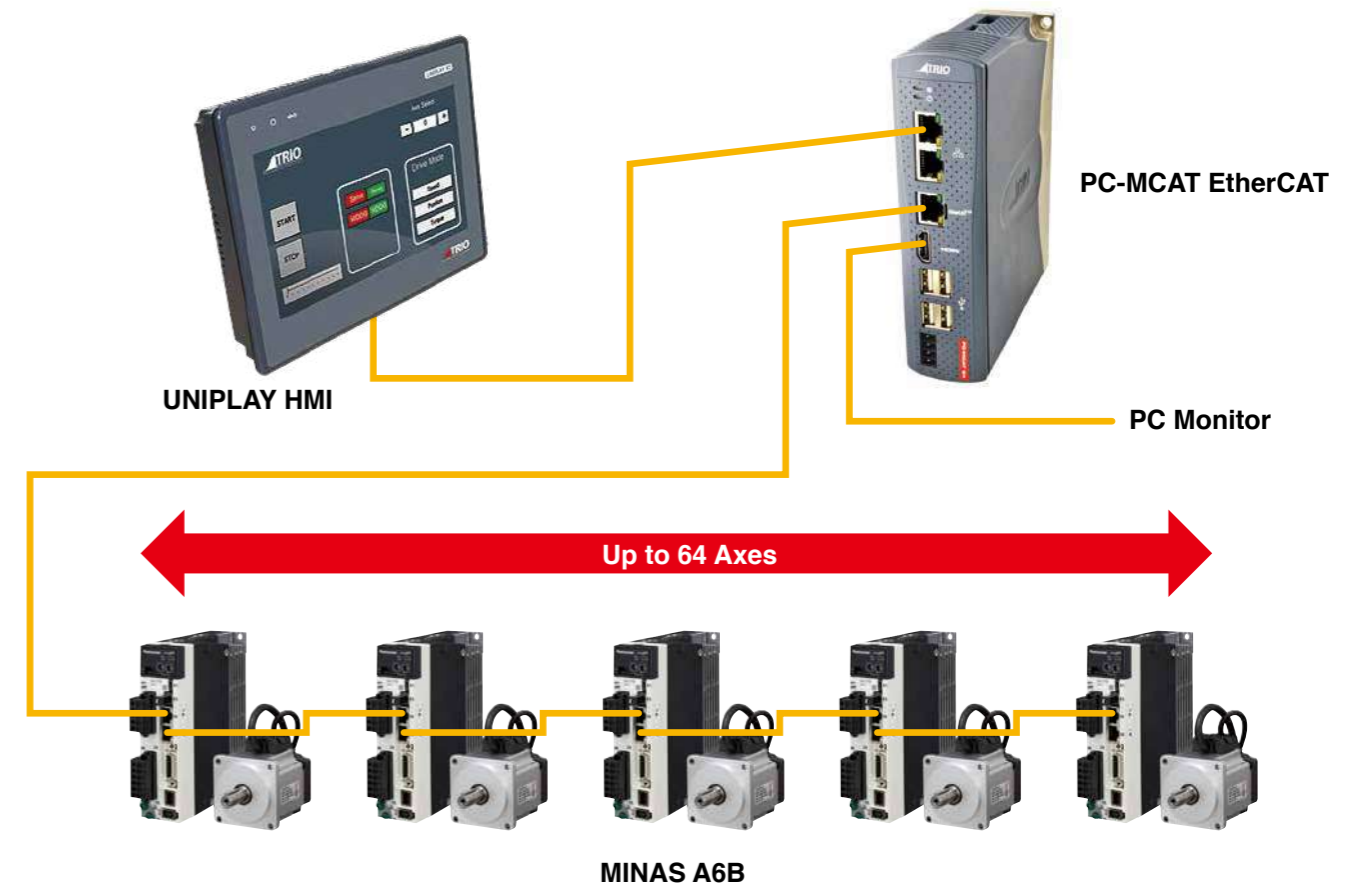

Sales area

- United Kingdom
- United States of America
- China
- India

Language

- English

Please contact the following address for details.

For more information

URL: Specification for the PC-MCAT Ethercat Master

<http://www.triomotion.uk/public/products/p760.php>

Contact: **Trio Motion Technology Ltd.**

Shannon Way, Tewkesbury, Gloucestershire, GL20 8ND, United Kingdom TEL: +44-1684-292333 FAX: +44-1684-297929

Corresponding table

Partner	Master					
	Software	PC Board	IPC	Panel PC	Stand Alone	PLC
Panasonic Corporation						●
acontis technologies GmbH	●					
ADLINK Technology, Inc.			●			
Advanet Inc.		●				
Advantech Co., Ltd.		●				
ALGO System Co.,Ltd			●	●		
Beckhoff Automation GmbH & Co.KG	●		●	●		●
CODESYS	●					
CONTEC Co., Ltd.			●			
FAGOR AUTOMATIO					●	
Galil Motion Control, Inc.		●				
Hivertec, Inc.	●					
Hypertherm, Inc.					●	
ISAC	●				●	
Leadshine Technology Co., Ltd.						
Micronet Company	●		●	●		●
Mujin, Inc.					●	
National Instruments Corporation					●	
NEXCOM International Co., Ltd.			●			
Soft Servo Systems, Inc.	●					
TECHNO Co., Ltd.	●					
Tex Computer srl					●	
Trio Motion Technology Ltd.					●	

Area with horizontal dashed lines for notes.

Linear and direct drive (DD) motor control

MINAS A6L series Manufacturer/ Distributor: Panasonic Corporation

A6SL, A6SM

High-precision and high-speed advancement of linear motor / direct drive motor control driver inheriting the basic control performance of the A6 series



Motor

- Various motors such as 3-phase cored/coreless, shaft motor and DD motor

Scale

- Serial communication incremental/absolute and A/B/Z phase pulse scale

Magnetic pole detection

- Both with and without hole sensor signal (automatic detection)

Setup

- Automatic setup of magnetic pole, scale direction, gain, etc.

[Typical system configuration]

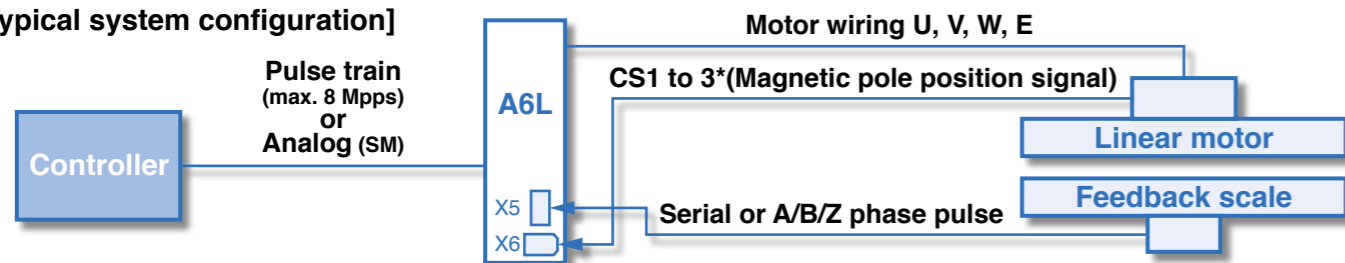

[Setup] • Please ask us to get this software.

* Connection is unnecessary when magnetic pole is automatically detected.

Automatic Setup

Automatically sets various parameters such as magnetic pole, scale orientation and gain accordingly to the motor specification.

Drastically reduced setup time.

Automatic Magnetic Pole Detection

When CS signal is not available, the automatic magnetic pole detection function will detect the magnetic pole position of the linear motor.

Short adjustment time without magnetic pole sensor

Simple setup for easy and speedy adjustment

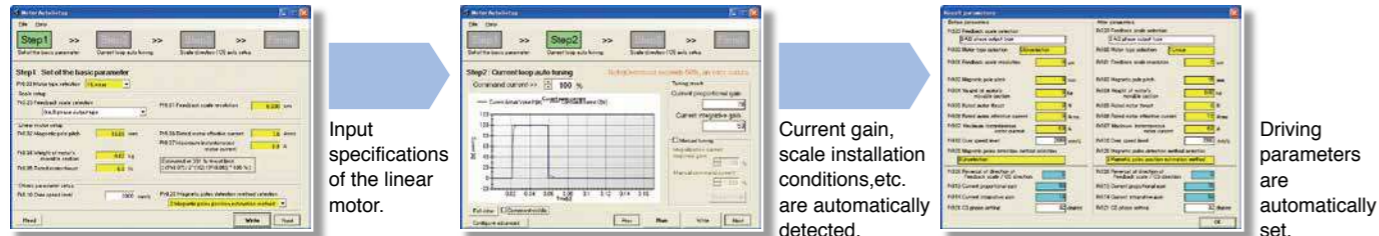

[Lineup]

	SM [Standard]	Specifications	SL [Pulse and I/O input only]
	Position, speed and thrust command, Block operation	Instruction	Position command, Block operation
	Capable	Two-degree-of-freedom control	Capable
	Capable	RS232, RS485	Capable
	Compliant	Safety function (STO)	N/A
	Capable	Analog input	N/A

A6NL RTEX compatible linear control driver



- Two-axis integrated type is also available. For details, refer to the specifications.

A6BL EtherCAT compatible linear control driver



[Typical system configuration] For linear motor

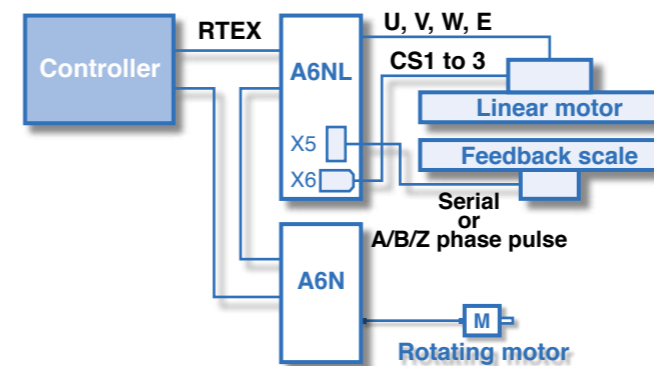

[Typical system configuration] For linear motor

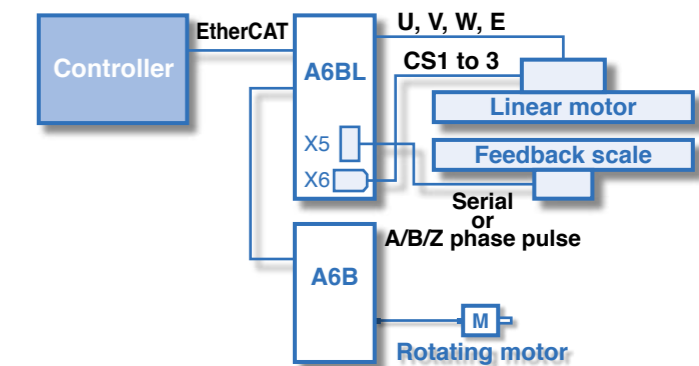

Drive List

Power supply	Drive Part No. (Note 1)	Motor rated current [Arms] (Note 2)	Motor max. current [Arms] (Note 2)	
1-phase 100 to 120 VAC	MADL□01△△	1.1	3.7	
	MADL□11△△	1.6	5.5	
	MBDL□21△△	2.5	7.4	
	MCDL□31△△	4.6	14.3	
1-phase or 3-phase 200 to 240 VAC	MADL□05△△	1.1	3.8	
	MADL□15△△	1.5	4.8	
	MBDL□25△△	2.4	7.3	
	MCDL□35△△	4.1	13.2	
	MDDL□45△△	5.2	15.5	
3-phase 200 to 240 VAC	MEDL□83△△	12.5	37.4	
	MEDL□93△△	16	48	
	MFDL□A3△△	18.1	54.4	
	MFDL□B3△△	27.1	72.1	
	MGDLTC3△△	44	116.6	
	MHDLTE3△△	66.1	167.2	
	MHDLTF3△△	80.2	207.9	
	3-phase 380 to 480 VAC (Under development)	MDDL44△△	1.5	4.5
		MDDL54△△	2.9	8.7
		MDDL64△△	4.7	14.1
MEDLT84△△		6.7	19.7	
MFDLTA4△△		9.4	28.2	
MFDLTB4△△		16.5	42.4	
MGDLTC4△△		22	58.7	
MHDLTE4△△	33.1	83.7		
MHDLTF4△△	40.1	103.9		

Note 1: Please refer to "□" and "△△" as per below ;

- □ Common N : Without Safety)
T : With Safety STO)
- △△ A6L SM : Full Version)
SL : Only Pulse control)
A6NL NM : Multi-function type
NL : Standard type
A6BL BM : Multi-function type
BL : Standard type

There are restrictions on combinations. Multi-function type (M suffix is M) has safety function (T in the 5th digit of model number), Position control type, standard type (L at the end of the model number) No safety function (5th digit in the model number is N).

Note 2: According to the setting value of carrier frequency, we have the possibility of derating. In detail, please refer to the A6L driver specification.

Linear and direct drive (DD) motor control

MINAS A6L series

Drive appearance

A6SM size A

* This photo shows multi-functional type. The position control type does not have an X3 connector.

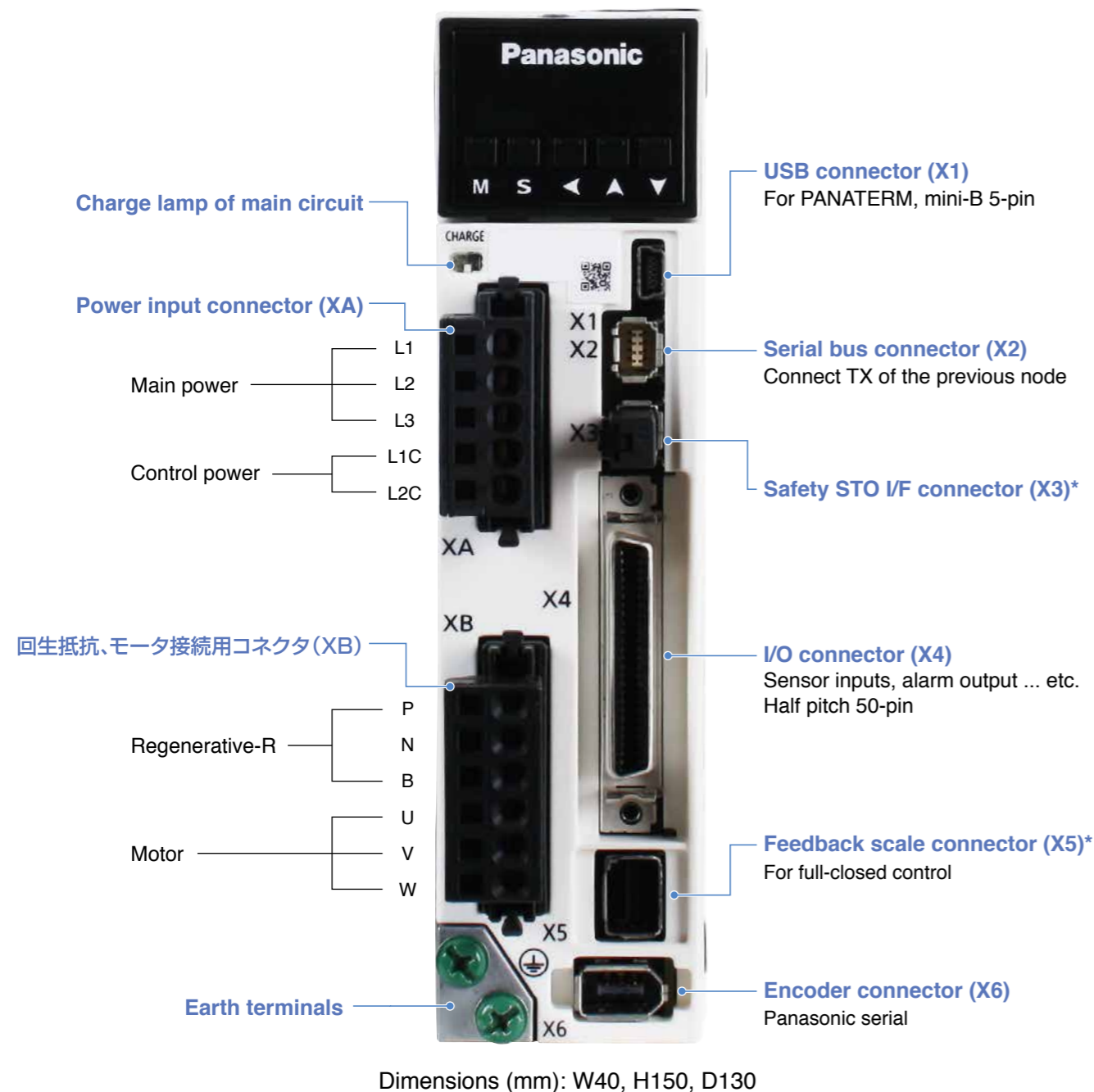

Low voltage small servo MINAS A5ML, A5MNL, A5MBL (DC24 V/48 V)

• This product is not A6, but A5M series for specific customers. For more details, refer to the specifications.

Drive appearance

A5ML

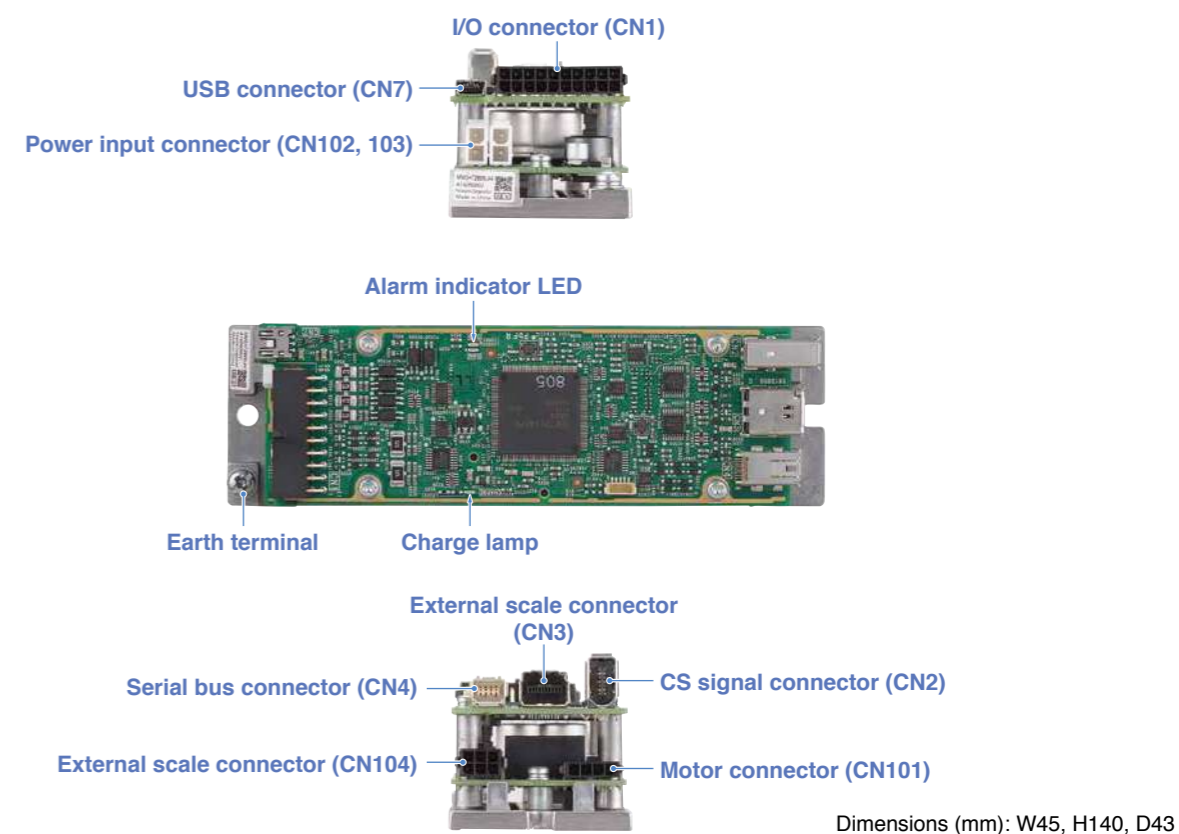

List of drivers

Driver power	I/F	Series	Driver model number	Motor rated current [Arms] ^{*1}	Motor maximum current [Arms] ^{*1}
DC 24 V	Pulse train	A5ML	MMDHT2C09LA4	2.8	7.5
	RTEX	A5MNL	MMDHT2C09NL1		
	EtherCAT	A5MBL	MMDHT2C09BL1		
DC 48 V	Pulse train	A5ML	MMDHT2B09LA4	2.2	6.5
	RTEX	A5MNL	MMDHT2B09NL1		
	EtherCAT	A5MBL	MMDHT2B09BL1		

*1 According to the setting value of carrier frequency, we have the possibility of derating. In detail, please refer to the A6L driver specification.

Direct Drive Rotary Motor

ADR Series / ACD Series / AXD Series / ACW Series / AXM Series

Features

- Direct drive. Brushless motor fully integrated with encoder and bearing.
- Preparing multiple series using Akribis's patented * technology for stator design. Available for semi-custom.

ADR (A/B/F) Series :

The own stator design realizes low cogging while maintaining high torque. Multiple center holes can be selected and a small build-in type is available.

ACD Series :

Coreless stator design realizes zero-cogging with direct drive mechanism.

AXD Series :

Despite its small size, this series achieve the highest torque in the same range. This series have flat design and large center hole through unique mechanical design.

ACW Series :

37mm thinnest type. Zero-cogging design.

[New] AXM Series :

Smaller series than ACD series.

* Including patent applying

Line up

ADR-A Series

Standard type

- Through our unique winding design, our ADR-A series have high slot fill factor and produce very high torque.
- Rated torque : min. 1.9 N·m to max. 477.9 N·m
- Encoder can be optionally customized

ADR-B Series

Bigger center hole type

- ADR series common high torque and low cogging design
- Bigger center hole series than ADR-A series.
- Rated torque : min. 1.9 N·m to max. 94.9 N·m
- Encoder can be optionally customized

ADR-F Series

Built-in type

- Line-up of small build-in type that are rarely handled in the market 45 mm to 90 mm
- For flexible design
- Low cogging design



ACD Series

Zero-Cogging type

- Magnetic attraction that causes cogging is eliminated by not forming a core in the stator, and it realizes zero-cogging.
- High response performance

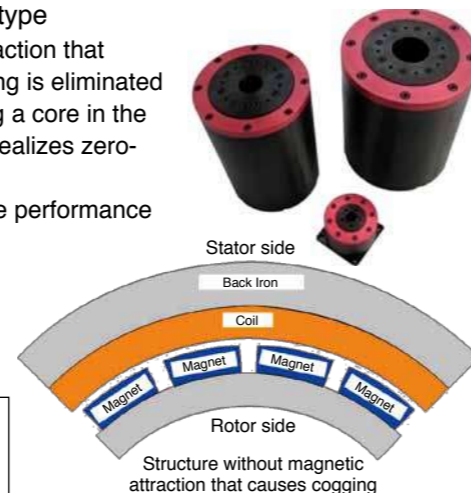

Recommended A6L series driver :

For the recommended driver, refer to the page of A6L series and select the part number with the optimum current value. Please contact us for details.

AXM Series

- Smaller size series than ACD series.
Min. diameter 80 mm
- High Torque, compact size
AXM40 : Diameter 40 mm
AXM60 : Diameter 60 mm
- Low cogging



ACW Series

Flat type

- Low profile, Large Center hole
- High precision control
- Zero-cogging design
- Center hole size $\phi 37$ mm to 70 mm



[New] AXD Series

- High torque, compact size,
- Large center hole, and low cogging
- High resolution optical encoder feedback



Specification

		ADR-A Series	ADR-B Series	ADR-F Series	ACD Series	AXM Series	ACW Series
Table diameter	mm	110 to 360	110 to 220	45 to 90	62 to 120	40 to 60	120 to 220
Table height	mm	75 to 215	113 to 217	14.0 to 58.5	60 to 175	43 to 50	37 to 42
Number of poles		16 to 32	16 to 24	14 to 16	8 to 12	-	16
Continuous torque	N·m	1.9 to 377.9	1.9 to 94.9	0.05 to 3.75	0.115 to 9.216	0.12 to 0.68	0.6 to 10.3
Peak torque	N·m	5.8 to 1133.8	5.8 to 284.6	0.15 to 11.26	0.40 to 32.25	0.35 to 2.03	2.1 to 35.9
Max. Cogging torque (peak to peak)	N·m	0.0024 to 4.090	0.002 to 0.736	4.16E-04 to 1.10E-02	0	low cogging torque	0
Continuous current	Arms	3.0 to 20.0	3.00 to 16.20	0.60 to 13.40	2.8 to 5.1	1.25 to 3.00	5.0
Peak current	Arms	9.0 to 60.0	9.00 to 48.60	1.80 to 40.20	9.7 to 17.9	3.75 to 9.00	17.5
Motor constant	N·m/ Sqrt(W)	0.36 to 16.90	0.36 to 5.47	0.04 to 0.61	0.028 to 0.901	0.027 to 0.103	0.10 to 0.91
Rotor inertia	kg·m ²	0.0003086 to 0.322304	0.000309 to 0.025216	2.60E-06 to 2.04E-04	0.0000216 to 0.0032075	0.0000118 to 0.0000738	0.000658 to 0.008354
Max speed @230 V AC (DIGITAL)	r/min	30 to 1200	50 to 1200	-	-	-	300 to 400
Resolution (at 64X interpolation)	Counts/rev	192320 to 480000	192320 to 324544	-	103680 to 183552	-	251776 to 480000
Resolution (at 512X interpolation)	Counts/rev	1538560 to 3840000	1538560 to 2596352	-	829440 to 1468416	-	2014208 to 3840000
Resolution (at 4096X interpolation)	Counts/rev	12308480 to 30720000	12308480 to 20770816	-	6635520 to 11747328	-	16113664 to 30720000
Accuracy	arc sec	± 20 to ± 30	± 20 to ± 25	-	± 30	-	± 30
Repeatability	arc sec	± 2 to ± 2.7	± 2 to ± 2.7	-	± 3	± 10	± 3
Axial runout	μ m	15 to 40	15 to 25	-	12 to 15	25	Max.15 to 18
Radial runout	μ m	15 to 40	15 to 25	-	10	25	Max.15 to 18
Max axial load	N	700 to 11200	439 to 1669	-	10 to 150	6 to 15	150.0 to 300.0
Max moment load	N·m	20 to 245	25 to 85	-	10.0	0.1 to 0.2	14.7 to 55.2

Sales area

- Singapore • Malaysia • Thailand • China
- Taiwan • Korea • Japan
- USA (Silicon Valley) • USA (Boston) • Germany • Israel

Language

- English • Japanese • Chinese
- Korean • Thai

For more information

URL: <http://www.akribis-sys.com/>

Contact: **Akribis Systems Pte Ltd**

5012 Techplace II Ang Mo Kio Ave 5 #01-05 Singapore 569876

[E-mail: cust-service@akribis-sys.com]

TEL: +65-6484-3357 FAX: +65-6484-3361

Voice Coil Motor & Single - Axis Actuator

AVM Series / AVA Series

Features

- Compact, cogging and backlash less, enabling high speed operation and high accuracy positioning
- Smooth operating at low speed
- Line up : Cylindrical type for standard, High power and customized model
- Flat type is also prepared for flexible application
- Support semi custom such as hole diameter change and screwing

Specification

Cylindrical Type Voice Coil Motor AVM Series



		AVM series (9 types)	AVM-HF (High Force) series (9 types)	AVM Custom series (19 types)
Diameter D	mm	12.7, 19, 20, 24, 30, 40, 60, 90	35, 40, 50, 60, 90, 100, 130, 250	14.2, 20, 24, 30, 35, 40, 50, 75, 80, 90, 130, 150
Stroke	mm	5 to 30	6.5 to 25	4 to 38
Force sensitivity at mid stroke	N/A	0.57 to 22.50	16.00 to 168.40	0.82 to 97.63
Back EMF constant	V/(m/s)	0.57 to 22.50	16.00 to 168.40	0.82 to 97.63
Continuous force (at 100°C)	N	0.91 to 89.10	14.40 to 1111.44	0.98 to 585.77
Peak force	N	3.53 to 315.00	72.00 to 4715.20	2.95 to 1757.30
Continuous current (coile at 100°C)	A	0.63 to 3.96	0.80 to 6.60	0.70 to 6.00
Peak current	A	3.80 to 14.00	4.50 to 28.00	3.60 to 18.00
Max coil temperature	°C	100		
Coil assembly mass	g	5.0 to 820.0	53.0 to 5900.0	3.0 to 1500.0

Planar Type Voice Coil Motor AVA Series



		AVA1-20	AVA2-20	AVA3-20
Stroke	mm	20	20	20.0
Force sensitivity at mid stroke	N/A	1.92	8.35	9.40
Back EMF constant	V/(m/s)	1.92	8.35	9.40
Continuous force (at 100°C)	N	3.84	11.69	26.32
Peak force	N	11.5	35.1	79.0
Continuous current (coile at 100°C)	A	2.00	1.40	2.80
Peak current	A	6.0	4.2	8.4
Max coil temperature	°C	155.0		
Coil assembly mass	g	17.0	45.0	72.0

Line up for Voice Coil Motor Single - Axis Actuator • Stage

- Prepare the actuator and stage for the target application as a standard product.
- Simply connecting to the servo driver enables easy system integration.

Single-axis actuator



Cross roller • Bearing



Z-axis • W guide



Hollow • Cross roller



* Please consult us about applicable type number of servo driver.

Linear Motor

AUM Series / AJM, AQM, AKM Series / ACR Series

Features

- Wide range product
Coreless, zero cogging type (AUM series), vacuum compatible type (AWM series) and so on.
- Coreless type uses a special winding method that eliminates the dead zone between the coils. Compared to the same size linear motor, higher force and motor constant are achieved.
- Prepare standard modules with encoder and guide.
- AJM, AQM and AKM series
- Newly ACR series is developed as a curved large diameter linear motor

Ironless Type Linear Motor AUM Series / AHM Series (High Force Type)

- Unique winding technology achieves top level force and motor constant with the same size and keeping the coil length short
- Prepare standard modules with encoder and guide.

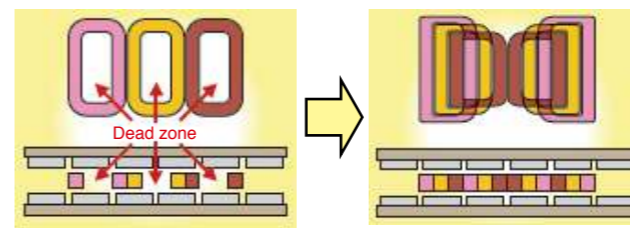

In addition, there are single-axis and multi-axis stage for various applications. Customized design is also available.



Sales area

- Singapore • Malaysia • Thailand • China
- Taiwan • Korea • Japan
- USA (Silicon Valley) • USA (Boston) • Germany • Israel

Language

- English • Japanese • Chinese
- Korean • Thai

For more information

URL: <http://www.akribis-sys.com/>

Iron Core Type Linear Motor

- AJM, AQM and AKM series
- Higher force and low price



ACR Series

- The large diameter ACR series is a new curved linear motor. Limit angle and 360° type are available.



Contact: **Akribis Systems Pte Ltd**

5012 Techplace II Ang Mo Kio Ave 5 #01-05 Singapore 569876

[E-mail: cust-service@akribis-sys.com]

TEL: +65-6484-3357 FAX: +65-6484-3361

Direct drive linear motor

LMA series, LMG series, LMS series, ILF+ series, ILM+ series

Features

IRON CORE LINEAR MOTOR

- LMA series – high continuous force
- LMG series – compact design and high peak force
- LMS series – compact design and high continuous force
- Speed up to 15 m/sec
- Peak force 273 N – 3640 N

<Typical example>

	Peak current/ Continuous current	Continuous force
LMA11-030-3TA	20.5 Arms/3.98 Arms	175 N
LMA11-030-3WTA	40 Arms/7.72 Arms	174 N
LMG05-030-3QA	17.2 Arms/2.56 Arms	66.6 N
LMS05-030-3QA	16.3 Arms/2.13 Arms	82.8 N
LMS05-030-3TA	30.6 Arms/4.10 Arms	84.5 N

IRON CORELESS LINEAR MOTOR

- ILF series – very low mass glider
- ILM series – compact design and high peak force
(Option: forced air cooling)
- Peak force 98 N – 3200 N
- Zero force ripple

<Typical example>

	Peak current/ Continuous current	Continuous force
ILM03-040-3RA	14.3 Arms/2.33 Arms	72.5 N
ILM03-040-3UA	29.8 Arms/4.80 Arms	71.6 N
ILF03-030-3NA	7.11 Arms/1.3 Arms	20.1 N
ILF03-030-3KA	3.5 Arms/0.638 Arms	20.1 N

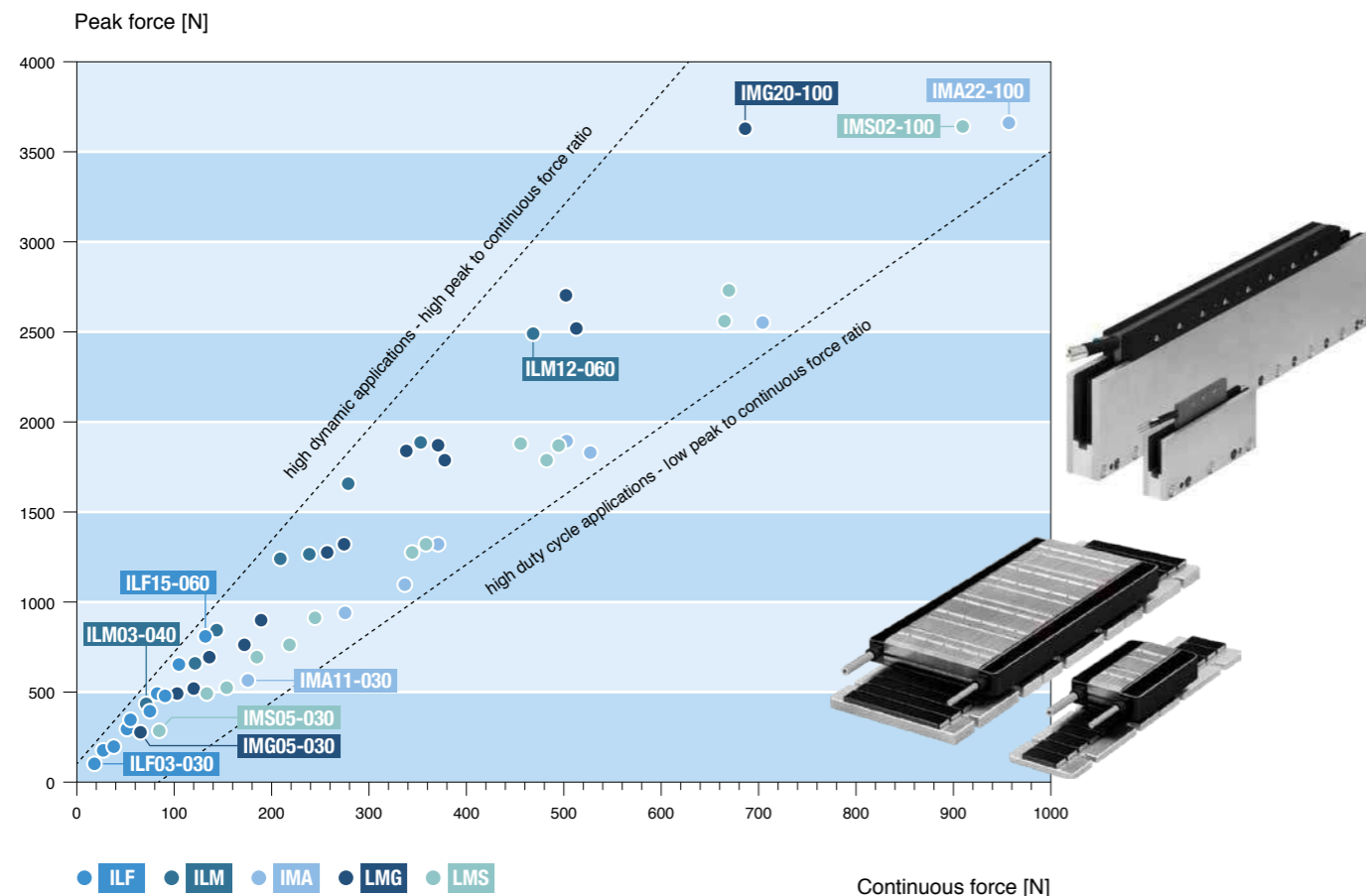

Direct drive torque motor

TMB+ series, TMK series

Features

TMK

- Large hollow shaft – up to 800 mm
- Peak torque – up to 20800 Nm
- Maximum rated speed – 5450 min⁻¹
- Liquid cooling channels

<Typical example>

	Peak current/ Continuous current	Continuous torque
TMK0291-050-3VBS	75.6 Arms/32.5 Arms	271 Nm
TMK0291-050-3VDS	151 Arms/64.9 Arms	271 Nm
TMK0291-070-3VBS	75.6 Arms/33.4 Arms	386 Nm
TMK0291-070-3VDS	151 Arms/66.7 Arms	386 Nm

TMB+

- Large hollow shaft – up to 1070 mm
- Peak torque – up to 42900 Nm
- Maximum rated speed – 4590 min⁻¹
- Liquid cooling channels

<Typical example>

	Peak current/ Continuous current	Continuous torque
TMB+0291-030-SA	17.3 Arms/6.32 Arms	137 Nm
TMB+0291-030-SB	34.5 Arms/12.6 Arms	137 Nm

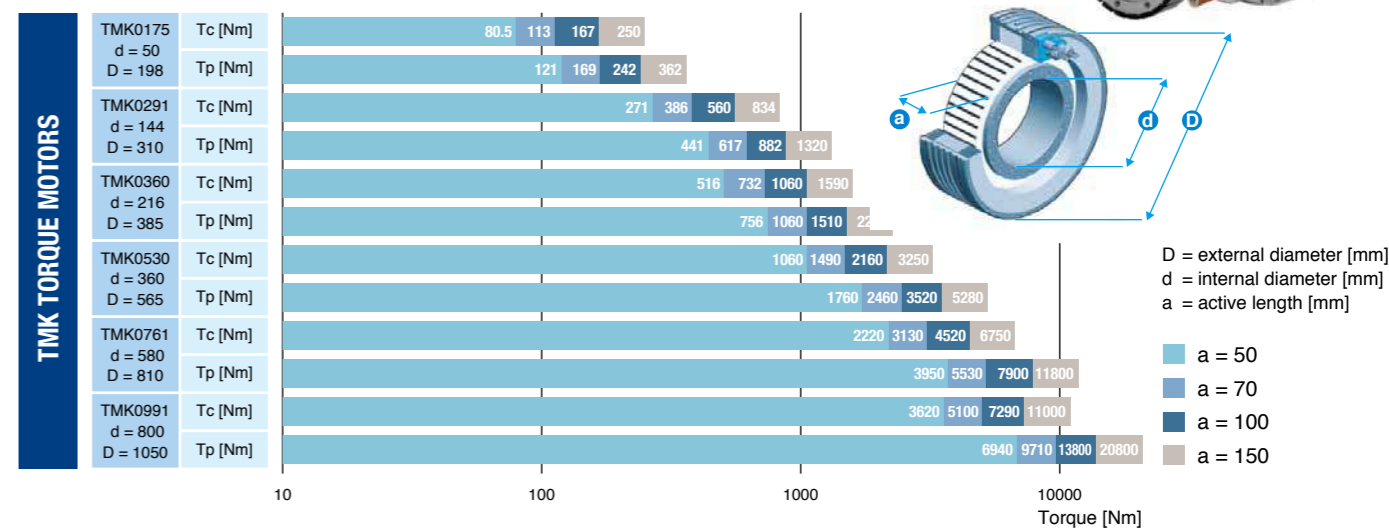

Sales area

- Japan
- United States of America
- German
- China
- Worldwide response

Language

- English
- German
- Japanese
- Chinese

For more information

URL : <https://www.etel.ch>

Contact: **ETEL S.A.**

Zone Industrielle CH-2112 Môtiers Switzerland

[E-mail: etel@etel.ch]

TEL: +41 (0)32 862 01 00 FAX: +41 (0)32 862 01 01

Direct Drive Rotary Motor

JTR series

Features

- High precision indexing rotary table
- Minimal cogging design
- High resolution and high torque
- Flexibility in division of angles and control of rotating direction and speed



Specification

PERFORMANCES	UNIT	JTR15T	JTR25T	JTR11 series		JTR15 series				JTR16 series		
				JTR1106	JTR1112	JTR1501E	JTR1503E	JTR1505E	JTR1508E	JTR1604	JTR1608	
Continuous Torque	N·m	1.4	9	2	4	5.3	10.7	18.1	28.8	14	27	
Peak Torque	N·m	4.2	27	6	12	15.9	32.1	54.3	86.4	40	80	
Continuous Current	A _{rms}	1.2	1.1	1.1		1.8	3.7				4.3	9
Peak Current	A _{rms}	3.5	3.3	3.3		5.5	11.1				12.9	27
Torque Constant	N·m/A _{rms}	1.2	8.2	1.8	3.6	2.9	2.9	4.9	7.8	3.3	3	
Motor Constant	N·m/W ^{1/2}	0.3	1	0.4	0.6	0.8	1.3	1.9	2.6	1.4	1.9	
Thermal Resistance	°C/W	3.32	1.22	3.72	2.14	2.26	1.41	1.07	0.73	0.87	0.45	
Back EMF Constant(ph-ph)	V _{rms} /rad/s	0.7	4.7	1	2.1	1.7		2.8	4.5	1.9	1.7	
Pole Pair	-	8	12	10		10				10		
Max. Speed *	rps	10	3.6	10	8	5		4.5	8	9		
Resolution	ppr	655360~8192000	864000~10800000	518400~6480000		655360~8192000				327680~4096000		
Accuracy *	arcsec	±30	±30	±30		±30				±30		
Repeatability *	arcsec	±2	±2	±2.5		±2				±4		
Axial Run-out (no-load)	μm	20/10/5	30	20/10/5		20/10/5				20/10/5		
Radial Run-out (no-load)	μm	20/10/5	30	20/10/5		20/10/5				20/10/5		
Max. Axial Load	kgf	120	410	90		530				120		
Max. Moment Load	N·m	15	80	12		96				15		
Rotor Inertia	kgm ²	0.00226	0.0195	0.0007	0.0012	0.012	0.021	0.024	0.029	0.0031	0.0052	
Motor Weight	kg	4.4	11	3.9	5.4	6.4	9.8	12.2	15.6	13.9	22	
Applicable drive	200 V	MADL□ 15△△	MADL□ 05△△	MADL□05△△		MBDL□ 25△△	MCDL□35△△			MDDL□ 45△△	MEDL□ 83△△	
	100 V	MADL□ 11△△	MADL□ 01△△	MADL□01△△		MBDL□ 21△△	MCDL□31△△			MCDL□ 31△△	□	

PERFORMANCES	UNIT	JTR24 series			JTR30 series			JTR49 series			JTR66 series	
		JTR2403	JTR2408	JTR2413	JTR3015	JTR3030	JTR3045	JTR4960	JTR4990	JTR49C0	JTR6625	JTR6637
Continuous Torque	N·m	9.8	25.3	40.9	50	100	150	200	300	400	1350	2000
Peak Torque	N·m	29.3	75.3	121.8	145	280	420	540	780	1090	2500	3700
Continuous Current	A _{rms}	2.4	3.4	3.2	4.7	9		10.5			60.9	
Peak Current	A _{rms}	7.2	10.2	9.6	14.1	27		35.1			120.9	
Torque Constant	N·m/A _{rms}	4.1	7.4	12.8	10.6	11.1	16.7	19	28.6	38.1	22.2	32.8
Motor Constant	N·m/W ^{1/2}	1.3	2.5	3.5	3.8	6.3	8.1	10.8	14.5	17.7	21.5	30.2
Thermal Resistance	°C/W	1.52	0.89	0.69	0.53	0.37	0.27	0.27	0.22	0.18	0.024	0.021
Back EMF Constant(ph-ph)	V _{rms} /rad/s	2.4	4.3	7.4	6.1	6.4	9.6	11	16.5	22	12.8	19
Pole Pair	-	16			16			24			24	
Max. Speed *	rps	5	4.5	2.8	2.9	3	2	2.3	1.4	1	1	
Resolution	ppr	655360~8192000			864000~2160000			1036800~12960000			1036800~12960000	
Accuracy *	arcsec	±30			±30			±30			±30	
Repeatability *	arcsec	±2			±2			±2			±2	
Axial Run-out (no-load)	μm	20/10/5			30/15/5			40/20/10			50	
Radial Run-out (no-load)	μm	20/10/5			30/15/5			40/20/10			50	
Max. Axial Load	kgf	410			1100			1100			9000	
Max. Moment Load	N·m	80			250			250			8000	
Rotor Inertia	kgm ²	0.0092	0.0143	0.0203	0.1004	0.1288	0.1576	0.536	0.631	0.762	3.57	4.42
Motor Weight	kg	10.7	14.7	19.7	46.7	58.5	70.2	80.2	91.5	100.5	250	303
Applicable drive	200 V	MBDL□ 25△△	MCDL□35△△		MDDL□ 45△△	MEDL□83△△		MEDL□83△△			MHDL□E3△△	
	100 V	MBDL□ 21△△	MCDL□31△△		□		□			□		

1) Dependent on the encoder resolution. 2) Possible to get more high resolution.

Application Sample

- Alignment and indexing equipment
- Semiconductor test handler
- Glass titler
- Machine tools
- Loader / unloader
- Die bonder, LED handler

Sales area

- China
- Taiwan
- Korea
- United States of America
- Japan

Language

- Chinese
- Japanese
- English
- Korean

For more information

URL: <http://www.justek.com>

Contact: **Justek, Inc.**

630-46 Nambudae-ro, Jinwi-myeon, Pyeongtaek, Gyeonggi-do, Korea

Japan branch : Morikawa Koudenki, Inc.

Hellios Kannai Bldg., 3-21-2, Motohama-cho, Naka-ku, Yokohama-shi, Kanagawa-ken, 231-0004, Japan

[E-mail: info@justek.com]

TEL: +82-31-647-5500 FAX: +82-31-647-5555

[E-mail: sjkang@justek.com]

TEL: +81-45-222-0779 FAX: +81-45-222-8283

Tubular Linear Motor

Series P10-54

Features

- Controlled by standard third-party servo drives
- 230 VAC and 3x400 VAC Technology
- Forces up to 900 N
- Speed up to 11 m/s
- Stroke range up to 2'000 mm
- A/B incremental encoder 1 μ m
- Extremely high dynamics
- Rotating push-pull TWIN connector for power and encoder cables
- One-piece clamping flange



Specification

	PS10-54x120U	PS10-54x180U	PS10-54x240U	PS10-54x330U
Maximum stroke (mm)	2240	2180	2120	2060
Peak force (N)¹⁾	357	535	714	892
Continuous force (N)^{2)/3)}	70 / 102	105 / 153	140 / 204	175 / 255
Peak velocity (m/s)	8.5	11.1	8.4	8.7
Peak acceleration (m/s²)¹⁾	245	366	410	413
Force constant (N/Arms)	65	50	66	64
Nominal DC-Link voltage (Vdc)	560			
Applicable MINAS drive⁴⁾	A5BL / A6BL, 1- to 3-phase, 2DOF			

- 1) Real time calculation of motor winding temperature required (including temperature sensor monitoring)
 2) Motor with flange @ 25 °C ambient temperature
 3) Motor with flange and fan cooling @ 25 °C ambient temperature
 4) Rating (voltage and current) act on application requirements. Please contact us with application details to evaluate appropriate model.

Principle

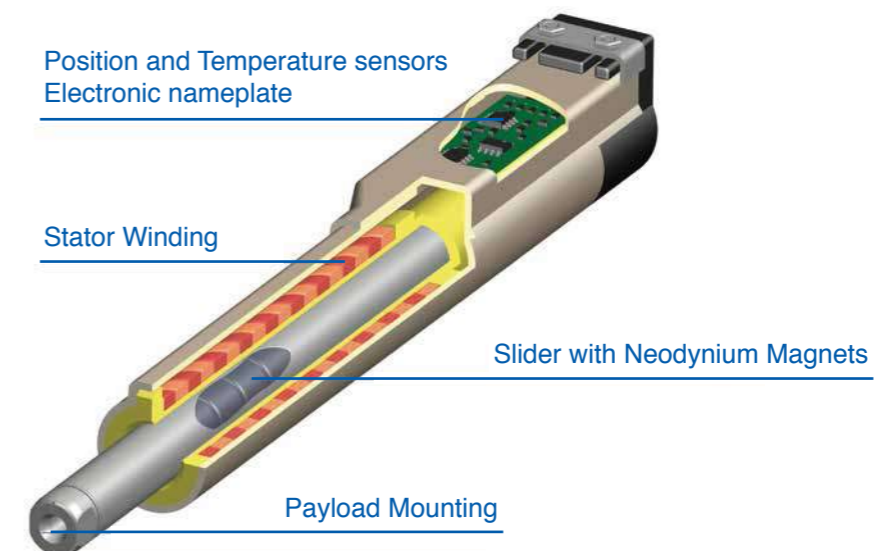

Sales area

- Germany
- United States of America
- Italy
- Rest of the world

Language

- German
- English
- Italian

Headquarter in Europe and USA. Worldwide representatives.

For more information

NTI AG URL: www.linmot.com
 LinMot USA, Inc. URL: www.linmot-usa.com/

Contact: NTI AG

Bodenaeckerstrasse 2 CH-8957 Spreitenbach Switzerland

LinMot USA, Inc.

204 E Morrissey Dr. Elkhorn, WI 53121 USA

[E-mail: office@linmot.com]

TEL: +41 (0)56 419 91 91 FAX: +41 (0)56 419 91 92

[E-mail: usasales@linmot.com]

TEL: 877 546 3270 FAX: 800 463 8708

Linear Shaft Motor

S series/L series

Features

- Coreless Technology
- Zero Cogging
- High Force and High Precision
- Energy Efficient
- Simple Design and Easy Integration

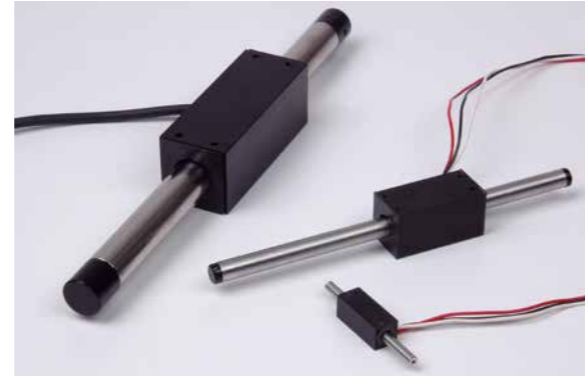

Specification

	Unit	S040 series			S080 series			S120 series			S160 series			S200 series		
		S040D	S040T	S040Q	S080D	S080T	S080Q	S120D	S120T	S120Q	S160D	S160T	S160Q	S200D	S200T	S200Q
Shaft Diameter	mm	4	4	4	8	8	8	12	12	12	16	16	16	20	20	20
Stroke Length Range	mm	20 ~ 40	20 ~ 40	20 ~ 40	~200	~200	~200	~1050	~1050	~1050	~1050	~1050	~1050	~1550	~1550	~1550
Continuous Force	N	0.29	0.45	0.58	1.8	2.7	3.5	4.5	6.6	8.9	10	15	20	18	28	38
Continuous Current	A	0.3	0.3	0.3	0.8	0.8	0.8	0.4	0.4	0.4	0.6	0.6	0.6	0.6	0.6	0.6
Peak Force	N	1.2	1.8	2.3	7.2	11	14	18	27	36	40	60	81	72	112	152
Peak Current	A	1.1	1.1	1.1	3.4	3.4	3.4	1.6	1.6	1.6	2.5	2.5	2.5	2.4	2.4	2.4
Gap	mm	0.5	0.5	0.5	0.5	0.5	0.5	0.5	0.5	0.5	0.5	0.5	0.5	0.75	0.75	0.75
Forcer Length	mm	25	34	43	40	55	70	64	88	112	80	110	140	94	130	166
MINAS A5L Model	200 V	-			MADHT1505L** ^{*1}			-			MADHT1505L**			-		
	100 V	-			MADHT1105L** ^{*1}			-			MADHT1105L**			-		
MINAS A6L Model	200 V	-			MADL□05△△ ^{*1}			-			MADL□05△△			-		
	100 V	-			MADL□01△△ ^{*1}			-			MADL□01△△			-		
MINAS A5ML Model	24 V	MMDHT2C09LA														

	Unit	S250 series			S320 series			S350 series			S427 series			S435 series		
		S250D	S250T	S250Q	S320D	S320T	S320Q	S350D	S350T	S350Q	S427D	S427T	S427Q	S435D	S435T	S435Q
Shaft Diameter	mm	25	25	25	32	32	32	35	35	35	42.7	42.7	42.7	43.5	43.5	43.5
Stroke Length Range	mm	~1550	~1550	~1550	~2000	~2000	~2000	~2000	~2000	~2000	~2000	~2000	~2000	~2000	~2000	~2000
Continuous Force	N	40	60	75	56	85	113	104	148	190	100	150	200	116	175	233
Continuous Current	A	1.3	1.3	1.3	1.2	1.2	1.2	1.5	1.5	2.7	3.0	3.0	3.0	3.0	3.0	3.0
Peak Force	N	160	240	300	226	338	451	416	592	760	400	600	800	464	700	932
Peak Current	A	5.1	5.1	5.1	5.0	5.0	5.0	6.0	6.0	10.8	12.0	12.0	12.0	12.0	12.0	12.0
Gap	mm	0.75	0.75	0.75	1.0	1.0	1.0	1.0	1.0	1.0	1.65	1.65	1.65	1.25	1.25	1.25
Forcer Length	mm	120	165	210	160	220	280	160	220	280	220	310	400	220	310	400
MINAS A5L Model	200 V	MBDHT2510L**			MBDHT2510L**			MBDHT2510L**			MCDHT3520L**			-		
	100 V	MBDHT2110L**			MBDHT2110L**			MBDHT2110L**			MCDHT3120L**			-		
MINAS A6L Model	200 V	MBDL□25△△			MBDL□25△△			MBDL□25△△			MCDL□35△△			-		
	100 V	MBDL□21△△			MBDL□21△△			MBDL□21△△			MCDL□31△△			-		

	Unit	S500 series			S605 series			L250 series			L320 series		
		S500D	S500T	S500Q	S605D	S605T	S605Q	L250D	L250T	L250Q	L320D	L320T	L320Q
Shaft Diameter	mm	50	50	50	60.5	60.5	60.5	25	25	25	32	32	32
Stroke Length Range	mm	~2000	~2000	~2000	~2000	~2000	~2000	~2000	~2000	~2000	~3000	~3000	~3000
Continuous Force	N	289	440	585	420	610	780	34	52	69	55	82	109
Continuous Current	A	3.8	5.8	7.7	8.8	8.6	8.4	1.3	1.3	1.3	1.3	1.3	1.3
Peak Force	N	1156	1760	2340	1700	2400	3100	138	207	276	218	327	436
Peak Current	A	15.2	23.3	30.8	35.0	34.0	34.0	5.2	5.2	5.2	5.0	5.0	5.0
Gap	mm	1.75	1.75	1.75	1.75	1.75	1.75	2.0	2.0	2.0	2.5	2.5	2.5
Forcer Length	mm	240	330	420	310	430	550	120	165	210	160	220	280
MINAS A5L Model	200 V	MDDHT5540L**		MEDHT7364L**	MEDHT7364L** ^{*1}			-			MBDHT2510L**		
	100 V	-		-	-			-			MBDHT2110L**		
MINAS A6L Model	200 V	MDDL□55△△		MEDL□83△△	MEDL□83△△ ^{*1}			-			MBDL□25△△		
	100 V	-		-	-			-			MBDL□21△△		

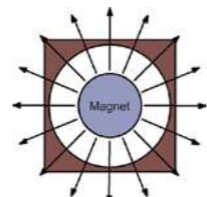

- As for ** mark in the model number, please refer to 00 page.
- As for □△ mark in the model number, please refer to 00 page.

*1 In case you drive around the motor maximum current value, please let us know so that we will select an appropriate driver.

Application Sample

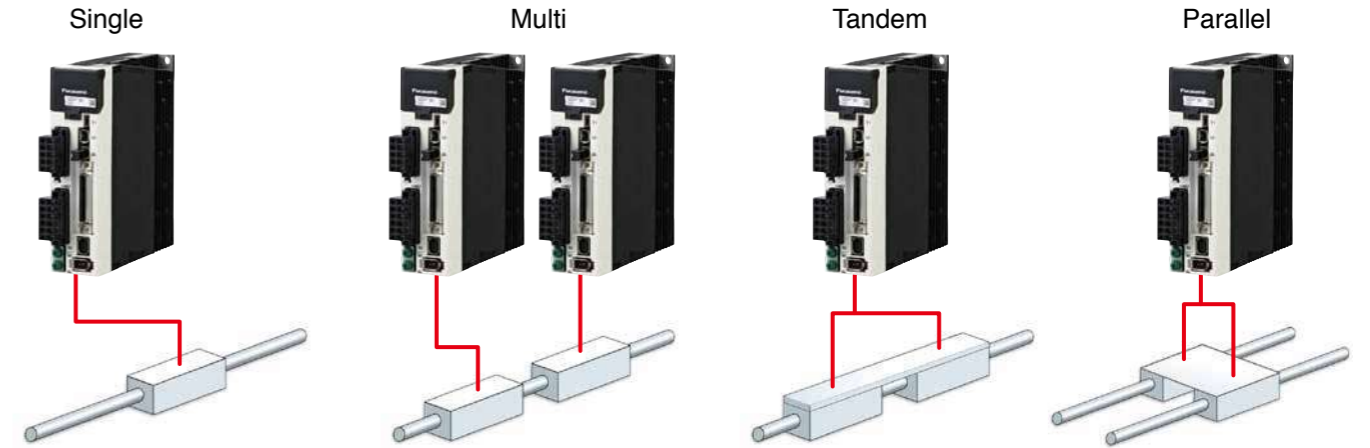

Construction

- Simple
- High Precision
- Non Contact

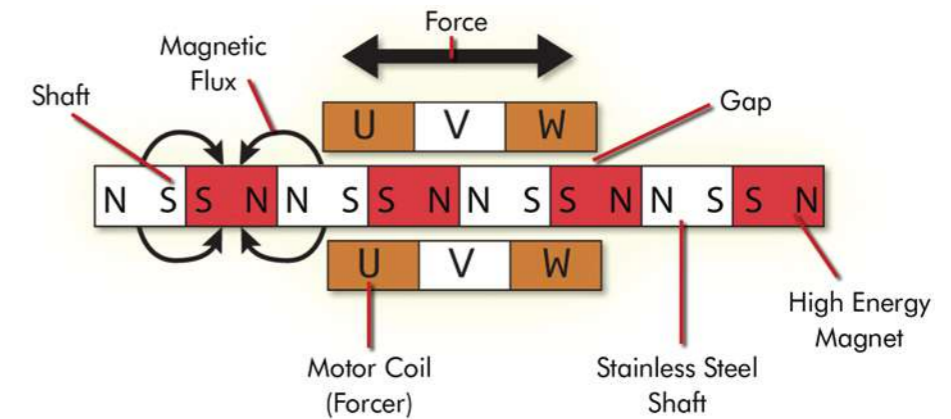

LINEAR MOTOR and DIRECT DRIVE MOTOR

Sales area

- Japan
- United States of America
- China
- Korea
- Taiwan
- Worldwide response

Language

- English
- Chinese
- Japanese

Please contact the following address for details.

For more information

URL: <https://nipponpulse.com/products/overview/linear-shaft-servomotors/>
 URL: <https://www.pulsemotor.com/global/>

Contact: **Nippon Pulse America., Inc.**

4 Corporate Drive, Radford, Virginia 24141 U.S.A.

[E-mail: info@nipponpulse.com]

TEL: +1-540-633-1677 / +1-540-633-1674

Linear Shaft Motor Stage

SLP series / SCR series

Features

SLP-series

- High Force
- High Speed



SCR-series

- High Precision
- Low Ripple at Low Speed
- High Repeatability



Specification

SLP series				
	Unit	SLP15	SLP25	SLP35
Resolution	μm	1 (HEIDENHAIN LIDA 279)	1 (HEIDENHAIN LIDA 279)	1 (HEIDENHAIN LIDA 279)
Stroke/Single Slider	mm	100 ~ 1300 (100 interval)	200 ~ 1200 (100 interval)	300 ~ 1200 (100 interval)
Stroke/Double Slider	mm	100 ~ 1200 (100 interval)	200 ~ 1000 (100 interval)	300 ~ 900 (100 interval)
Continuous Force	N	17	80	185
Continuous Current	A	0.51	1.2	2.7
Peak Force	N	90	340	970
Peak Current	A	2.7	5.1	14.4
Max. Velocity	m/s	3.0	3.0	3.0
Load Capacity (Horizontal)	Kg	5	30	60
MINAS A5L Model	200 V	MADHT1505L * *	MBDHT2510L * *	MDDHT3530L * *
	100 V	MADHT1105L * *	MBDHT2110L * *	—
MINAS A6L Model	200 V	MADL□05△△	MBDL□25△△	MDDL□45△△
	100 V	MADL□01△△	MBDL□21△△	—

SCR series					
	Unit	SCR50	SCR75	SCR100	SCR150
Motor part number		S040Q	S080Q	S080Q	S160D
Resolution	μm	1, 0.5, 0.1, 0.05, 0.01	1, 0.5, 0.1, 0.05, 0.01	1, 0.5, 0.1, 0.05, 0.01	1, 0.5, 0.1, 0.05, 0.01
Stroke	mm	20, 40	50, 100, 150	50~300 (50 interval)	100~300 (50 interval)
Continuous Force	N	0.58	3.5	3.5	10
Continuous Current	A	0.3	0.84	0.84	0.62
Peak Force	N	2.3	14	14	40
Peak Current	A	1.1	3.4	3.4	2.5
Max. Velocity	m/s	0.5 ~ 0.6 *2	1.1 ~ 1.5 *2	0.9 ~ 1.3 *2	1.3 ~ 1.5 *2
Load Capacity (Horizontal)	Kg	10	45.5	45.5	45.5
MINAS A5L Model	200 V	—	MADHT1505L * * *1	—	MADHT1505L * *
	100 V	—	MADHT1105L * * *1	—	MADHT1105L * *
MINAS A6L Model	200 V	—	MADL□05△△ *1	—	MADL□05△△
	100 V	—	MADL□01△△ *1	—	MADL□01△△
MINAS A5ML Model	24 V	—	MMDHT2C09LA	—	—

*1 In case you drive around the motor maximum current value, please let us know so that we will select an appropriate driver.

*2 The encoder resolution is 1 μm with no load condition.

• As for ** mark in the model number, please refer to 00 page.
• As for □△ mark in the model number, please refer to 00 page.

Application Sample

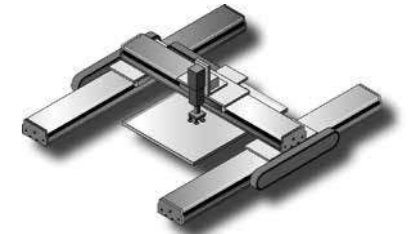
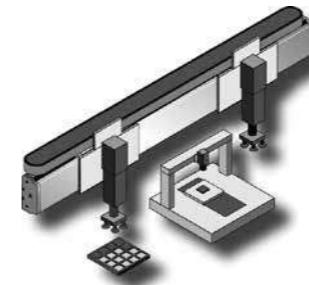

Customized SCR stage



Construction

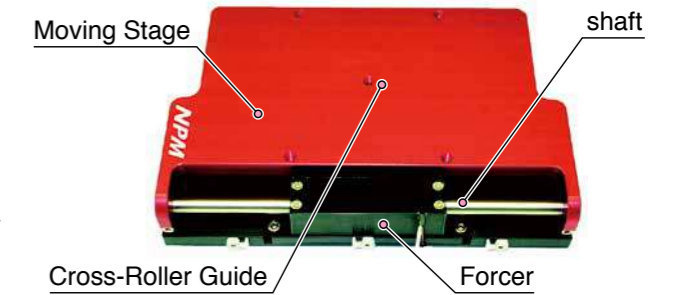
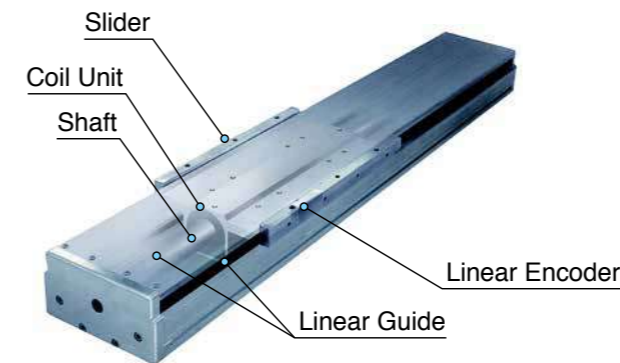

Sales area

- Japan
- United States of America
- China
- Korea
- Taiwan
- Worldwide response

Please contact the following address for details.

Language

- English
- Chinese
- Japanese

For more information

<SLP series>

URL: <https://www.nipponpulse.com/products/overview/slp-stage/>

<SCR series>

URL: <https://www.nipponpulse.com/products/overview/linear-shaft-stages>

Contact: **Nippon Pulse America, Inc.**

4 Corporate Drive, Radford, Virginia 24141 U.S.A.

[E-mail: info@nipponpulse.com]

TEL: +1-540-633-1677 / +1-540-633-1674

Core and Coreless Linear Motor

Core / Cased-Core / Coreless Type

Features

Core Type



- High Force
- Optimization Attraction Force

Cased-Core Type



- Low Heat
- Cogging Minimization

Coreless Type



- Zero Cogging
- Zero Attraction Force

Specification

Type	Model	Continuous Force [N]	Continuous Current [Arms]	Max Force [N]	Mover Weight [kg]	Magnet Pole Pitch [mm]	Stator Weight [kg/m]	PANASONIC AMP
Iron Core	SWL-PMI10~40C	18.8~75.2	1.3	56.4~225.7	0.2~0.8	18	1.7	MADL*15**
	SWL-PS10~40C	42.1~166.7	2.0	126.3~500.1	0.4~1.3	24	2.4	MBDL*25**
	SWL-PM10~40C	78.3~315.3	3.8	234.9~945.9	0.6~2.3	30	3.6	MCDL*35**
	SWL-PL10~40C	162.6~639.3	6.4	487.8~1917.9	2.5~7.9	42	6.9	MDDL*55**
	SWL-PE10~40C	401.8~1638	11.3	1205.4~4915	5.3~19	60	13.7	MEDL*83**
Cased-Iron Core	SWL-ePMI10~40C	20~80	1.5	55~205	0.2~0.7	18	1.7	MADL*15**
	SWL-ePS10~40C	55~215	2.3	150~580	0.5~1.6	30	2.6	MBDL*25**
	SWL-ePM10~40C	80~315	3.8	230~885	0.7~2.5	30	4	MCDL*35**
	SWL-ePL20~40C	360~700	6.7	1015~2000	4.7~9.1	60	7	MDDL*55**
	SWL-ePE20~40C	770~1500	10	2165~4300	8.2~16	60	15.8	MEDL*83**
Core less	SWL-DMI20~50	24.7~61.7	1.3	74.1~185.2	0.3~0.6	24	7.9	MADL*15**
	SWL-DS20~50	45.2~113.1	1.96	135.7~339.2	0.4~0.9	24	10.6	MBDL*25**
	SWL-DM20~50	83.3~208.3	3.65	250~624.9	0.6~1.4	30	11.2	MCDL*35**
	SWL-DL20~50	188.5~471.2	10.2	565.4~1413.6	1.3~3.1	42	18.6	MEDL*83**
	SWL-DE10~40	300.9~1203.8	13.9	902.8~3611.3	1.8~6.3	84	29.2	MFDL*A3**
	SWL-DU20~40	1100~2200	12.7~25.4	3300~6600	5.6~11	84	46.3	DU20 : MEDL*83** DU30/DU40 : MFDL*B3**

Application Sample

Linear Stage



Multi-Head Stage

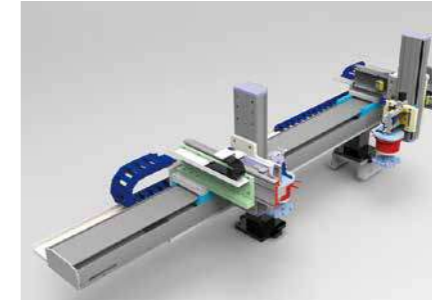

Gantry

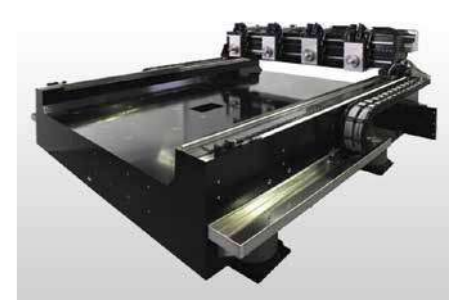

Selection Guide

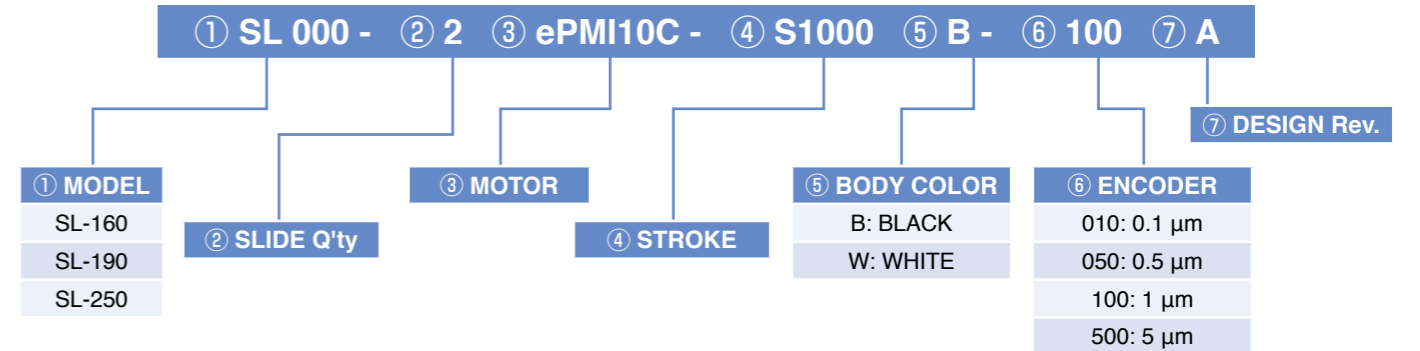

Model	MOTOR / Continuous Force			
SL-160	ePMI10C	20N	PMI10C	18N
	ePMI20C	40N	PMI20C	38N
	ePMI30C	60N	PMI30C	56N
	ePMI40C	80N	PMI40C	75N
	ePS10C	55N	PS10C	42N
	ePS20C	110N	PS20C	84N
	ePS30C	160N	PS30C	125N
SL-190	ePM10C	80N	PM10C	78N
	ePM20C	155N	PM20C	157N
	ePM30C	235N	PM30C	236N
	ePM40C	315N	PM40C	315N
SL-250	-	-	PL10C	162N
	ePL20C	360N	PL20C	319N
	ePL30C	530N	PL30C	480N
	ePL40C	700N	PL40C	639N

Sales area

- Korea
- Japan
- China
- Vietnam

Language

- Korean
- English

For more information

URL: <http://www.sewomotor.com>

Contact: **SEWOO INDUSTRIAL SYSTEMS CO., LTD**

17, Emtibeui 12-ro 22beon-gil, Danwon-gu, Ansan-si, Gyeonggi-do, Korea

[E-mail: sewomotor@daum.net]

TEL: +82-31-365-5400

Linear stages with integrated linear motors

MLE-, MLL- and MLU-Series

Features

- Compact and smart design
- Low carriage weight for high dynamic
- High force density
- High resolution encoder
- Long axis up to 10000 mm stroke
- Big range of sizes and options

Competent partner in electromechanical solutions

Standard Plug & Play linear units

Customized and flexible solutions



Specification

Ironcore MLE Series				
Performance Parameters		MLE3	MLE5	MLE7
Continuous Force (N)		55 - 315	200 - 800	400 - 1000
Peak Force (N)		105 - 630	400 - 1600	1600 - 4000
Nominal current (Arms)		1.5 - 6.0	2.26 - 9.0	4.1 - 8.5
Peak current (Arms)		3.1 - 12.4	5.0 - 20.0	10 - 20
Thermal Resistance (°C/W)		1.5 - 0.25	0.48 - 0.12	0.15 - 0.06
Coil Unit Mass (kg)		0.6 - 2.3	1.5 - 5.2	4.9 - 11.6
Weight of carriage with coil (kg)		2.2 - 6.2	4.5 - 14.0	10.5 - 21.5
Attraction Force (N)		300 - 1300	950 - 3400	3400 - 8300
Recommended Drivers (230 V)	A6L	MADL*15** to MCDL*35**	MBDL*25** to MFDL*A3**	MCDL*35** to MFDL*A3**
	A5L	MADHT1507L** to MDDHT3530L**	MBDHT2510L** to MFDHTA390L**	MCDHT3520L** to MFDHTA390L**
Recommended Drives (400 V)	A6L	MDDL*44** to MEDL*84**	MDDL*54** to MFDL*B4**	MDDL*64** to MHDL*E4**
	A5L	MDDHT2407L** to MEDHT4430L**	MDDHT2412L** to MFDHTA464L**	MDDHT3420L** to MGDHTB4A2L**

Notes: MLE linear motor stages with incr. encoder SIN/COS 40 µm or absolute encoder.

Ironless MLU Series					
Performance Parameters		MLU30100	MLU30200	MLU30300	MLU30400
Continuous Force (N)		29	58	87	116
Peak Force (N)		100	200	300	400
Thermal Resistance (°C/W)		1.8	0.9	0.6	0.45
Coil Unit Mass (kg)		0.084	0.162	0.240	0.318
Weight of carriage with coil (kg)		0.6	0.7	1.5	2.0
Recommended Drivers (230 V)	A6L	MADL*15**	MCDL*35**	MDDL*45**	MDDL*55**
	A5L	MADHT1507L**	MCDHT3520L**	MDDHT3530L**	MDDHT5540L**

Ironcore MCE3 Series		
Performance Parameters	MCE30100	
Nominal current (Arms)	1.5	
Peak current (Arms)	5.8	
Continuous Force (N)	29	
Peak Force (N)	99	
Thermal Resistance (°C/W)	7.89	
Coil Unit Mass (kg)	0.4	
Weight of carriage with coil (kg)	1	
Recommended Drivers (230 V)	A6L	MBDL*25**
	A5L	MBDHT2510L**

Sales area

- Germany
- Spain
- Russia
- EU

Language

- English
- German
- Spanish
- Russian

For more information

URL : <http://www.sinadrives.com/>

Contact: SINADRIVES

SINADRIVES Germany:
Unsöldstrasse 2 | 880538 München | Germany

SINADRIVES Spain:
Avinguda Mas Pins, 164 Nave 6
17457 Riudellots de la Selva - Girona | Spain

[E-mail: info@sinadrives.com]
TEL: +49 (0) 89 255 575 898 FAX: +49 (0) 89 255 575 899

[E-mail: info@sinadrives.com]
TEL: +34 972 442 452 FAX: +34 972 442 317

Servo actuator

DD Motor (ZMD series)

Features

Realizing outstanding high speed and precision performances thanks to its small and compact design

- **Outer rotor mechanism**

The outer diameter's compact design enables to drive directly the roller, making it suitable for indexing rotation

- **High-resistance bearings**

Simple and rigid structure for a higher load resistance

- **Hollow diameter $\phi 50\text{mm}$**

Wiring and piping can be easily stored in the hollow space of the motor, reducing the installation space.

- **Low price**

Model's size reduction leads to a more competitive price matching today's markets needs

- **Short lead time/ quick delivery**

The reduction of the components and a smarter stock arrangement critically reduce the production lead time



- **What is a Direct Drive Motor?**

A DD Motor can transmit the torque of the electric motor directly to the driving objects, without the use of any reductions such as belts, pulleys or reduction drives.

- High efficiency
- Low noise
- Outstanding precision
- High reliability
- Maintenance-free

Specification

Model		ZMD-1003	ZMD-1007	ZMD-1010
Maximum torque	N·m	30	65	100
Continuous torque	N·m	10	21	33
Maximum current	Arms	3.5	7.1	8.8
Rated current	Arms	1.2	2.4	2.9
Maximum rotation speed	s ⁻¹	5	4.5	4
Sensor resolution	ppr	1310720 ^{*1}		
Repeatability positioning precision	Second	±3		
Allowed axial load	N	3500 ^{*2}		
Allowed moment load	N·m	150 ^{*3}		
Axial rigidity	mm/N	2 × 10 ⁻⁶ ^{*4}		
Moment rigidity	rad/N·m	2 × 10 ⁻⁶		
Rotor inertia	kg·m ²	0.014	0.017	0.02
Axial run-out/side run-out accuracy	μm	70 ^{*5}		
Weight	kg	8.2	11.5	14.5
MINAS A5L Model		MBDHT2510L*	MBDHT2510L*	MCDHT3520L*
MINAS A6L Model		MBDL*25S*	MBDL*25S*	MCDL*35S*

- If using radial load, axial load and moment load at the same time, please contact us.
- This motor can be used with any type of servo driver. However, when using a servo-driver that differs from the one suggested, please be sure to use it below the rated current value.

*1 With the use of RD1416SPW (RD converter) *2 Horizontal installation *3 Horizontal installation *4 By using cross-roller bearings *5 As option, it is also possible to improve the accuracy of surface deflection. For further details, please contact us.

Application Sample

The installation of the DD Motor enables more efficient operations and it doesn't require any maintenance

Roller-drive application e.g.

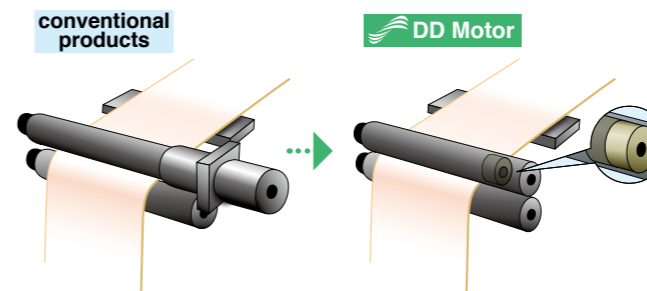

- Thanks to the outer motor, it's possible to build the motor inside the roller, saving space
- It works smoothly, avoiding uneven operations or movements

<Other possible applications>

- Printing equipment
- Coating machines
- Film-manufacturing machinery
- Roll-feeders

Indexing rotation application e.g.

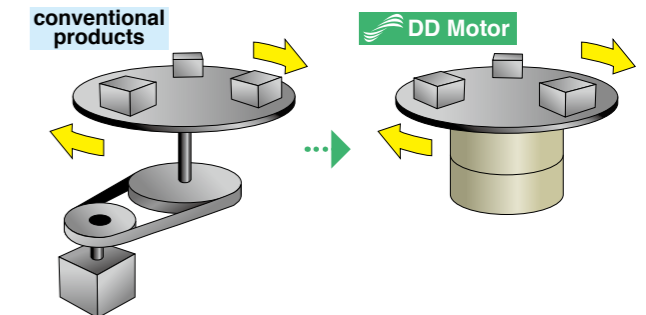

- Space-saving design for a more compact structure
- As no reduction device is needed, it's possible to avoid complex installations, improving its efficiency and reliability with no back-lash

<Other possible applications>

- Semiconductor making equipment
- Devices for manufacturing
- liquid crystal display panels
- Assembling robots
- All kind of indexing applications

Dimensional out drawing

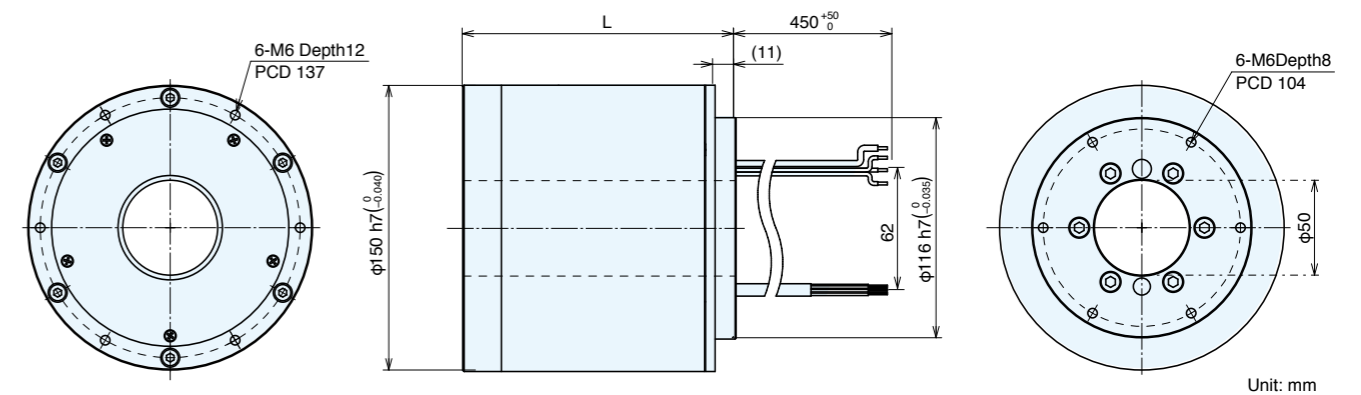

Model		ZMD-1003	ZMD-1007	ZMD-1010
External diameter of the motor	mm		Φ150	
Total length (L)	mm	113	143	173

Sales area

- Japan
- China
- United States of America
- Netherlands

Language

- Japanese
- English
- Chinese

Please contact the following address for details.

For more information

URL : <http://www.sinfo-t.jp/servo>

Contact: **SINFONIA TECHNOLOGY CO., LTD. Motion-Control Products Sales Dept.**

Shiba NBF Tower, 1-30, Shibadaimon 1-chome, Minato-ku, Tokyo, 105-8564, Japan

TEL: +81-3-5473-1827 FAX: +81-3-5473-1845

Coreless Linear Motor, Special Sodick V series

Features

In linear motors that will be assembled at the internal of machine tools, the generated heat must not influence the machine. Sodick linear motors have special cooling structure internal. And, In servo motors that will be assembled at the side of machine tools, the generated heat influence the machine a little.

Coreless Linear Motors

CA 144N-576N CAV3 220N-660N
CB SERIES 1200N-2133N
CG SERIES 3432N-4800N



Internal cooling structure * Patented in JAPAN, USA, CHINA

Special Motors

Sodick performs the design of a special motor according to a customer's demand.



← Circular Arc Motors

DD motor and the circular arc motor of ironcore and coreless motors are designed by Sodick.

Ultra Vacuum Linear Motors →

The linear motor corresponding to the vacuum of Sodick is equipped with the system which can be efficiently cooled also in a vacuum.



The configuration example of a linear motor system

Network Servo System by RTEX

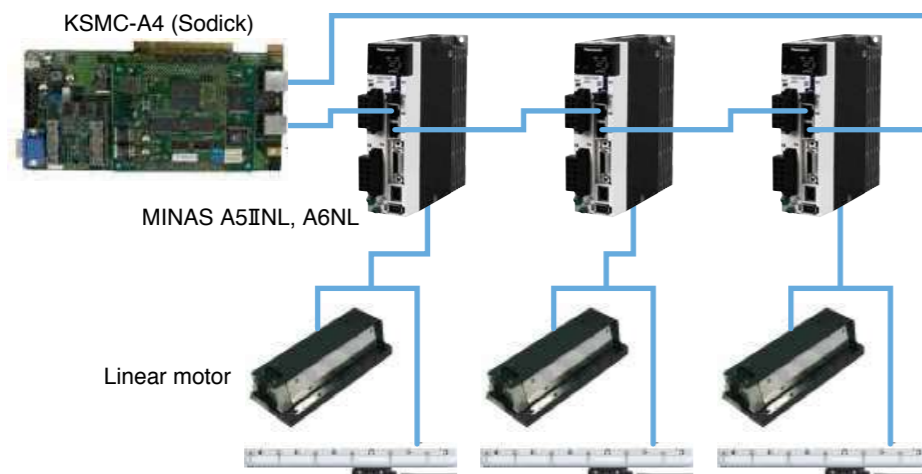

Pulse or Analog I/F by MINAS A5L, A6L

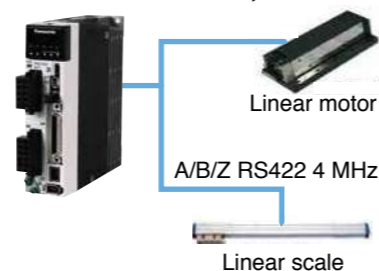

Specification

● Coreless Linear Motor CAV3 Series

Motor Type	Name □:Type	CA010v3B□				CA020v3B□				CA030v3B□			
		□=3 (High-response)		□=2 (High-speed)		□=3 (High-response)		□=2 (High-speed)		□=3 (High-response)		□=2 (High-speed)	
		without fin	with fin	without fin	with fin	without fin	with fin	without fin	with fin	without fin	with fin	without fin	with fin
Driver [12 kHz]		MCDL□35△△		MADL□15△△		MDDL□55△△		MCDL□35△△		MEDL□83△△		MDDL□45△△	
Cont. FORCE	N	32.5	43.5	32.5	43.5	64.9	86.9	64.9	86.9	97.4	130.4	97.4	130.4
Max. FORCE	N	220		220		440		440		660		660	
Rated SPEED	m/sec	6		3.3		6		3.3		6		3.3	
Max. SPEED	m/sec	7		6.1		7		6.1		7		6.1	
SIZE (D × W × L)	mm	35.5 × 66 × 100				35.5 × 66 × 196				35.5 × 66 × 292			
WEIGHT	kg	0.32				0.61				0.9			

● Coreless Linear Motor CA Series

Motor Type	Name Cooling	CA010(V)			CA020(V)			CA030(V)			CA040(V)		
		Oil	None	Water	Oil	None	Water	Oil	None	Water	Oil	None	Water
Driver [12 kHz]		MCDL□35△△			MDDL□55△△			MEDL□83△△			MEDL□83△△		
Cont. FORCE	N	48	16.8	60	96	36	120	134.4	55.2	168	176	72	220
Max. FORCE	N	144			288			432			576		
Rated SPEED	m/sec	7			7			7			7		
Max. SPEED	m/sec	7			7			7			7		
SIZE (D × W × L)	mm	30 × 110 × 130			30 × 110 × 202			30 × 110 × 274			30 × 110 × 346		
WEIGHT	kg	0.5	0.5	0.8	0.8	0.8	1.1	1.1	1.1	1.4	1.4	1.4	1.8

● Coreless Linear Motor CB Series

Motor Type	Name Cooling	CB100		CB110		CB160i		CB200i	
		None	Water	None	Water	None	Water	None	Water
Driver [6 kHz]		MDDL□55△△		MDDL□55△△		MEDL□83△△		MFDL□A3△△	
Cont. FORCE	N	135	350	139	406	188	536	251	744
Max. FORCE	N	1200		1392		1600		2133	
Rated SPEED	m/sec	2.5		1.8		2.7		2.7	
Max. SPEED	m/sec	4		3.6		3		3	
SIZE (D × W × L)	mm	50 × 165 × 303		50 × 165 × 303		50 × 165 × 303		50 × 165 × 375	
WEIGHT	kg	3.5		3.6		3.9		5.0	

● Coreless Linear Motor CG Series

Motor Type	Name Cooling	CG300		CG400	
		None	Water	None	Water
Driver [6 kHz]		MFDL□B3△△		MGDL□C3△△	
Cont. FORCE	N	520	1000	700	1300
Max. FORCE	N	3432		4800	
Rated SPEED	m/sec	1.5		1.5	
Max. SPEED	m/sec	2.4		2.4	
SIZE (D × W × L)	mm	62 × 240 × 478		62 × 240 × 595	
WEIGHT	kg	13.3		17.3	

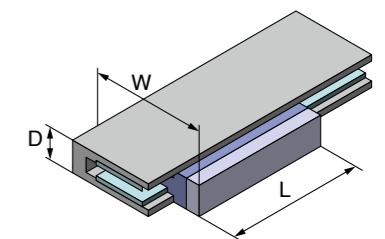

• Please refer to P.00 for driver specifications.

Sales area

• Japan • China

Please contact the following address for details.

Language

• English • Chinese • Japanese

For more information

URL : <http://www.sodick.jp/>

Contact: **Sodick Co., Ltd.**

3-12-1 Nakamachidai, Tsuzuki-ku, Yokohama-city, Kanagawa-Pref. 224-8522, Japan TEL: +81-45-948-1403 FAX: +81-45-941-5271

Ironcore Linear Motor, Special Sodick V series

Features

In linear motors that will be assembled at the internal of machine tools, the generated heat must not influence the machine. Sodick linear motors have special cooling structure internal. And, In servo motors that will be assembled at the side of machine tools, the generated heat influence the machine a little.

Ironcore Linear Motors

CM SERIES 190N-1172N

CE (M) 800N-1600N

CE (L) 1600N-6400N

CE (W) 4800N-7200N

CE (W2) 6400N-9600N



Special Motors

Sodick performs the design of a special motor according to a customer's demand.



← Circular Arc Motors

DD motor and the circular arc motor of ironcore and coreless motors are designed by Sodick.

Ultra Vacuum Linear Motors →

The linear motor corresponding to the vacuum of Sodick is equipped with the system which can be efficiently cooled also in a vacuum.



The configuration example of a linear motor system

Network Servo System by RTEX

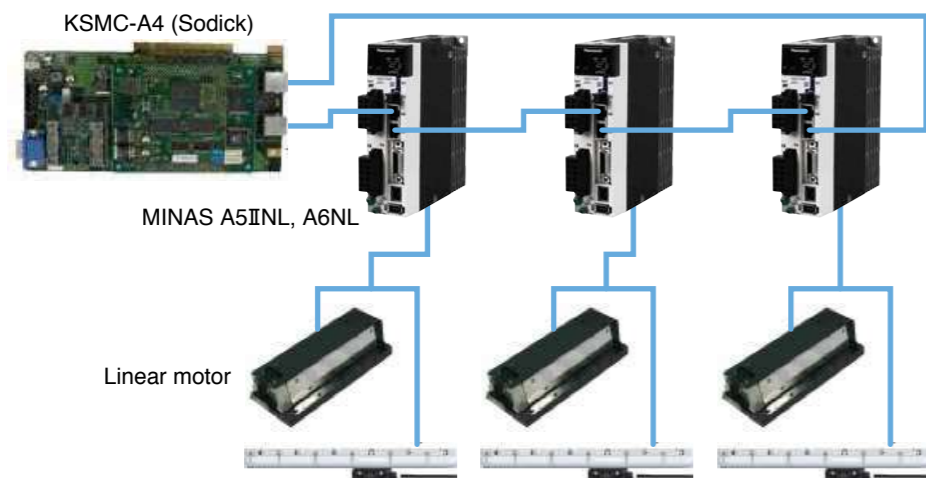

Pulse or Analog I/F by MINAS A5L, A6L

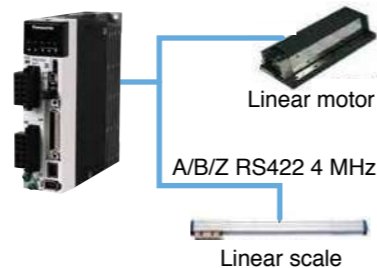

Specification

● Ironcore Linear Motor CM Series

Motor Type	Name	CM003(V)		CM007(V)		CM010(V)		CM020(V)	
		None	Fin	None	Fin	None	Fin	None	Fin
Driver [6 kHz]		MBDL□25△△		MDDL□45△△		MDDL□55△△		MEDL□83△△	
Cont. FORCE	N	28	41	58	86	89	132	178	264
Max. FORCE	N	190		390		600		1172	
Rated SPEED	m/sec	2.2		2.2		2.2		2.2	
Max. SPEED	m/sec	5		5		5		5	
SIZE (D × W × L)	mm	41 × 50 × 115		41 × 75 × 115		41 × 100 × 115		41 × 100 × 211	
WEIGHT	kg	0.9		1.3		1.7		3.4	

● Ironcore Linear Motor CE(M) Series

Motor Type	Name	CE033			CE066L		
		Oil	None	Water	Oil	None	Water
Driver [6 kHz]		MEDL□83△△			MFDL□B3△△		
Cont. FORCE	N	400	200	500	800	400	1000
Max. FORCE	N	800			1600		
Rated SPEED	m/sec	4			4		
Max. SPEED	m/sec	6			6		
SIZE (D × W × L)	mm	60 × 81 × 244 (75 × 125 × 247)			60 × 81 × 433 (75 × 125 × 436)		
WEIGHT	kg	7.5			13.8		

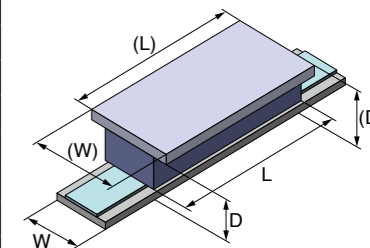

● Ironcore Linear Motor CE(L) Series

Motor Type	Name	CE066			CE133			CE200			CE266		
		Oil	None	Water	Oil	None	Water	Oil	None	Water	Oil	None	Water
Driver [6 kHz]		MEDL□83△△			MFDL□B3△△			MGDL□C3△△			MHDL□E3△△		
Cont. FORCE	N	870	390	900	1740	780	2000	2610	1170	3000	3480	1560	4000
Max. FORCE	N	1600			3200			4800			6400		
Rated SPEED	m/sec	2			2			2			2		
Max. SPEED	m/sec	3			3			3			3		
SIZE (D × W × L)	mm	63 × 150 × 244 (78 × 160 × 247)			63 × 150 × 465 (78 × 160 × 471)			63 × 150 × 641 (78 × 160 × 647)			63 × 150 × 854 (83 × 160 × 860)		
WEIGHT	kg	12			24			33			42		

• Please refer to P.00 for driver specifications.

Sales area

• Japan • China

Language

• English • Chinese • Japanese

Please contact the following address for details.

For more information

URL : <http://www.sodick.jp/>

Contact: **Sodick Co., Ltd.**

3-12-1 Nakamachidai, Tsuzuki-ku, Yokohama-city, Kanagawa-Pref. 224-8522, Japan TEL: +81-45-948-1403 FAX: +81-45-941-5271

Ironcore and ironless linear motors

T- and U-Series

Features

- High force density
More force in a smaller packing means lowering footprint
- Low thermal resistance
Allowing good heat transfer
- Ironcore linear motors:
Low cogging for smooth motion and position accuracy
Approved for CSA, CE, and RoHS
Optional watercooling for TL- and TBW-series
- Ironless linear motors:
High acceleration and dynamics
No cogging, extremely low force ripple
Approved for CE and RoHS
Also available as vacuum-rated motors



Specification

Ironcore T-Series				
Performance Parameters	TM	TL	TB	TBW
Continuous Force (N)	60 - 360	200 - 840	760 - 1900	1200 - 3000
Peak Force (N)	120 - 720	450 - 1800	1800 - 4500	2700 - 6750
Maximum Continuous Current (Arms)	1.5 - 9.3	2.26 - 18.1	4.1 - 20.5	6.5 - 32.3
Peak Current (Arms)	3.1 - 18.9	5.0 - 40.0	10.0 - 50.0	15.0 - 75.0
Thermal Resistance (°C/W)	1.5 - 0.38	0.48 - 0.12	0.15 - 0.06	0.10 - 0.04
Coil Unit Mass (kg)	0.6 - 2.3	1.5 - 5.2	4.9 - 11.6	7.3 - 18.2
Attraction Force (N)	300 - 1300	950 - 3400	3400 - 8300	4900 - 12450
MINAS A6L Series Recommended Drivers (1/3-phase 230 V ¹)	MADL*05** to MDDL*55**	MBDL*25** to MFDL*A3**	MCDL*35** to MFDL*B3**	MDDL*55** to MGDL*C3**
MINAS A6L Series Recommended Drivers (3-phase 400 V ¹)	MDDL*44** to MFDL*A4**	MDDL*54** to MGDL*C4**	MDDL*64** to MGDL*C4**	MEDL*84** to MHDL*E4**

*1 Please refer to the suitable driver part number at page of A6L according to supply voltage.

Ironless U-Series				
Performance Parameters	UM3	UM6	UM9	UM12
Continuous Force (N)	29	58	87	116
Peak Force (N)	100	200	300	400
Maximum Continuous Current (Arms)	0.8/1.5	1.6/2.9	2.4/4.4	3.2/5.8
Peak Current (Arms)	2.8/5.0	5.5/10.0	8.3/15.0	11.0/20.0
Thermal Resistance (°C/W)	1.8	0.9	0.6	0.45
Coil Unit Mass (kg)	0.084	0.162	0.240	0.318
MINAS A6L Series Recommended Drivers (1/3-phase 230 V)	MADL*05** to MBDL*25**	MBDL*25** to MCDL*35**	MCDL*35** to MDDL*45**	MCDL*35** to MDDL*55**

Sales area

- Netherland
- Germany
- Korea
- Rest of the world

Language

- English
- German
- Korean

Tecnotion has worldwide subsidiaries and representatives:

Please contact the following addresses for details

For more information

URL : <http://www.tecnotion.com/>

Contact: Tecnotion

International:

Tecnotion BV, Almelo/The Netherlands

[E-mail: sales@tecnotion.com]

TEL: +31 546536 300

For German-speaking countries (DACH):

Tecnotion GmbH, Munich/Germany

[E-mail: info@tecnotion.de]

TEL: +49 89 381537 400

For Korea:

Tecnotion Rep. of Korea, 883 Gwangyang 2-Dong

[E-mail: korea@tecnotion.com]

TEL: +82 10 7164 2525

Core and Coreless Linear Motor

F Series, G Series

Features

Core Type



- Rigid Structure
- Low cogging
- High-density Force
- Low thermal resistance
- Approved for CE

Coreless Type



- No cogging, low force ripple
- High-density Force
- Low thermal resistance
- Approved for CE

MOVER Specification

Item	Model	Dimension (L) × (W) × (H) [mm]	Force [N]		Current [Arms]		Force Constant [N/Arms]	Back EMF [V/(m/s)]	Motor Constant [N/sqrt(W)]	Resistance [Ohm]	Inductance [mH]	Power [W]	Magnetic Attraction [N]	Weight [kg]	Pole-Pitch [mm]	MINAS A6L Model
			Continu.	Max.	Continu.	Max.										
Core Type	FMIC40A 50S	44 × 38 × 16.4	8	25	1.3	3.9	6.4	5.5	4.8	2.4	2.0	2.9	42	0.2	18	MADL□15△△
	FMIC40A 80S	80 × 38 × 16.4	16	50			12.8	11.1	6.9	4.8	4.0	5.8	84	0.4		
	FMIC40A 120S	116 × 38 × 16.4	24	75			19.2	16.7	9.7	7.2	6.0	8.7	125	0.6		
	FMIC40A 150S	152 × 38 × 16.4	32	100			25.6	22.2	13.8	9.6	8.0	11.6	167	0.8		
	FMI40A 50S	44 × 42 × 25	20	61	1.3	3.9	15.7	7.9	7.8	5.4	10.7	6.9	102	0.2	18	MADL□15△△
	FMI40A 80S	80 × 42 × 25	40	122			31.3	15.9	11.0	10.8	21.4	13.7	204	0.5		
	FMI40A 120S	116 × 42 × 25	61	183			47.0	23.9	13.5	16.3	32.0	20.7	306	0.7		
	FMI40A 150S	152 × 42 × 25	81	244			62.7	31.8	15.6	21.7	42.8	27.5	407	0.9		
	FSM60A 60S	60 × 54 × 25	41	124	2.0	6.0	20.8	10.8	11.3	4.5	12.6	13.4	208	0.4	24	MBDL□25△△
	FSM60A 110S	108 × 54 × 25	83	249			41.5	21.5	16.0	9.0	25.2	26.9	415	0.8		
	FSM60A 160S	156 × 54 × 25	124	373			62.3	32.3	19.6	13.4	37.8	40.3	623	1.1		
	FSM60A 200S	204 × 54 × 25	166	498			83.1	43.0	22.7	17.9	50.4	53.8	831	1.4		
	FMD110A 70S	71 × 70 × 27	61	184	3.8	11.4	16.1	8.4	13.7	1.8	7.9	19.9	307	0.8	30	MCDL□35△△
	FMD110A 130S	131 × 70 × 27	122	368			32.3	16.7	19.4	3.7	15.8	39.9	613	1.4		
	FMD110A 190S	191 × 70 × 27	184	552			48.4	25.0	23.8	5.5	23.7	59.8	920	1.9		
	FMD110A 250S	251 × 70 × 27	245	736			64.6	33.4	27.5	7.4	31.6	79.7	1227	2.5		
	FMD110A 310S	311 × 70 × 27	306	920	80.7	41.8	30.8	9.2	39.5	99.6	1533	3.0				
	FLA190A 110S	108 × 100 × 41	158	476	6.4	19.2	24.8	19.7	22.5	1.6	13.4	50.0	794	2.1	48	MDDL□55△△
	FLA190A 200S	204 × 100 × 41	317	952			49.6	39.5	31.8	3.3	26.8	100.0	1588	4.2		
	FLA190A 300S	300 × 100 × 41	476	1429			74.5	59.2	38.9	4.9	40.2	150.0	2332	6.3		
	FLA190A 400S	396 × 100 × 41	635	1905			99.3	80.0	44.9	6.5	53.6	200.0	3177	8.4		
	FLB230A 110S	108 × 130 × 41	213	639	7.8	23.4	27.3	14.2	27.4	1.3	11.4	60.4	1065	3.1	48	MDDL□55△△
	FLB230A 200S	204 × 130 × 41	426	1278			54.6	28.4	38.8	2.6	22.8	120.7	2130	6.2		
	FLB230A 300S	300 × 130 × 41	639	1917			81.9	42.6	47.5	4.0	34.2	181.1	3195	9.3		
FLB230A 400S	396 × 130 × 41	852	2556	109.2			56.8	54.8	5.3	45.6	241.4	4260	12.4			
FEX450A 150S	146 × 160 × 47	405	1216	15.0	45.0	27.0	17.1	36.3	0.7	11.2	124.9	2027	5.5	66	MEDL□93△△	
FEX450A 280S	278 × 160 × 47	810	2432			54.0	35.8	51.3	1.5	22.5	249.8	4053	10.6			
FEX450A 410S	410 × 160 × 47	1216	3648			81.1	53.7	62.8	2.2	33.7	374.6	6080	15.9			
FEX450A 540S	542 × 160 × 47	1621	4864			108.1	71.6	72.5	3.0	44.9	499.5	8107	21.9			
Coreless Type	GMD110A 140S	140 × 37 × 88	91	274	3.8	11.4	24.0	11.2	11.2	5.5	8.4	66.1	0	0.8	30	MCDL□35△△
	GMD110A 200S	200 × 37 × 88	137	411			36.1	16.8	13.8	8.2	12.5	99.1	0	1.2		
	GMD110A 260S	260 × 37 × 88	182	548			48.1	22.4	15.9	10.9	16.7	132.2	0	1.7		
	GMD110A 320S	320 × 37 × 88	228	685			60.1	28.1	17.8	13.7	20.9	165.2	0	2.1		
	GLA190A 220S	223 × 44 × 141	294	882	6.4	19.2	45.9	23.5	21.8	5.3	22.7	181.9	0	2.4	48	MDDL□55△△
	GLA190A 320S	319 × 44 × 141	441	1323			68.9	35.3	26.7	8.0	34.0	272.9	0	3.3		
	GLA190A 420S	415 × 44 × 141	588	1764			91.9	47.0	30.8	10.6	45.4	363.9	0	4.3		
	GLA190A 510S	511 × 44 × 141	735	2205			114.8	58.7	34.5	13.3	56.7	454.8	0	5.3		

Application Sample



Single-Axis Stage

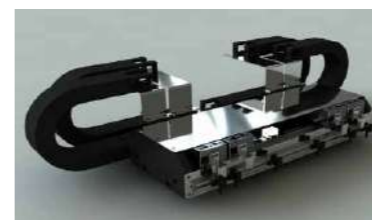

Multi-Mover Stage



Linear Desk-Top



Gantry Stage

Selection Guide

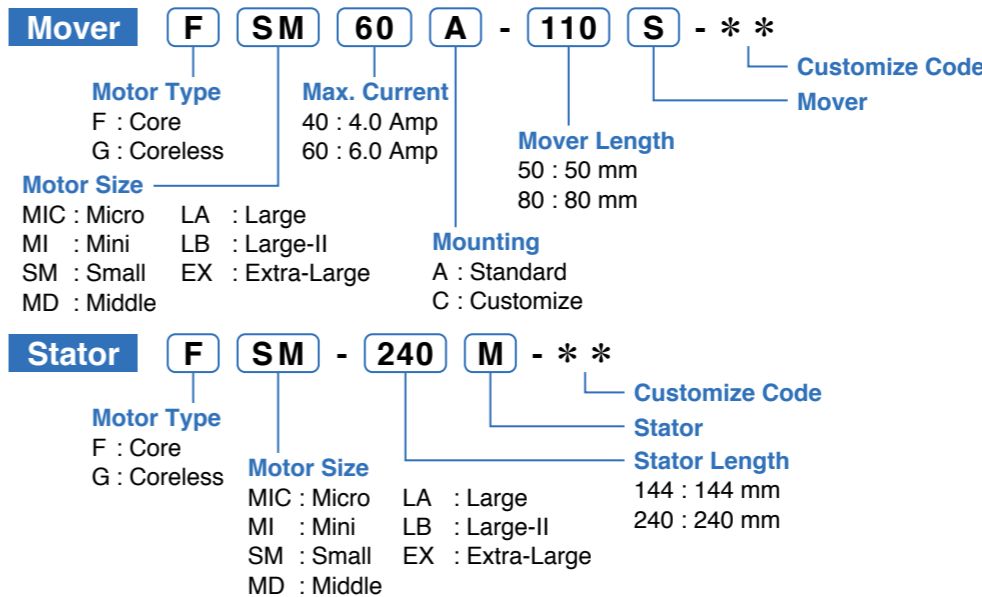

STATOR Specification

Item	Model	Length (mm)	
Core Type	FMIC-72M	72	
	FMIC-99M	99	
	FMIC-144M	144	
	FMIC-216M	216	
	FMIC-288M	288	
	FMI-144M	144	
	FMI-252M	252	
	FMI-324M	324	
	Core Type	FSM-144M	144
		FSM-240M	240
FSM-336M		336	
FMD-180M		180	
FMD-240M		240	
FMD-360M		360	
FLA-192M		192	
FLA-288M		288	
FLA-384M		384	
Core Type		FLB-192M	192
	FLB-288M	288	
	FLB-384M	384	
	FEX-264M	264	
	FEX-396M	396	
	FEX-528M	528	
Coreless Type	GMD-180M	180	
	GMD-240M	240	
	GMD-360M	360	
	GLA-192M	192	
	GLA-288M	288	
	GLA-384M	384	

Sales area

- United States of America
- China
- Vietnam

Language

- Korean : +82-1588-5982
- English : +82-2-2691-8888
- Chinese : +86-21-6727-7733
- Vietnamese : +84-9-0123-6795

Please contact the following address for details.

For more information

URL Korean : <http://www.tpcpage.co.kr/> English : <http://www.tpcpage.com/>
Chinese : <http://www.tpcpage.cn/>

Contact: **TPC Mechatronics Co., Ltd.**
39, Gammun 2-ro, Seo-gu, Incheon, Korea

[E-mail: aj1361@tanhay.com]
TEL: +82-32-580-0018

Enclosed Linear Encoders

S3 / G3 Series

Features

- The most robust optical encoder
- 3STATECH Technology
- Connectivity to MINAS series
- Vibration resistance of 30 G
- Longest absolute solution
- Angular Resolution up to 10 nm

Absolute glass

S3BP - G3BP SERIES
(MINAS A5 & MINAS A6)



3Statech

Absolute steel tape

LAP SERIES
(MINAS A5 & MINAS A6)



Specification

Item	Description		
Encoder model	G3BP	S3BP	LAP
Measuring standard	Optical absolute		
Interface	Panasonic communication protocol		
Scale material	Glass		Steel tape
Coef. expansion	≈ 8 μm/m°C		
Resolution	0.05 μm & 0.01 μm		
Max. Length	3040 mm	1240 mm	60 m
Accuracy	± 5 μm/m & ± 3 μm/m		
Max. Travel speed	3 m/s		
Vibration / Shock	30 G / 30 G	10 G / 30 G	10 G / 30 G
Operating temperature	0 °C to 50 °C		
Protection	IP53 (standard) / IP64 (with air purge)		
Power supply	DC 5 V ±10 %, 250 mA		
Max. Cable Length	30 m		

Angular Encoders

S2 / H2 Series

Features

- The most robust optical encoder
- 3STATECH Technology
- Connectivity to MINAS series
- Great accuracy at high speeds
- Angular Resolution up to 29 bits

Absolute glass

S2 – H2 SERIES
(MINAS A5 & MINAS A6)



Specification

Item	Description			
	H2A-D200i100	H2A-D200i60	H2A-D90	S2A-D90
Encoder Model	H2A-D200i100	H2A-D200i60	H2A-D90	S2A-D90
Measuring standard	Optical absolute			
Shaft diameter (ext/int)	Hollow 200/100	Hollow 200/60	Hollow 90/20	Solid 90
Interface	Panasonic communication protocol			
Scale material	Glass			
Resolution	29 bits (536870912 positions)		26 bits (67108864 positions)	
Max. RPM	750 RPM		1500 RPM	
Accuracy	± 1" , ± 2"		± 2.5" , ± 5"	
Vibration / Shock	10 G / 100 G			
Operating Temperature	-20 °C to 70 °C (± 5") / 0 °C to 50 °C (± 2")			
Protection	IP64			
Power supply	DC 5 V (3.6 V to 5,25 V)			
Max. Cable length	30 m			

Sales area

- Japan
- China
- Taiwan
- Worldwide response

Language

- Japanese
- Chinese
- English
- Spanish

For more information

URL: <https://www.fagorautomation.com/en/>

Contact: **Fagor Automation, S. Coop.**

Bo San Andrés No19 E-20500 – Arrasate/Mondragón, Spain

[E-mail: Jmviniegra@fagorautomation.es]

TEL: +34-943-719200 FAX: +34-943-791712

Exposed Linear Encoders

L2 Series

Features

- The most robust optical encoder
- Connectivity to MINAS series
- All mechanical type solutions
- Longest absolute solution

Absolute type

Incremental type

EXA, EXG & EXT SERIES
(MINAS A5, MINAS A6)

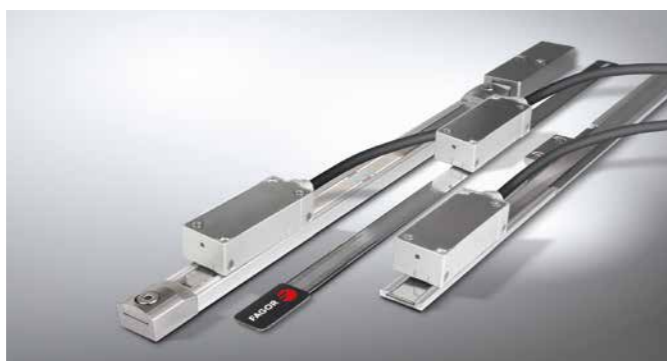

Specification

• Absolute type

Item	Description		
Encoder Model	EXA	EXG	EXT
Measuring standard	Optical absolute		
Installation	Adhesive	Guided	Tensioned
Interface	Panasonic communication protocol		
Scale material	Steel tape		
Coef. expansion	≈ 11 μm/m °C		
Resolution	0.05 μm & 0.01 μm		
Max. Length	9040 mm	4240 mm	30 m
Accuracy	± 10 μm/m	± 10 μm/m	± 5 μm/m
Max. Travel speed	8 m/s		
Vibration / Shock	20 G / 100 G		
Operating Temperature	0 °C to 50 °C		
Protection	IP40		
Power supply	DC 5 V ±10 %, 250 mA		
Max. Cable length	30 m		

Specification

• Incremental type

Item	Description		
Encoder Model	EXA	EXG	EXT
Measuring standard	Optical absolute		
Installation	Adhesive	Guided	Tensioned
Interface	TTL signals		
Scale material	Steel tape		
Coef. expansion	≈ 11 μm/m °C		
Resolution	Up to 0.1 μm		
Max. Length	16020 mm	6040 mm	30 m
Accuracy	± 10 μm/m	± 10 μm/m	± 5 μm/m
Max. Travel speed	Up to 4 m/s		
Vibration / Shock	20 G / 100 G		
Operating Temperature	0 °C to 50 °C		
Protection	IP40		
Power supply	DC 5 V ±10 %, 250 mA		

Sales area

- Japan
- China
- Taiwan
- Worldwide response

Language

- Japanese
- Chinese
- English
- Spanish

For more information

URL: <https://www.fagorautomation.com/en/>

Contact: **Fagor Automation, S. Coop.**

Bo San Andrés No19 E-20500 – Arrasate/Mondragón, Spain

[E-mail: Jmviniegra@fagorautomation.es]

TEL: +34-943-719200 FAX: +34-943-791712

Absolute Exposed Linear Encoder

LIC 2100 Series

Features

- Absolute linear encoder for measuring lengths up to 6 m
- Compact and light scanning head (scanning head weight 20 g without connecting cable)
- High traversing speed and high resolution (10 m/sec, 50 nm)
- Robust to contamination and wide mounting tolerances (nominal gap ± 0.5 mm: LIC 2199P)



LIC 2197P:
Steel scale tape is drawn into aluminum extrusions and fixed at center



LIC 2199P:
Steel scale tape cemented on mounting surface

Specification

	LIC 2197P	LIC 2199P
Measuring standard	Steel scale tape with absolute track	
Coefficient of linear expansion	≈ 10 ppm/K	
Accuracy grade	± 15 μm	
Resolution	100 nm or 50 nm	
Measuring Length ML (mm)	120 320 520 770 1020 1220 1520 2020 2420 3020 Larger measuring lengths up to 6020 mm available on request	
Interface	Panasonic serial interface (Pana01)	
Voltage supply	DC 3.6 V ~ 14 V	
Operating temperature	-10 °C ~ 70 °C	
Protection degree IEC60529	IP67 Only for scanning head	
Mounting method	Steel scale tape is drawn into aluminum extrusions and fixed at center	Steel scale tape cemented on mounting surface

Absolute Exposed Linear Encoder

LIC 4100 Series

Features

- Absolute linear encoder for measuring lengths up to 28 m (in case of LIC 4195P)
- Compact and light scanning head (scanning head weight 20 g without connecting cable)
- High traversing speed and high resolution (10 m/sec; 1 nm)
- Very small interpolation error
- Contains two tracks: absolute and incremental
- Robust to contamination and wide mounting tolerances (nominal gap ± 0.25 mm: LIC 4199P)
- Glass scale with low thermal expansion co-efficiency available.



LIC 4195P:
steel scale tape is drawn into the aluminum extrusions and tensioned



LIC 4197P:
steel scale tape is drawn into the aluminum extrusions and fixed at center



LIC 4193P/4199P:
Steel scale tape cemented on mounting surface

Specification

	LIC 4193P	LIC 4195P	LIC 4197P	LIC 4199P
Measuring standard	Glass or Glass ceramic	Steel tepe	Steel tepe	Steel tape
Coefficient of linear expansion	≈ 8 ppm/K ≈ 0 ppm/k	Depends on the mounting surface	≈ 10 ppm/K	≈ 10 ppm/K
Accuracy grade (depends on ML)	± 1 μm/± 3 μm/ ± 5 μm	± 5 μm	± 3 μm/ ± 5 μm/ ± 15 μm	± 3 μm/ ± 15 μm
Resolution	1 nm, 5 nm, 10 nm			
Measuring Length ML (mm)	240 ~ 3040	140 ~ 28840	240 ~ 6040	70 ~ 1020
Interface	Panasonic serial interface (Pana01)			
Voltage supply	DC 3.6 V ~ 14 V			
Operating temperature	-10 °C ~ 70 °C			
Protection degree IEC60529	IP67 Only for scanning head			
Mounting method	cemented on mounting surface	Aluminum extrusion and tensioned	Aluminum extrusion and fixed at center	cemented on mounting surface

Sales area

- Japan
- United States of America
- Germany
- China
- All over the world

Language

- English
- German
- Japanese
- Chinese

For more information

URL : <http://www.heidenhain.de>

Contact: **DR. JOHANNES HEIDENHAIN GmbH**
Dr.-Johannes-Heidenhain-Straße 5 83301 Traunreut, Germany

[E-mail: info@heidenhain.de]
TEL: +49 8669 31-0 FAX: +49 8669 5061

Absolute Angle Encoder with Integral Bearing RCN series / without Integral Bearing ECA 4490 series

Features - RCN series

- Absolute angle encoder with high accuracy
- Large hollow shaft up to $\Phi 100$ mm
- Integrated stator coupling
- Panasonic Serial Interface (Pana01)



RCN 8x90P

Specification - RCN series

	RCN 2590P	RCN 2390P	RCN 5590P	RCN 5390P	RCN 8590P	RCN 8390P
Measuring standard	DIADUR circular scale with absolute and incremental track					
Accuracy grade	$\pm 2.5''$	$\pm 5''$	$\pm 2.5''$	$\pm 5''$	$\pm 1''$	$\pm 2''$
Position error per signal period	$\leq \pm 0.4''$	$\leq \pm 0.4''$	$\leq \pm 0.4''$	$\leq \pm 0.4''$	$\leq \pm 0.2''$	
Position values/Revolution	28 bits	26 bits	28 bits	26 bits	29 bits	
Hollow shaft (mm)	$\phi 20$		$\phi 35$		$\phi 60$ or $\phi 100$	
Mechanical permissible speed	$\leq 1500 \text{ min}^{-1}$				$\leq 500 \text{ min}^{-1}$	
Protection degree IEC60529	IP64					

Features - ECA 4490 series

- Large hollow shaft absolute angle encoder with high accuracy
- Steel scale drum with three-point centering
- Panasonic Serial Interface (Pana01)



ECA 4490P

Specification - ECA 4490 series

		ECA 4490P									
Measuring standard CTE		Steel drum with absolute and incremental track $\approx 10.5 \text{ ppm/K}$									
Accuracy grade		$\pm 1.5'' \sim \pm 3.0''$ depends on drum size									
Resolution		27 bits \sim 29 bits depends on drum size									
Drum size in mm	inside diameter	70	80	120	150	185	180	210	270	425	512
	outside diameter	104.6	127.6	178.6	208.9	208.9	254.9	254.9	331.3	484.1	560.5
Protection degree IEC60529		IP67 only for scanning head									

Absolute Linear Encoder with Scale Housing LC series

Features

- Optical absolute linear encoder up to 4.2 m
- High vibration resistance
- High traversing speed with high resolution (3 m/sec, 1 nm / 10 nm)
- High reliability through double sealing lips (LC 195P)



LC 195P



LC 495P

Specification

	LC 195P	LC 495P
Measuring standard CTE	DIADUR glass scale with absolute and incremental track $\approx 8 \text{ ppm/K}$	
Accuracy grade	$\pm 3 \mu\text{m}$ (up to 3040 mm) or $\pm 5 \mu\text{m}$	
Resolution	$\pm 3 \mu\text{m} : 1 \text{ nm}$ $\pm 5 \mu\text{m} : 10 \text{ nm}$	
Measuring Length ML (mm)	140 mm \sim 4240 mm	70 mm \sim 2040 mm
Interface	Panasonic serial interface (Pana01)	
Voltage supply	DC 3.6 V \sim 14 V	
Operating temperature	0 °C \sim 50 °C	
Protection degree IEC60529	IP53 or IP64 (with compressed air)	

Sales area

- Japan
- United States of America
- Germany
- China
- All over the world

Language

- English
- German
- Japanese
- Chinese

For more information

URL : <http://www.heidenhain.de>

Contact: **DR. JOHANNES HEIDENHAIN GmbH**
Dr.-Johannes-Heidenhain-Straße 5 83301 Traunreut, Germany

[E-mail: info@heidenhain.de]
TEL: +49 8669 31-0 FAX: +49 8669 5061

Feedback Scale

SL700 series

Features

- High speed response with serial interface for MINAS series
- High speed response (10 m/s) and high resolution (0.1 μm)
- Magnetic digital scale technology produces real-time measurement data
- Magnetic detection system with excellent resistance to dust, oil and water (Maintenance free, IP67 grade model available)
- Wide variety of measurement length available from 50 mm to 100000 mm

Separate type / Magnetic detection system
Incremental scale
Digiruler

SL700 + PL101RP/RHP
SL710 + PL101RP/RHP
SL720 + PL101RP/RHP (Special model)
(A4NL, A5, A6 family)

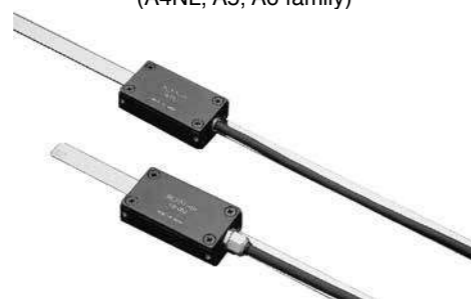

- Please contact Panasonic for the combination of A6 series driver and feedback scale.

Specification

Item	Description					
Type	Separate type / Magnetic detection system / Incremental scale Digiruler					
Part No.	SL700 + PL101RP	SL710 + PL101RP	SL720* + PL101RP	SL700 + PL101RHP	SL710 + PL101RHP	SL720* + PL101RHP
Compatible servo drive	A4NL / A5 / A6 family					
Effective length	50 mm to 100000 mm					
Accuracy	±10L μm (Integral number in unit of 1m when effective length is 3 m or less) When longer than 3 m, please contact sales					
Resolution	0.1 μm					
Signal type	Incremental					
Response speed	10 m/s					
Output signal	Dedicated to MINAS series, Serial output					
Origin signal	-	1 point	Multi point	-	1 point	Multi point
Protective design grade	IP50 or equivalent			IP67 or equivalent		

Provide high speed, high response, high reliability are secured through serial communication
CK-T185 conversion cable is required when connecting to A5, A6 family

* SL720 + PL101RP/RHP is special specification model. Please contact sales.

Feedback Scale

SR70/SR80 series

Features

- Magnetic detection system with excellent resistance to dust, oil and water
- Magnetic absolute scales (SR77/SR87) up to 10 nm resolution with 200 m/min response speed
- Slim type allows installation in narrow space (SR77/SR75)
- High rigidity provide resistance to shock and vibration (SR87/85 series)

Slim type / Magnetic
detection system
Absolute scale

SR77 series
(A4, A4N, A4NL, A5, A6 family)



Slim type / Magnetic
detection system
Incremental scale

SR75 series
(A4NL, A5, A6 family)



Robust type / Magnetic
detection system
Absolute scale

SR87 series
(A4, A4N, A4NL, A5, A6 family)



Robust type / Magnetic
detection system
Incremental scale

SR85 series
(A4NL, A5, A6 family)



- Please contact Panasonic for the combination of A6 series driver and feedback scale.

Specification

Item	Description			
Type	Slim type Magnetic detection system Absolute scale	Slim type Magnetic detection system Incremental scale	Robust type Magnetic detection system Absolute scale	Robust type Magnetic detection system Incremental scale
Part No.	SR77	SR75	SR87	SR85
Compatible servo drive	A4/A4N / A4NL/ A5 / A6 family	A4NL / A5 / A6 family	A4 / A4N / A4NL / A5 / A6 family	A4NL / A5 / A6 family
Effective length	70 mm to 2040 mm		140 mm to 3040 mm	
Accuracy	3+3 L/1000 μm p-p or 5+5 L/1000 μm p-p L = Effective length (mm)			
Resolution	A5 family: 0.01 μm to 1 μm A4 / A4N / A4NL: 0.05 μm to 1 μm			
Signal type	Absolute	Incremental	Absolute	Incremental
Response speed	2 m/s			
Output signal	Dedicated to MINAS series, serial output			
Origin signal	-	1 point	-	1 point
Protective design grade	IP54 (Without air purge), IP65 (With air purge)			

Provide high speed, high response, high reliability are secured through serial communication
CK-T185 conversion cable is required when connecting to A5, A6 family

Sales area

- Japan
- United States of America
- German

Language

- Japanese
- German
- English

Please contact the following address for details.

For more information

URL : <http://www.magnescape.com/mgs/language/english/>

Contact: **Magnescape Co., Ltd.**

3-1-4, Edagawa, Koto-ku, Tokyo, 135-0051, Japan

[E-mail: info-mgs@magnescape.com]

TEL: +81-3-6632-7923

Feedback Scale

SmartSCALE

Features

- Maximum response speed 3 m/s, Maximum resolution 0.05 μm, and ±5 μm accuracy
- Individual non-contact component design
- Space-saving small head (W 33 mm × D 16 mm × H 8 mm)
- Signal LED display for ease of installation

Separate type / Magnetic detection system
Incremental scale

SQ10 + PQ11
SQ10 + PQ10 + MQ10
(A5, A6 family)



- Please contact Panasonic for the combination of A6 series driver and feedback scale.

Specification

Item	Description	
Type	Separate type / Magnetic detection system Incremental scale	
Part No.	SQ10 + PQ11	SQ10 + PQ10 + MQ10
Configuration	SQ10 scale + PQ11head with interpolator	SQ10 scale + PQ10 interpolator + MQ10 head
Compatible servo drive	A5/A6 family	
Effective length	100 mm to 1000 mm	
Accuracy	±5 μm	
Resolution	0.05 μm / 0.1 μm / 0.5 μm / 1 μm	
Signal type	Incremental	
Response speed	3 m/s	
Output signal	Dedicated to MINAS series, Serial output	
Origin signal	1 point	
Protection grade	IP60 / IP65	

Provide high speed, high response, high reliability are secured through serial communication
CK-T185 conversion cable is required when connecting to A5, A6 family

Feedback Scale

BF1 series

Features

- High-resolution reflective Laserscale with signal wavelength of 250 nm
- Easy to check signal with LED
- Increase mounting tolerance enable easy installation. (Pitching/Rollin/Yawing : ±20 min)

High-resolution reflective type
Laserscale

BF1 series
(A5, A6 family)



- Please contact Panasonic for the combination of A6 series driver and feedback scale.

Specification

Item	Description
Type	High-resolution reflective type Laserscale
Part No.	BF1
Compatible servo drive	A5 / A6 family
Effective length	30 mm to 1400 mm
Accuracy	±0.5 μm (30 mm to 170 mm)/ ±1 μm (220 mm to 370 mm)/ ±3 μm (420 mm to 520 mm)/ ±5 μm (570 mm to 970 mm)/ ±10 μm (1070 mm to 1400 mm)
Resolution	0.001 μm / 0.01 μm
Signal type	Incremental
Response speed	0.4 m/s / 1.8 m/s
Output signal	Dedicated for MINAS series, serial output
Origin signal	1 point

Provide high speed, high response, high reliability are secured through serial communication
CK-T185 conversion cable is required when connecting to A5, A6 family

Sales area

- Japan
- United States of America
- German

Language

- Japanese
- German
- English

Please contact the following address for details.

For more information

URL : <http://www.magnescape.com/mgs/language/english/>

Contact: **Magnescape Co., Ltd.**

3-1-4, Edagawa, Koto-ku, Tokyo, 135-0051, Japan

[E-mail: info-mgs@magnescape.com]

TEL: +81-3-6632-7923

Linear scale

Open type Tape Scale

Features

Tape Scale with 0.4 mm thickness

- Unaffected by dust, oil, and condensation
- 0.1 μm detection at 1800 m / min with MINAS series serial I / F
- Non-contacting! Stable high accuracy lasted a long period
- Easy diagnostic such as GAP adjustment (with PC)

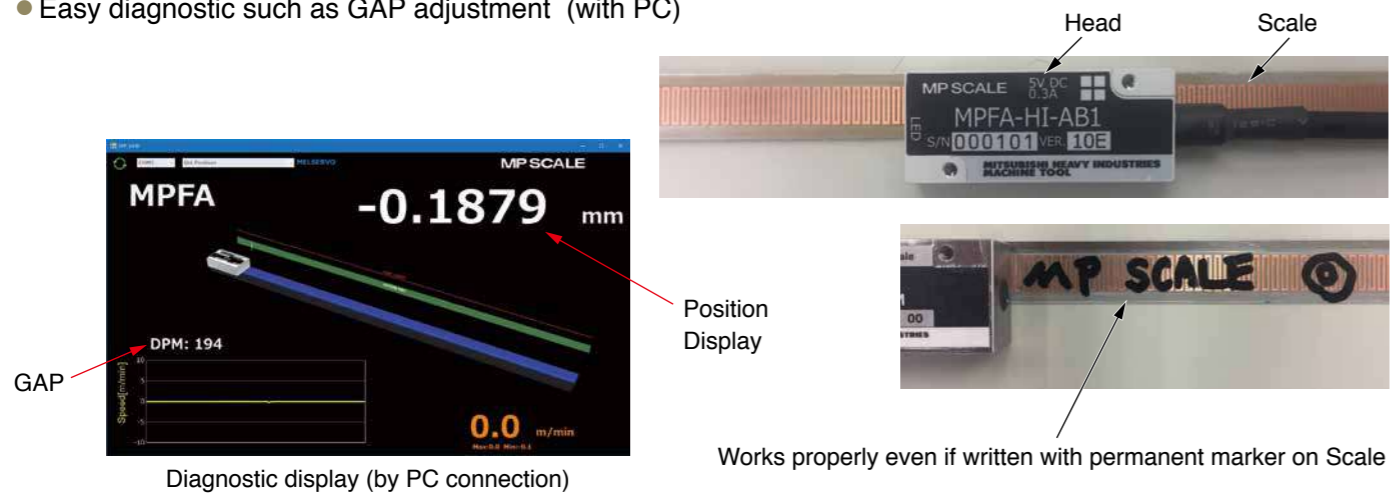

Application Sample

- Feedback for high precision linear stage
- Transport device with positioning function
- Wire cut electrical discharge machine

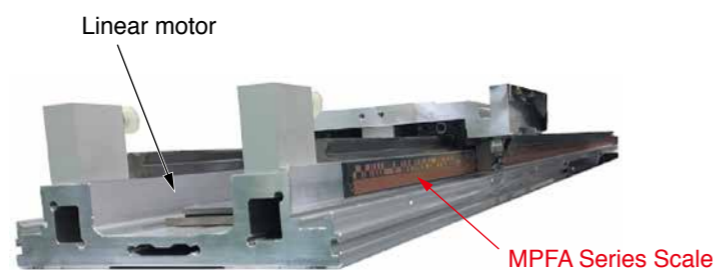

Linear motor drive stage with position feedback of MPFA Series Scale

Specification

Item	Contents
Resolution	0.1 μm, 1 μm
Speed	1800 m/min
Accuracy	±15 μm/m
Stroke	Up to 9950 mm (Full length-50mm)
Fixing method	Scale is tape type, bonded to the mounting surface.
Multi head	Possible
Output	Serial output and A, B, Z phase pulse

* Start of sale: December 2019. Please contact us for the latest information.

Absolute Open Type Rotary Scale

MPZA series, MPRZ series

Features

- High accuracy 2sec/MPRZ-18072A
- Unaffected by dust, oil, and condensation
- Non-contact ! High speed 10000 min⁻¹
- Keep High accuracy ! All over circumference pattern detection cancel detecting error caused by eccentricity.
- Large hollow up to 180 mm



Application Sample

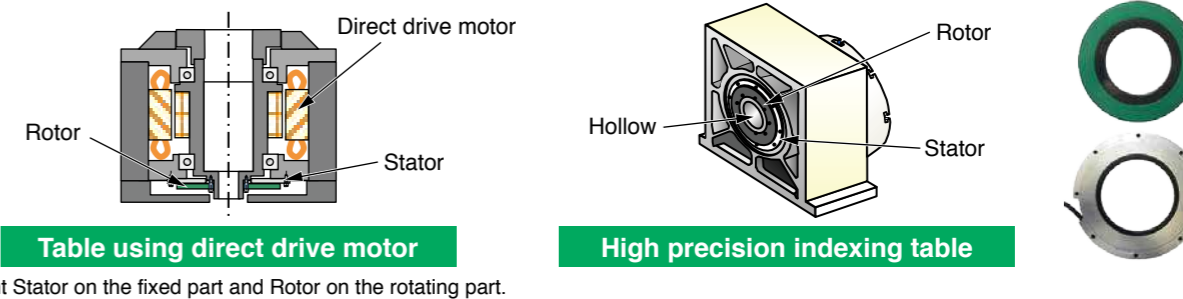

System Configuration

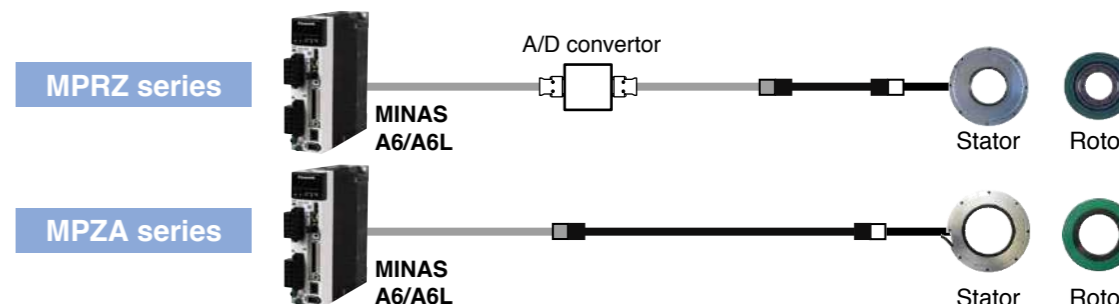

Specification

Scale type	Inner diameter	Outer diameter	Accuracy	Resolution	Speed
MPZA2024A	φ20 mm	φ110 mm	5 sec	2 ²³ /rev 0.043×10 ⁻³ degrees	10000 min ⁻¹
MPZA10036A	φ100 mm	φ200 mm	4 sec		
MPRZ-536A	φ27.1 mm	φ127.0 mm	4 sec	2 ²³ /rev 0.043×10 ⁻³ degrees	10000 min ⁻¹
MPRZ-736B	φ58.0 mm	φ177.8 mm	3 sec		
MPRZ-1036B	φ90.0 mm	φ251.7 mm	2.5 sec		
MPRZ-1236B	φ120.0 mm	φ302.0 mm	2 sec		
MPRZ-9636A	φ96.0 mm	φ200.0 mm	4 sec		
MPRZ-12536A	φ125.0 mm	φ230.0 mm	4 sec		
MPRZ-18072A	φ180.0 mm	φ340.0 mm	2 sec		5000 min ⁻¹

Sales area

- Japan • China • Taiwan • Korea

Language

- Japanese • English • Chinese • Korean

For more information

URL: <https://www.mhi-machinetool.com/en/index.html>

Contact: **MITSUBISHI HEAVY INDUSTRIES MACHINE TOOL CO., LTD MP Scale technical sales team**
Postal code 616-8114 No1, Uzumasa tatsumi-cho, Ukyo-ku, Kyoto Japan TEL:+81-75-861-3313 FAX: +81-75-861-3327

Linear Scale

ABS AT500 series /ST700 series/ST1300 series

Features

- Many years of experience that has opened up the absolute system solution in the world with collaboration of MINAS series originally.
- By changing from the Incremental scale system to the absolute scale, machine homing becomes unnecessary for AT500 and ST700 series.
- Absolute use, Photoelectric, Electromagnetic detection method, High resolution, High accuracy, non-contact type and so on support various applications widely.

ABS AT500 series

High Rigid SC type

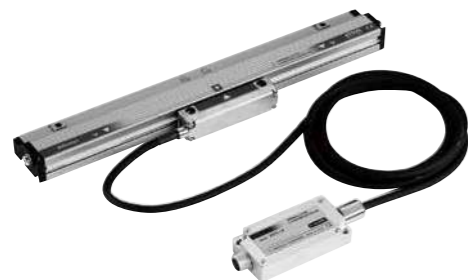

High Resolution H type

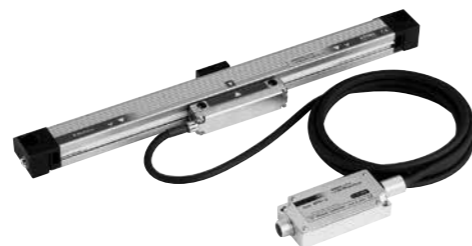

Specification

Item	Description	
	AT573-SC	AT573-H
Max. effective range	2200 mm	1000 mm
Resolution	0.05 μm	
Max. response rate	2.5 m/sec	
Accuracy (μm) : 20 °C	3 + 3 L/1000 μm *	2 + 2 L/1000 μm *
Vibration resistance	20 G	15 G
Shock resistance	35 G	20 G
Max. current consumption	270 mA	
Operation temperature	0 °C ~ 45 °C	

* Please refer to the catalog and manual issued by Mitutoyo.

* L = effective length mm

Application Sample

- Machining Center
- Lathe Machine
- Grinding Machine

ST700 series/ ST1300 series

ABS ST700 series Electromagnetic induction type



ABS ST1300 series Photoelectric type



Specification

Item	Description			
	ABS ST700		ABS ST1300	
Detection system	Electromagnetic induction type		Photoelectric type	
Scale type	Scale base	Glass Scale	Metal tape	
			Fixed at both ends	Double-sided tape
Max. effective range	6 m	1.1 m	12 m	3 m
Position accuracy (20 °C)	5 + 5 L/1000 μm *	3 + 3 L/1000 μm *	±5 μm (~1 m) ±5 μm/m (1.1 m~)	
Min. resolution	0.1 μm		0.001 μm / 0.01 μm	
Max. response speed	5 m/s		8 m/s	
Coefficient of thermal expansion	≈ 12 × 10 ⁻⁶ /K	≈ 8 × 10 ⁻⁶ /K	≈ 10 × 10 ⁻⁶ /K	

* L = Effective length mm

* Please refer to the catalog and manual issued by Mitutoyo.

Application Sample

- Semiconductor machine
- LCD manufacturing machine

Sales area and Language



North America area: **Mitutoyo America Corporation**
965 Corporate Blvd., Aurora, IL 60502, U.S.A.
TEL: +1-630-820-9666 Toll Free No.: +1-888-648-8869

Europe area: **Mitutoyo Europe GmbH**
Borsigstrasse 8-10, 41469 Neuss, GERMANY TEL: +49-2137-102-0

Other area: Please contact the following address for details. Or Please contact Mitutoyo JAPAN.

For more information

URL: <http://www.mitutoyo.co.jp/eng/>

Contact: **Mitutoyo Corporation Overseas Custom Equipment Sales Promotion Section**

[E-mail: kaigaitokuhan3@mitutoyo.co.jp]

20-1, Sakado 1-Chome, Takatsu-ku, Kawasaki-shi, Kanagawa 213-8533, Japan TEL: +81-44-813-8234

Optical Absolute Linear/Rotary Encoder

RESOLUTE™ series (Panasonic serial output)

Features

- True absolute encoder
- Resolution : 0.1 μm, 50 nm, 1 nm
- Velocity
- The industry's first unique signal-track scale
- Determines absolute position upon power-up
- Range of scales for a variety of applications
- Low SDE for smooth velocity control
- Worldwide subsidiary support network

Resolution	Panasonic A5 series	Panasonic A6 series
100 nm	40 m/s	100 m/s
50 nm	20 m/s	100 m/s
1 nm	0.4 m/s	4 m/s

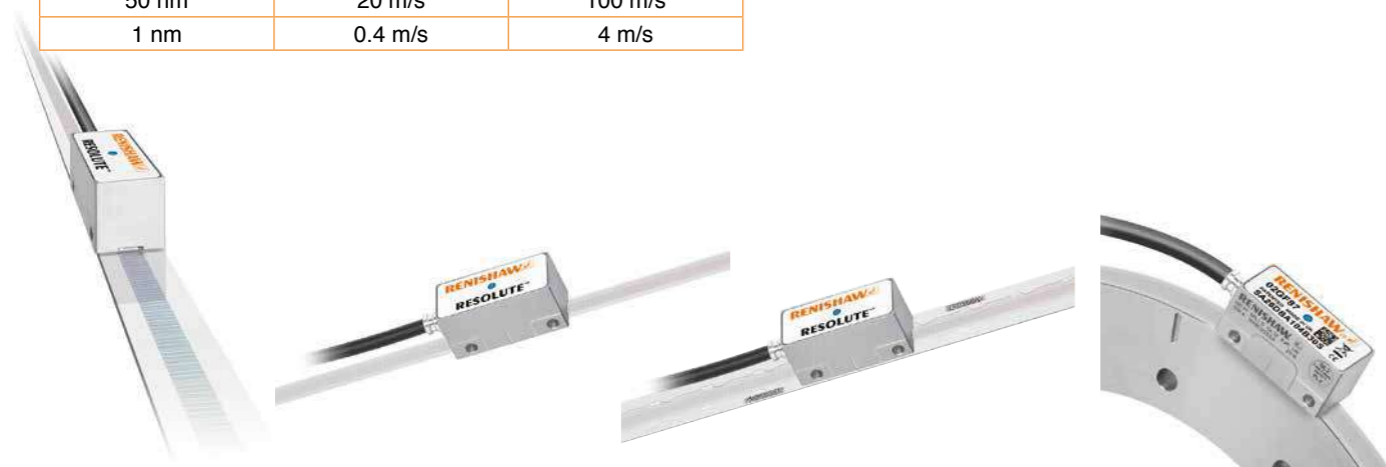

RESOLUTE™
RELA, RSLA

RESOLUTE™
RTLA-S

RESOLUTE™
FASTRACK/ RTLA

RESOLUTE™
RESA/REXA

Specification

Series Feature	RESOLUTE™ RELA	RESOLUTE™ RSLA	RESOLUTE™ RTLA-S	RESOLUTE™ FASTRACK/RTLA	RESOLUTE™ RESA/REXA
Scale	ZeroMet	Stainless steel	Stainless steel tape	Stainless steel tape	Stainless steel
Thermal expansion coefficient @ 20 °C	0.75 ±0.35 μm/m/°C	10.1 ±0.2 μm/m/°C	10.1 ±0.2 μm/m/°C	10.1 ±0.2 μm/m/°C	10.1 ±0.2 μm/m/°C
Scale accuracy @ 20 °C	±1 μm up to 1 m. ± 1 μm/m for lengths >1 m	±1.5 μm up to 1 m ±2.25 μm from 1 m to 2 m ±3 μm from 2 m to 3 m ±4 μm from 3 m to 5 m	±5 μm/m	±5 μm/m	±0.52 to ±5.49 arc second
Scale length	80 mm to 1500 mm	80 mm to 5000 mm	100 mm to 21000 mm	100 mm to 21000 mm	52 mm to 550 mm diameter
Scale mounting options	Self-adhesive or Clip/Clamp	Self-adhesive or Clip/Clamp	Self-adhesive	Track (carrier) mounting	Taper/flange mount
Read head size H x L x W	18 mm x 36 mm x 16.5 mm				
Scale size H x W	1.6 mm x 15 mm (clip/clamp) 1.8 mm x 15 mm Adhesive tape	1.5 mm x 15 mm (clip/clamp) 1.7 mm x 15 mm Adhesive tape	0.4 mm x 8 mm	0.4 mm x 18 mm	

Optical Incremental linear/Ring(Rotary) Encoder

TONiC, VIONiC & ATOM series (Digital & Analogue output signal)

Features

- Range of linear and rotary (ring or disc) scales for a variety of applications
- Easy installation and diagnostics using set-up LEDs
- Low Sub-Divisional Error (SDE) and Jitter
- IN-TRAC optical reference mark (Tonic)
- Auto-phased optical reference mark (ATOM)
- Resolution: 5 μm to 1 nm (TONiC)
5 μm to 2.5 nm (VIONiC)
10 μm to 1 nm (ATOM)
- Velocity : 6.48 m/sec @ 1 μm
0.648 m/sec @ 0.1 μm
(For clocked input frequency of 8 MHz)

VIONiC Series

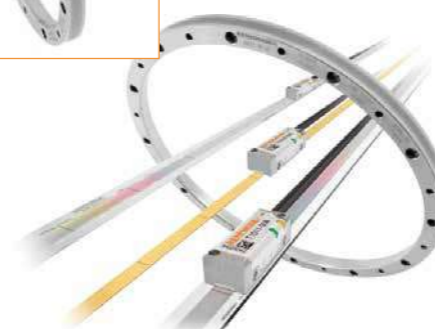

TONiC Series



ATOM Series

Application Sample

Our encoder are suitable to use in a variety of applications that require high positioning accuracy and speed stability.

Semiconductor

Flat Panel Display

Motion Control

Medical

Precision Measurements

Machine Tool

Industrial Robot

Science

Sales area

- Japan
- United Kingdom
- Worldwide response

Please contact the following address for details.

Language

For more information

URL: <http://www.renishaw.jp/> (Japanese)
<http://www.renishaw.com/> (English)

Contact: **Renishaw plc**

New Mills Wotton-under-Edge Gloucestershire GL12 8JR, United Kingdom

[E-mail: international@renishaw.com]

TEL:+44-1453-524524

Absolute Exposed Linear encoder

MC 15 series

Features

- Absolute linear encoder for measuring lengths up to 6 m (upon request)
- Very compact (36 x 13.5 x 14.8) and light scanning head (scanning head mass <18 g without connecting cable)
- High traversing speed and high resolution (10 m/sec, 50 nm)
- Wide mounting tolerances (nominal gap ± 0.25 mm)



MC 15P MP:
steel scale tape is drawn into the aluminum extrusions and fixed at center



MC 15P MK:
Steel scale tape cemented on mounting surface

Specification

	MC 15P MP	MC 15P MK
Measuring standard Coefficient of linear expansion	Steel scale tape with absolute track ≈ 10 ppm/K	
Accuracy grade	±15 μm	
Resolution	50 nm, 100 nm	
Measuring Length ML (mm)	Up to 3000 mm Longer lengths on request	
Interface	Panasonic Serial Interface (Pana01)	
Voltage supply	DC 3.6 V ~ 14 V	
Operating temperature	-10 °C ~ 50 °C	
Mounting method	Aluminum extrusion and fixed at center	Cemented on mounting surface

Absolute Angle Encoder without Integral Bearing

MCR 15 series

Features

- Absolute angle encoder
- Steel scale drum with three-point centering
- Large hollow shaft
- Panasonic Serial Interface (Pana01)



MCR 15P

Specification

		MCR 15P									
Measuring standard CTE		Steel drum with absolute track ≈ 16 ppm/K									
Drum size in mm	inside diameter	40	55	80	95	130	180	209	230	280	330
	outside diameter	59.93	75.1	100.0	114.2	150.4	200.4	228.8	249.9	299.8	350.2
System Accuracy		±20"	±15"	±10"							
Resolution (bit)		22	23	24				25			
Protection degree IEC60529		IP40 only for scanning head									

Sales area

- Japan
- United States of America
- German
- China
- All over the world

Language

- English
- German
- Japanese
- Chinese

For more information

URL : <http://www.heidenhain.de>

The incremental linear encoder of a magnetic type

SENSOR / PSLH Series, SCALE / PSLG Series

Features

This encoder has achieved an excellent total performance.

- It is high-speed serial communications corresponding to the MINAS series.
- This encoder is strong in the environment of the magnetic noise, oil, and dust.
- A miniaturization and an excellent cost performance are achieved by the internal manufacturing of the MR element.
- Accuracy is improved by an original magnetization pattern.
- It is a tough encoder structure in the extrinsic noise.



Specification

Item	Description
Model number	sensor PSLH040 + scale PSLG040
Output signals	MINAS series serial output
Resolution (R)	0.1 μm
Power supply voltage	4.6 V _{DC} to 5.5 V _{DC}
Power consumption	250 mA max
Gap of detection	0.25 mm ±0.1 mm
Maximum response speed	6 m/sec
IP code	Correspond to IP50
Detection of reference	Correspond up to three places
Position accuracy	±(5+5×L/1000) μm L=Measuring length (mm) at 20 °C
Measuring length (L)	2400 mm MAX
Thermal expansion coefficient	11.0×10 ⁻⁶ / °C
Operating temperature range	0 °C to 50 °C
Preservation temperature range	-15 °C to 70 °C

Another specifications of resolution, the size of the detection head, and the ABZ output, etc. can correspond.

Sales area

- Japan
- Worldwide response

Please contact the following address for details.

For more information

URL: <http://www.nidec-sankyo.co.jp/>

Contact: **NIDEC SANKYO CORPORATION**

Tokyo Office, Nidec Tokyo Bldg., 1-20-13, Osaki, Shinagawa-ku, Tokyo 141-0032, Japan

[E-mail: sensor-sales@nidec-sankyo.co.jp]

TEL: +81-3-5740-3006 FAX: +81-3-6843-3123

Feed back scale selection

Feed back scale table for serial communication

Scale Type	Partner	Series	Resolution*1 [μm]	Max. rate*1 [m/s]	
Parallel Type (A/B/Z phase)	General	—	Maximum speed after 4x multiplication : 4 Mpps		
Serial communication (Absolute)	FAGOR AUTOMATION	S2AP/SV2AP/G2AP	0.01/0.05	3	
		LAP	0.01/0.05	3	
		EXA/ EXG/ EXT	0.01/0.05	8	
		H2AP-D200/H2AP-D90	29 bit/23 bit	750 r/min/1500 r/min	
		S2AP-D170,/S2AP-D90	23 bit	1500 rpm	
	HEIDENHAIN	LIC 2197P/LIC 2199P	0.05/0.1	10	
		LIC 4193P/LIC 4195P LIC 4197P/LIC 4199P	0.001/0.005/0.01	10	
		LC 195P/LC 495P	0.001/0.01	3	
		ECA 4490P	27 bits to 29 bits	7000 r/min~550 r/min (Depends on drum size)	
		RCN 2x90P/RCN 5x90P	26 bits/28 bits	1500 r/min	
		RCN 8x90P	29 bit	500 r/min	
		RSF Elektronik	MC 15P MP/MC 15P MK	0.05/0.1	10
		Magnescale Co.,Ltd.	SR77	0.01 to 1	3.3
			SR87	0.01 to 1	3.3
		MITSUBISHI HEAVY INDUSTRIES MACHINE TOOL CO., LTD	MPZA/MPRZ	23 bits	10000 r/min, 5000 r/min
	AT573-SC/AT573-H		0.05	2.5	
	ST700		0.1	5	
	Mitutoyo Corporation	ST1300	0.001/0.01	8	
		Renishaw plc	RESOLUTE	0.001	A5/0.4, A6/4
				0.05	A5/20, A6/100
0.1	A5/40, A6/100				
Serial communication (Incremental)	Magnescale Co., Ltd.	SL700+PL101RP/RHP	0.1	10	
		SL710+PL101RP/RHP	0.1	10	
		SR75/SR85	0.01 to 1	3.3	
		BF1	0.001/0.01	0.4/1.8	
		SQ10+PQ11	0.05/0.1/0.5/1	3	
	MITSUBISHI HEAVY INDUSTRIES MACHINE TOOL CO., LTD	Nidec Sankyo Corporation	SQ10+PQ10+MQ10	0.05/0.1/0.5/1	3
			MPLIN	0.1	30
	Renishaw plc	PSLH041+PSLG	TONIC	0.001 to 5	6.48 m/s @ 1 μm 0.648 m/s @ 0.1 μm
			ATOM	0.001 to 10	
			VIONIC	0.0025 to 5	

Feed back scale application example

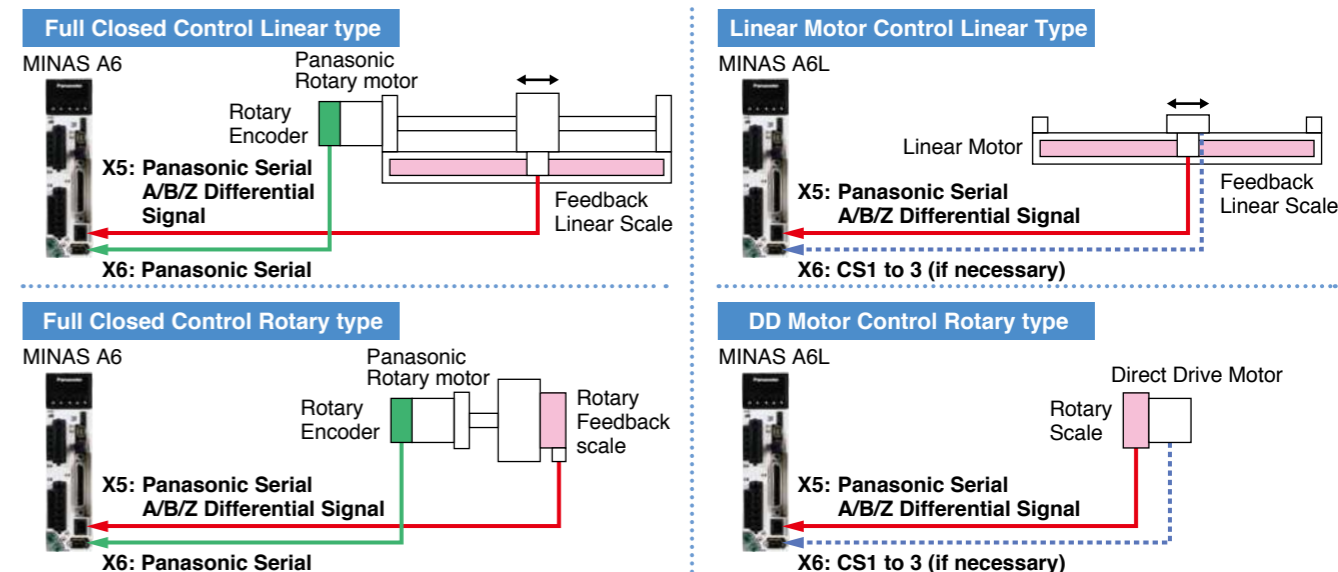

*1 There is the difference of resolution and maximum rate from the specification by original supplier as per the servo driver limitation of maximum pulse frequency. The maximum pulse frequency is 400 Mpps for A5 family and 4 Gpps for A6 series. We show the value of A6 family on this table.

- Please contact us when you study the system with a scale because the driver and the scale combination has restriction as per the feedback system between full closed control system and linear system.

AC Servo Actuator SHA-P Series

Features

- The SHA series incorporates the speed reducer HarmonicDrive®, for high precision motion control, to the flat AC servo motor.
- The design of the SHA series is flat and has hollow shaft structure. Piping, wiring, laser light, etc., can be passed through the through-hole in the center.
- Precise one-way positioning accuracy: Gear Ratio 50:1 = 40 arc-sec (0.011 degrees) Gear Ratio 80:1 and higher =30 arc-sec (0.008 degrees) (for SHA32P/40P-CG types)
- Torque-volume ratio is 5 times or more than that of direct drive motor.
- There are two types of option; SHA-SG type, which has compact shape feature, or SHA-CG type, which has improved output flange runout accuracy.

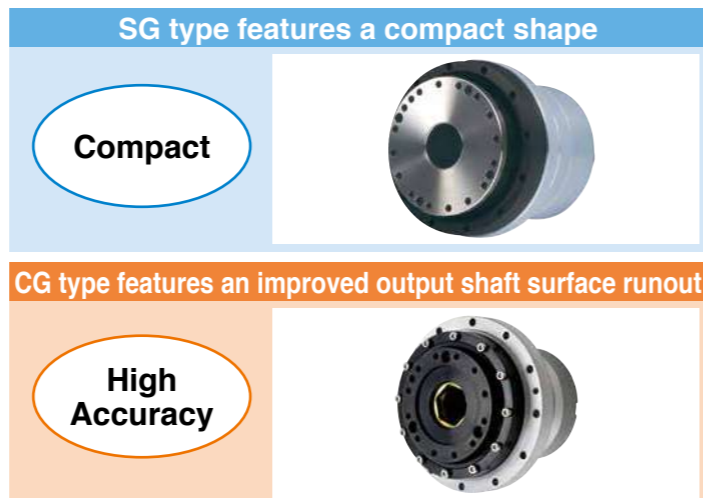
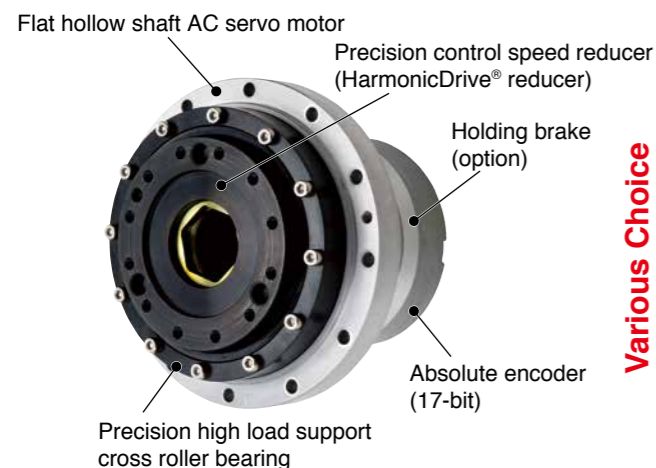

Max. Torque Mapping

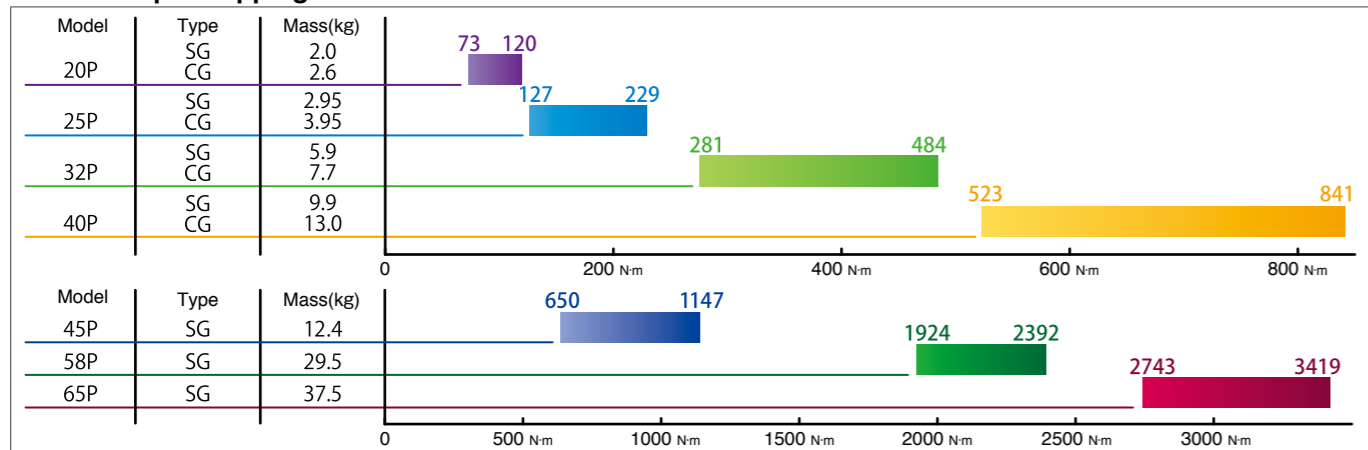

Specification

SHA-SG Type

Item	Model	SHA20P					SHA25P					SHA32P					SHA40P				
		51	81	101	121	161	51	81	101	121	161	51	81	101	121	161	51	81	101	121	161
Recommended Amplifier ^{*1,2,3}	A6N series	MBDL■25N□(All)					MBDL■25N□(161) MCDL■35N□(51~121)					MCDL■35N□(161) MDDL■45N□(121) MDDL■55N□(51~101)					MDDL■55N□(81~161) MEDL■83N□(51)				
	A6B series	MBDL■25B□(All)					MBDL■25B□(161) MCDL■35B□(51~121)					MCDL■35B□(161) MDDL■45B□(121) MDDL■55B□(51~101)					MDDL■55B□(81~161) MEDL■83B□(51)				
	A6S series	MBDL■25S□(All)					MBDL■25S□(161) MCDL■35S□(51~121)					MCDL■35S□(161) MDDL■45S□(121) MDDL■55S□(51~101)					MDDL■55S□(81~161) MEDL■83S□(51)				
Maximum Torque	N·m	73	96	107	113	120	127	178	204	217	229	281	395	433	459	484	523	675	738	802	841
Maximum Speed	r/min	117.6	74.1	59.4	49.6	37.3	109.8	69.1	55.4	46.3	34.8	94.1	59.3	47.5	39.7	29.8	78.4	49.4	39.6	33.1	24.8
Maximum Moment Load	N·m	187					258					580					849				
One-Way Positioning Accuracy	arc sec	60	50	50	50	50	50	40	40	40	40	50	40	40	40	40	50	40	40	40	40
Mass (without brake)	kg	2.0					2.95					5.9					9.9				

Specification

SHA-SG Type

Item	Model	SHA45P					SHA58P				SHA65P			
		51	81	101	121	161	81	101	121	161	81	101	121	161
Recommended Amplifier ^{*1,2,3}	A6N series	MDDL■55N□(161) MEDL■83N□(51~121)					MEDL■93N□(161) MFDL■A3N□(81~121)				MFDL■A3N□(161) MFDL■B3N□(81~121)			
	A6B series	MDDL■55B□(161) MEDL■83B□(51~121)					MEDL■93B□(161) MFDL■A3B□(81~121)				MFDL■A3B□(161) MFDL■B3B□(81~121)			
	A6S series	MDDL■55S□(161) MEDL■83S□(51~121)					MEDL■93S□(161) MFDL■A3S□(81~121)				MFDL■A3S□(161) MFDL■B3S□(81~121)			
Maximum Torque	N·m	650	918	982	1070	1147	1924	2067	2236	2392	2743	2990	3263	3419
Maximum Speed	r/min	74.5	46.9	37.6	31.4	23.6	37.0	29.7	24.8	18.6	34.6	27.7	23.1	17.4
Maximum Moment Load	N·m	1127					2180				2740			
One-Way Positioning Accuracy	arc sec	50	40	40	40	40	40	40	40	40	40	40	40	40
Mass (without brake)	kg	12.4					29.5				37.5			

SHA-CG Type

Item	Model	SHA20P					SHA25P				SHA32P				SHA40P						
		50	80	100	120	160	50	80	100	120	160	50	80	100	120	160	50	80	100	120	160
Recommended Amplifier ^{*1,2,3}	A6N series	MBDL■25N□(All)					MBDL■25N□(160) MCDL■35N□(50~120)				MCDL■35N□(160) MDDL■45N□(120) MDDL■55N□(50~100)				MDDL■55N□(80~160) MEDL■83N□(50)						
	A6B series	MBDL■25B□(All)					MBDL■25B□(160) MCDL■35B□(50~120)				MCDL■35B□(160) MDDL■45B□(120) MDDL■55B□(50~100)				MDDL■55B□(80~160) MEDL■83B□(50)						
	A6S series	MBDL■25S□(All)					MBDL■25S□(160) MCDL■35S□(50~120)				MCDL■35S□(160) MDDL■45S□(120) MDDL■55S□(50~100)				MDDL■55S□(80~160) MEDL■83S□(50)						
Maximum Torque	N·m	73	96	107	113	120	127	178	204	217	229	281	395	433	459	484	523	675	738	802	841
Maximum Speed	r/min	120	75	60	50	37.5	112	70	56	46.7	35	96	60	48	40	30	80	50	40	33.3	25
Maximum Moment Load	N·m	187					258				580				849						
One-Way Positioning Accuracy	arc sec	60	50	50	50	50	50	40	40	40	40	40	30	30	30	30	40	30	30	30	30
Repeatability	arc sec	±5					±5				±4				±4						
Bi-directional Repeatability	arc sec	75	30	30	30	30	60	25	25	25	25	60	25	25	25	25	50	20	20	20	20
Mass (without brake)	kg	2.6					3.95				7.7				13						

The table shows typical output values of actuators.
 *1 ■ in the amplifier code indicates the safety function.
 T : With safety function
 N : Without safety function

*2 □ in the amplifier code indicates driver specification.
 E : Standard type
 F : Multi-function type
 G : Communication type
 *3 Numbers in () indicates applicable reduction ratio.

External Dimensions

SHA-SG type

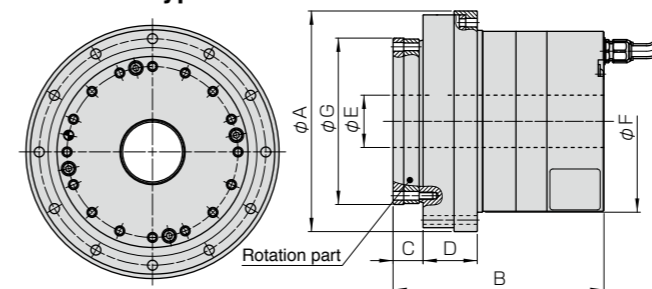

SHA-CG type

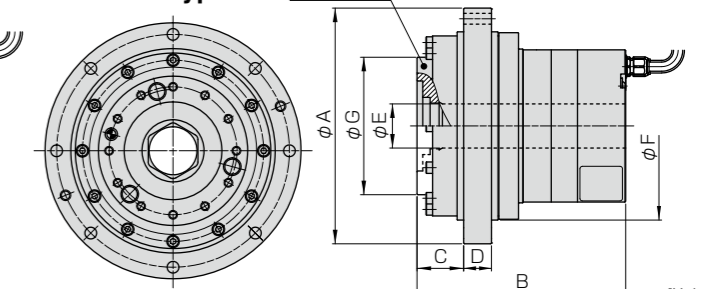

Item	Model	SHA20P		SHA25P		SHA32P		SHA40P		SHA45P	SHA58P	SHA65P
		SG type	CG type	SG type	CG type	SG type	CG type	SG type	CG type	SG type	SG type	SG type
φA		94	117	114	144	146	175	175	225	195	247	284
B		108.5	125.5	109	127.5	125	144	148	170	153.5	213	222
C		15.5	26	15.5	28.5	20	34	26	40	28	37	42.5
D		27	14	28	17	34.5	20	42	22	45.5	74	77.5
φE (Hollow)		17	17	27	27	35	35	45	45	45	65	65
φF		77 h7	95 h7	94 h7	115 h7	122 h7	148 h7	145 h7	180 h7	164 h7	210 h7	236 h7
φG		54 h7	69 h7	86 h7	84 h7	114 h7	110 h7	140 h7	132 h7	160 h7	203 h7	223 h7

Application Sample

URL : <http://www.hds.co.jp/english/products/application/>

Please refer to the sample and typical applications for the SHA-P Series with Panasonic Servo as shown in the URL above.

Sales area

- Japan
- Global

Language

- Japanese
- English
- Chinese

Contact: **Harmonic Drive Systems Inc. Overseas Division**

1856-1 Hotakamaki, Azumino-shi, Nagano, 399-8305, Japan

TEL: +81-263-83-6935 FAX: +81-263-83-6901

AC Servo Actuator

FHA-Cmini Series

Features

- The FHA-C mini series incorporates the small speed reducer HarmonicDrive®, for high precision motion control, to the flat AC servo motor.
- Three types in outer square size (8C: 50 mm, 11C: 60 mm, 14C: 75 mm) contribute to simplify the equipment structure.
- The thin speed reducer HarmonicDrive® for precision control assures very high torque output compare to a direct drive motor of the same size.
- Three reduction ratio (1/30, 1/50, 1/80) are available.

Precision control speed reducer
(HarmonicDrive® reducer)

Flat AC servo motor

Precision high load support
cross roller bearing

Absolute encoder(17-bit)

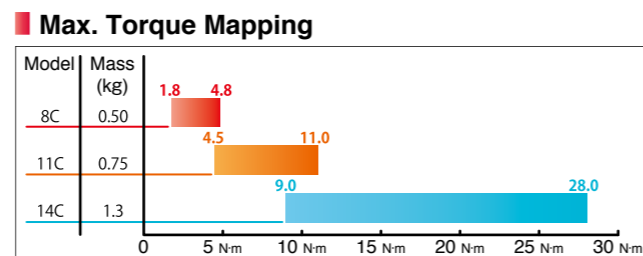

Specification

Item	Model	FHA-8C			FHA-11C			FHA-14C		
		30	50	100	30	50	100	30	50	100
Recommended Amplifier *1*2	A6N series	MADL 05N (All)			MADL 05N (All)			MADL 05N (50,100) MADL 15N (30)		
	A6B series	MADL 05B (All)			MADL 05B (All)			MADL 05B (50,100) MADL 15B (30)		
	A6S series	MADL 05S (All)			MADL 05S (All)			MADL 05S (50,100) MADL 15S (30)		
Maximum Torque	N·m	1.8	3.3	4.8	4.5	8.3	11	9	18	28
Maximum Speed	r/min	200	120	60	200	120	60	200	120	60
Maximum Moment Load	N·m	15			40			75		
One-Way Positioning Accuracy	arc sec	150	120	120	120	90	90	120	90	90
Mass (without brake)	kg	0.50			0.75			1.3		

The table shows typical output values of actuators.

*1 ■ in the amplifier code indicates the safety function.
T : With safety function
N : Without safety function

*2 □ in the amplifier code indicates driver specification.

E : Standard type
F : Multi-function type
G : Communication type

*3 Numbers in () indicates applicable reduction ratio.

External Dimensions

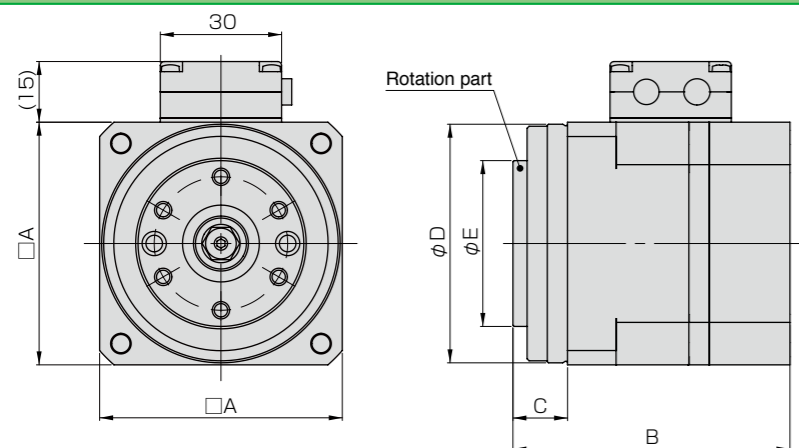

Item	Model	FHA-8C	FHA-11C	FHA-14C
A	□	50	60	75
B		61.8	68.5	78
C		13	13.5	18.5
φD		49 h7	59 h7	74 h7
φE		33.5 h7	41 h7	52.5 h7

AC Servo Motor

PMA Series

Features

- The hollow shaft design provides the piping/wiring layout on the center of rotation without offsetting the motor.
- The flat structure reduces the size of the device configuration.
- A wide variety of five sizes with the rated output from 163 W to 1320 W has been added to the lineup.
- Integrated brake option is available without dimension change.

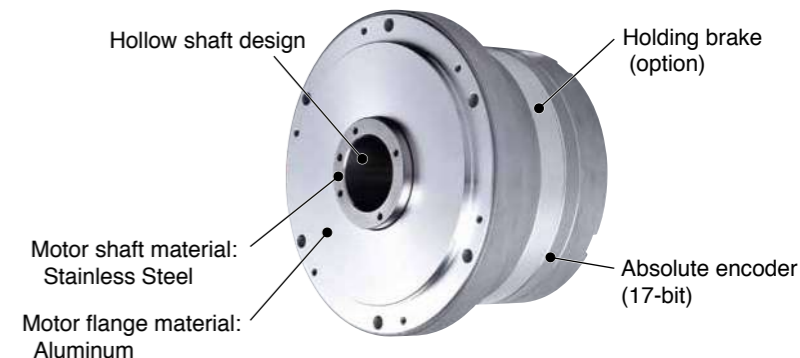

Specification

Model		PMAC08	PMAB09	PMAB12	PMAB15	PMAA21A
Recommended Amplifier *1*2	A6N series	MBDL 25N □	MCDL 35N □	MDDL 55N □	MEDL 83N □	MFDL B3N □
	A6B series	MBDL 25B □	MCDL 35B □	MDDL 55B □	MEDL 83B □	MFDL B3B □
	A6S series	MBDL 25S □	MCDL 35S □	MDDL 55S □	MEDL 83S □	MFDL B3S □
Rated output	W	163	251	406	754	1320
Maximum Torque	N·m	1.8	3	7	13	45
Maximum Speed	r/min	6000	5600	4800	4000	3000
Mass (without brake)	kg	1.4	2.0	3.4	5.5	17.5

The table shows typical output values of actuators.

*1 ■ in the amplifier code indicates the safety function.
T : With safety function
N : Without safety function

*2 □ in the amplifier code indicates driver specification.

E : Standard type
F : Multi-function type
G : Communication type

External Dimensions

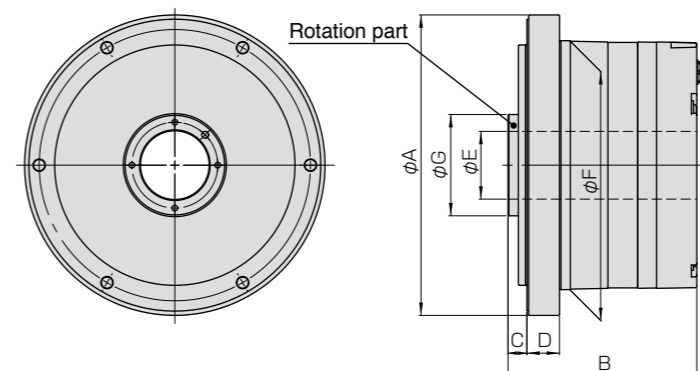

Model	PMAC08	PMAB09	PMAB12	PMAB15	PMAA21A
φA	94	114	146	175	247
B	89	88.5	95.5	110	157
C	10	10	10	11	16
D	13	13	15	19	39
φE	16	22	30	40	60
φF	77 h7	94 h7	122 h7	145 h7	210 h7
φG	28 h6	34 h6	43 h6	59 h6	88 h6

Application Sample

URL : <http://www.hds.co.jp/english/products/application/>

Please refer to the sample and typical applications for the SHA-P Series with Panasonic Servo as shown in the URL above.

Sales area

• Japan • Global

Language

• Japanese • English • Chinese

Contact: **Harmonic Drive Systems Inc. Overseas Division**

1856-1 Hotakamaki, Azumino-shi, Nagano, 399-8305, Japan

TEL: +81-263-83-6935 FAX: +81-263-83-6901

Compact Actuator AF series

AF017N/042N/080N/125N/380N/500N/050C/120C/200C/320C

Features

- **High precision, stiffness, quality**
Integrating Panasonic servo motors with large industrial robot market share Precision Reduction Gear RV
- **Compact**
Compact drive unit is made possible by machining gear directly onto motor shaft
- **High versatility**
Compatible with the MINAS-A5/A6 family of standard servo drivers



Compact design

Merit 1 Before **After**
The total length is extended due to the input gear and coupling. **With the AF series...** The machining of gears onto the motor shaft results in a very compact design; **up to 23% shorter than conventional models.**

Greater reliability

Merit 2 Before **After**
Machining is very difficult, resulting in axial runout, poor concentricity accuracy, and producing abnormal noise. **With the AF series...** Shipped after machining and assembly, **no need to worry about abnormal noise.**

Greater quality

Merit 3 Before **After**
O-ring or liquid sealant **With the AF series...** Greasing can be troublesome, If seals are forgotten, grease can leak. **Already contains grease; no need to worry about leaking.**

Specification

Motor series: MINAS A6

Item	Model	Solid type						
		AF017N	AF042N	AF080N	AF125N	AF500N		
Actuator								
Motor model		MHMF042	MDMF102	MDMF102	MDMF152	MDMF202	MHMF302	MDMF402
Motor rated capacity	kW	0.4	1.0	1.0	1.5	2.0	3.0	4.0
Speed ratio		81	126	126	126	129	102.18 (1737/17)	252.33 (757/3)
Rated torque	Nm	82 ^{*2}	415	481	722	986	1169	3856
Momentary max. torque	Nm	289	415	1029	1029	1960	3062	11567
Rated output speed	min ⁻¹	37.0	15.9	15.9	15.9	15.5	19.6	7.9
Momentary max. speed	min ⁻¹	80.2	31.7	31.7	31.7	31.0	39.1	15.1
Allowable load inertia moment	kgm ²	11	117	117	164	221	473	3311
Backlash	arc.min.	≤ 1	≤ 1	≤ 1	≤ 1	≤ 1	≤ 1	≤ 1
Motor brake		With / Without	With	With	With	With	With	With
Allowable moment	Nm	784	784	1660	1660	2150	3430	11000
mass	kg	7.2/6.8	15	16	17	26	39.7	91.1
Motor torque limit ^{*1}	%	350	86	214	142	198	261	300

Compatible servo driver								
A6SE : Basic type	MDDL25SE***	MDDL45SE***	MDDL45SE***	MDDL55SE***	MEDLN83SE***	MFDLNA3SE***	MFDLNB3SE***	
A6SG : RS485 communication type	MDDL25SG***	MDDL45SG***	MDDL45SG***	MDDL55SG***	MEDLN83SG***	MFDLNA3SG***	MFDLNB3SG***	
A6SF : Multifunction type	MDDL25SF***	MDDL45SF***	MDDL45SF***	MDDL55SF***	MEDLT83SF***	MFDLTA3SF***	MFDLTB3SF***	
A6NE : RTEX network standard type	MDDL25NE***	MDDL45NE***	MDDL45NE***	MDDL55NE***	MEDLN83NE***	MFDLNA3NE***	MFDLNB3NE***	
A6NF : RTEX network multi function	MDDL25NF***	MDDL45NF***	MDDL45NF***	MDDL55NF***	MEDLT83NF***	MFDLTA3NF***	MFDLTB3NF***	
A6BE : EtherCAT network standard type	MDDL25BE***	MDDL45BE***	MDDL45BE***	MDDL55BE***	MEDLN83BE***	MFDLNA3BE***	MFDLNB3BE***	
A6BF : EtherCAT network multi function	MDDL25BF***	MDDL45BF***	MDDL45BF***	MDDL55BF***	MEDLT83BF***	MFDLTA3BF***	MFDLTB3BF***	

*1 Set the torque limit of the servo amplifier so that the torques does not exceed the momentary maximum torque of the compact actuator.
*2 Value calculated from the rated torque of the motor where the ambient temperature is 20 °C. When the ambient temperature is 40 °C, the torque will be 75 % of the rated torque.

Specification

Motor series: MINAS A6

Item	Model	Hollow shaft type		
		AF050C	AF120C	AF320C
Actuator				
Motor model		MDMF102	MDMF202	MHMF502
Motor rated capacity	kW	1.0	2.0	5.0
Speed ratio		120.47(2289/19)	120	157
Rated torque	Nm	460	917	3002
Momentary max. torque	Nm	1225	2746	7840
Rated output speed	min ⁻¹	16.6	16.7	12.7
Momentary max. speed	min ⁻¹	33.2	33.3	22.3
Allowable load inertia moment	kgm ²	84	158	1763
Backlash	arc.min.	≤ 1	≤ 1	≤ 1
Motor brake		Without	Without	With
Allowable moment	Nm	1764	3920	20580
mass	kg	32	43	164
Motor torque limit ^{*1}	%	266	299	261

Motor series: MINAS A5

Item	Model	Solid type				Hollow shaft type	
		AF042N	AF125N	AF380N	AF500N	AF200C	AF320C
Actuator							
Motor model		MDME102SC	MHME302SC	MDME402SC	MDME402SC	MDME302SC	MDME502SC
Motor rated capacity	kW	1.0	3.0	4.0	4.0	3.0	5.0
Speed ratio		93	102.18 (1737/17)	217.86 (1525/7)	252.33 (757/3)	155.96	157
Rated torque	Nm	355	1169	3329	3856	1784	3002
Momentary max. torque	Nm	1029	3062	9310	11567	4900	7840
Rated output speed	min ⁻¹	21.5	19.6	9.2	7.9	12.8	12.7
Momentary max. speed	min ⁻¹	32.3	29.4	13.8	11.9	19.2	19.1
Allowable load inertia moment	kgm ²	51	371	2026	2713	303	1216
Backlash	arc.min.	≤ 1	≤ 1	≤ 1	≤ 1	≤ 1	≤ 1
Motor brake		With	With	With	With	With	With
Allowable moment	Nm	1660	3430	7050	11000	8820	20580
mass	kg	17	40	77	93	116	163
Motor torque limit ^{*1}	%	289	261	279	300	274	261

*1 Set the torque limit of the servo amplifier so that the torques does not exceed the momentary maximum torque of the compact actuator.

Application Sample



Sales area

- Japan
- All over the world

Language

- Japanese
- Chinese
- English

For more information

URL: <https://precision.nabtesco.com/>

Contact: Nabtesco Corporation

Europe and Africa:	[E-mail: info@nabtesco.de]	TEL: +49-211-173790
North and South America:	[E-mail: engineer@nabtescomotioncontrol.com]	TEL: +1-248-553-3020
China:	[E-mail: info@nabtesco-motion.cn]	TEL: +86-21-3363-2200
India:	-	TEL: +91-80-4123-4901
Asia and others:	[E-mail: P_information@nabtesco.com]	TEL: +81-6-6341-7180

Precision Positioning Stage

PG Series / KX Series / KXS Series.

Features

- Combine MINAS A6 family (EtherCAT/RTEX supported) with Precision Positioning Stages.
- Ideal for automation process which requires high precision.
- Compact, high rigidity, broad range of travel length selection, weight multiplication accuracy $\pm 0.5 \mu\text{m}$.
- Supporting long travel length (up to 500 mm) and high load capacity.

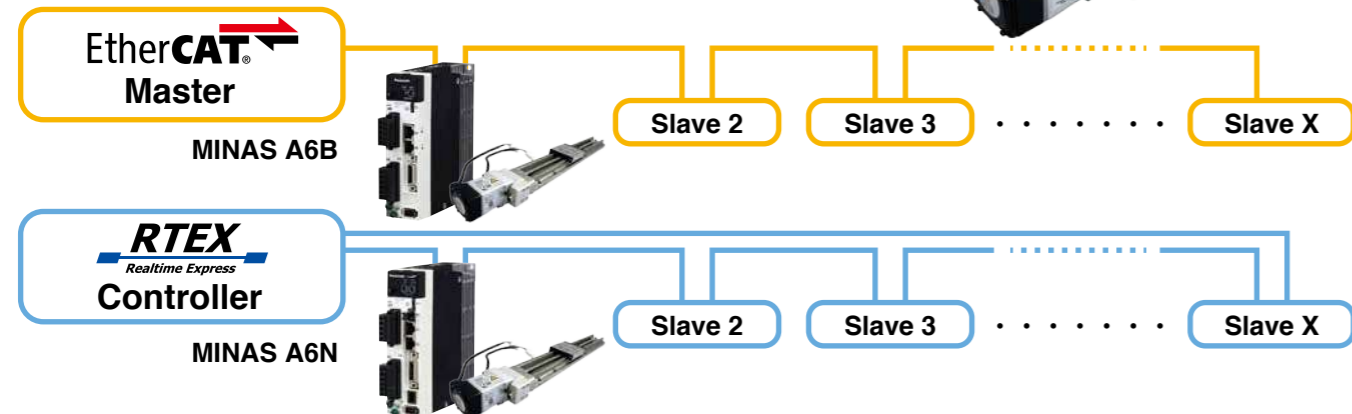

Specification

PG Series

Compact

High Rigidity



Item	Description	
Travel length	13 / 15 / 30 / 50 mm	
Table size	40 x 40 mm ~ 70 x 110 mm	
Ball screw	Shaft diameter	$\phi 6 \text{ mm}$
	Lead	1 mm
Main materials	Stainless	
Finishing	Electroless nickel plating	
Resolution (Pulse)	23 bit encoder (8388608 P/R)	
Accuracy	Uni-directional positioning accuracy	$6 \mu\text{m}/13 \text{ mm} \sim 12 \mu\text{m}/50 \text{ mm}$
	Repeatability	$\pm 0.5 \mu\text{m}$
	Max Speed	50 mm/sec
	Load capacity	10 kgf (98 N)

(Note) Accuracy specifications are for reference only.

KXL Series

Broad Selection

High Rigidity



Item	Description	
Travel length	30/50/75/100/150/200/300 mm	
Table size	60 x 60 mm	
Ball screw	Shaft diameter	$\phi 6 \text{ mm}$
	Lead	1 mm (TL: 30 mm ~ 75 mm) / 2 mm (TL: 30 mm ~ 300 mm)
Main materials	Stainless	
Finishing	Electroless nickel plating	
Resolution (Pulse)	23 bit encoder (8388608 P/R)	
Cover	Covered / Uncovered	
Accuracy	Uni-directional positioning accuracy	$5 \mu\text{m}/30 \text{ mm} \sim 25 \mu\text{m}/300 \text{ mm}$
	Repeatability	$\pm 0.5 \mu\text{m}$
	Max Speed	50 mm/sec / 100 mm/sec
	Load capacity	12 kgf (117.6 N)

(Note) Accuracy specifications are for reference only.

KXS Series

Long stroke

High load capacity



Item	Description	
Travel length	100/200/300/400/500 mm	
Table size	180 x 180 mm	
Ball screw	Shaft diameter	$\phi 15 \text{ mm}$
	Lead	5 mm / 10 mm
Main materials	Aluminum	
Finishing	Anodic oxide coating	
Resolution (Pulse)	23 bit encoder (8388608 P/R)	
Cover	Covered / Uncovered	
Accuracy	Uni-directional positioning accuracy	$5 \mu\text{m}/100 \text{ mm} \sim 40 \mu\text{m}/500 \text{ mm}$
	Repeatability	$\pm 1 \mu\text{m}$
	Max Speed	200 mm/sec / 400 mm/sec
	Load capacity	30 kgf (294 N)

(Note) Accuracy specifications are for reference only.

[Applicable drive / motor type] A6 family Drive : M*DL* * * * * Motor : M*MF* * * L* * * *
Please contact the following address for the details of the combination.

Application Sample

Lens alignment device

XY Stage for microscope

Wafer inspection unit

Glass substrate evaluation unit

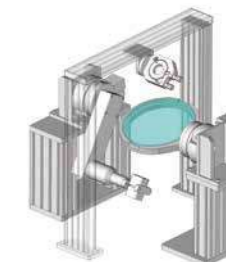
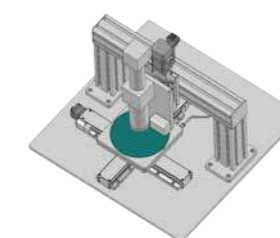
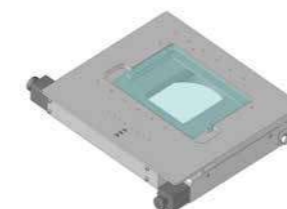
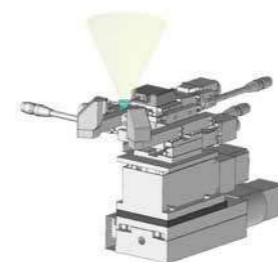

XY-axis custom

XYZ-axis custom

6-axis custom

High rigidity 6-axis custom



In addition to standard catalog products, we provide custom made stage products according to your requirement. Please feel free to contact us for details.

Sales area

- Japan
- United States of America
- China
- Korea
- Taiwan

Language

- English
- Japanese
- Chinese
- Korean

For more information

URL: <https://eng.surugaseiki.com/>

Contact: **SURUGA SEIKI CO.,LTD. SAN JOSE OFFICE**
2890 Zanker Road, Suite 204, San Jose, CA 95134, USA

[E-mail: e-ost@suruga-g.co.jp]
TEL: +1-408-931-6210

IoT Solution

A6 series + FP7, FP0R, FP-XH, FP0H

① Remote monitoring & control System by WebServer and E-Mail function

Solutions

- Remote monitoring not to go the site
- Quick check of machine abnormal condition
- Not sure when trouble occurs in any time
- Remote trouble shooting when trouble occurs after installation at factory
- To collect the data or change parameters when the person cannot touch or reach the machine directly
- Need a guide message for each predetermined period of time in order to judge the exchange timing

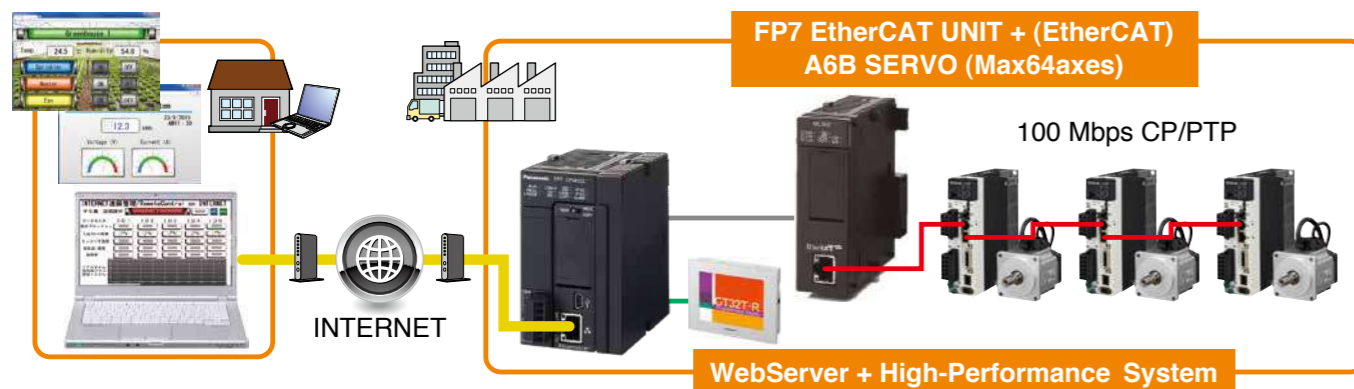

System Configuration

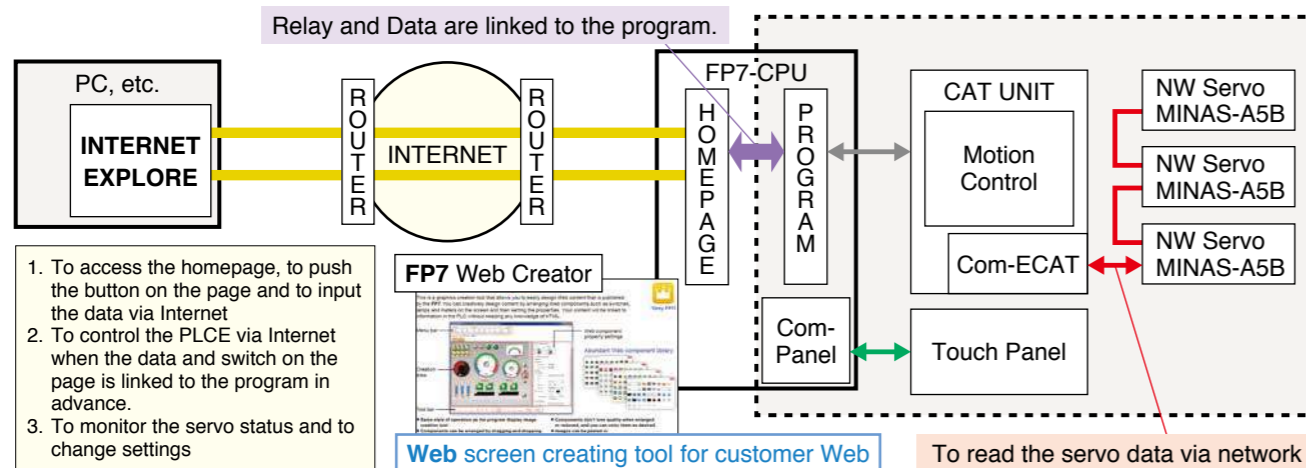

Another Proposals

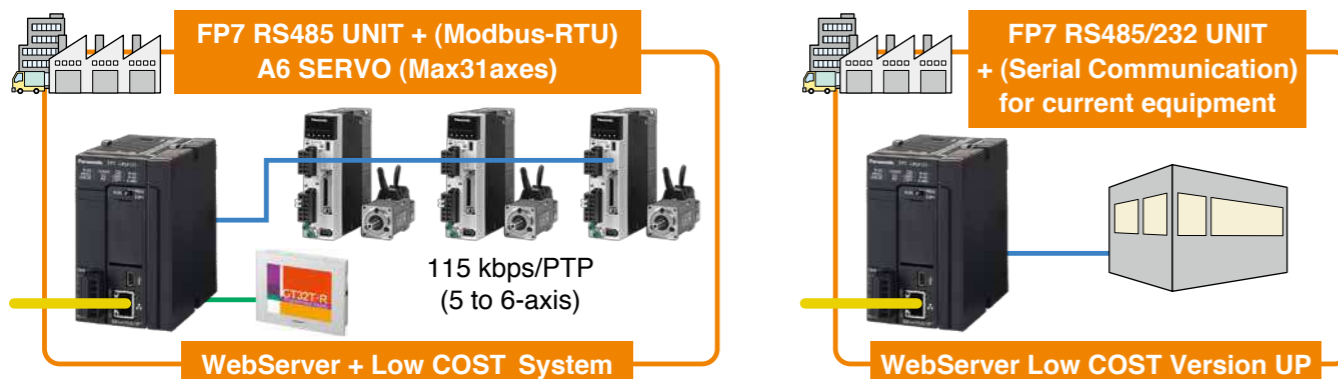

② Simple Smart Modbus SYSTEM: FP0R(RS485) + A6 SERVO

Solutions

- Less wiring
- To control a trouble by the data of load ratio and torque and so on
- To save the cost of positioning unit
- Improve the roughness of input pulse resolution due to the restriction of command pulse output frequency

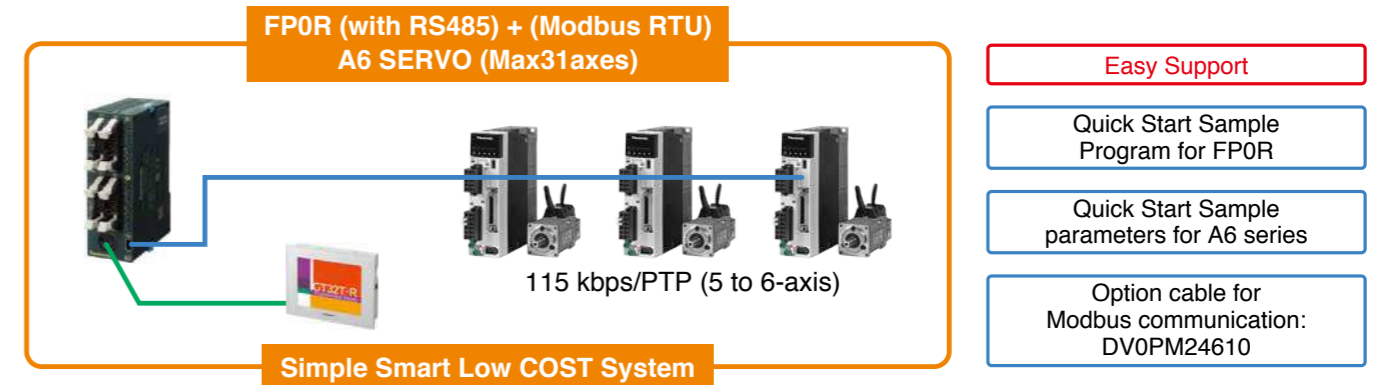

③ High-COST Performance SYSTEM: FPΣ + RTEX UNIT + A6N SERVO FP2SH + RTEX UNIT + A6N SERVO

Solutions

- To realize the reasonable high speed synchronized operation
- Less wiring
- To read a real time data of load ration and torque value
- To write and change the servo parameters

