

VRL-235 – 2-Stage Adapter Dimensions

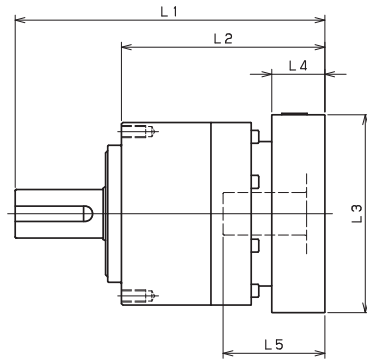

VRL

Model number	**: Adapter code	2-Stage					
		L1	L*	L2	L3	L4	L5
VRL-235-□-□-38** (Input shaft bore ≤ φ38)	HA	366.5	321.5	240.5	□130	45	82
	HB-HE	361.5	321.5	235.5	□130	40	77
	JA	366.5	321.5	240.5	□150	45	82
	KA-KB-KC	366.5	321.5	240.5	□180	45	82
	KD	401.5	321.5	275.5	□180	80	117
	KE	381.5	321.5	255.5	□180	60	97
	LA	366.5	321.5	240.5	□200	45	82
	LB	376.5	321.5	250.5	□200	55	92
	MA-MB	366.5	321.5	240.5	□220	45	82
	MC	381.5	321.5	255.5	□220	60	97
VRL-235-□-□-48** (Input shaft bore ≤ φ48)	MD	376.5	321.5	250.5	□220	55	92
	NA	366.5	321.5	240.5	□250	45	82
	KA	402.5	327.5	276.5	□180	75	118
	KB-KC	382.5	327.5	256.5	□180	55	98
	LA	382.5	327.5	256.5	□200	55	98
	MA	382.5	327.5	256.5	□220	55	98
VRL-235-□-□-65** (Input shaft bore ≤ φ65)	MB	402.5	327.5	276.5	□220	75	118
	NA	402.5	327.5	276.5	□250	75	118
	PA	402.5	327.5	276.5	□280	75	118
	MA-MB-MC-MD	--	--	--	--	--	--
	NA-NC	--	--	--	--	--	--
	NB-ND	--	--	--	--	--	--
PA	--	--	--	--	--	--	
PB	--	--	--	--	--	--	
QA-QB	--	--	--	--	--	--	

*1) Double reduction : 1/15~ 1/100

*2) Bushing will be inserted to adapt to motor shaft

For an explanation on the Adapter Flange Code, please turn to page 422.

A more comprehensive adapter flange offering can be found using the NIDEC-SHIMPO Online Selector Tool. The variety is constantly expanding and being updated on the Selector Tool. If you have any questions or need any support, contact NIDEC-SHIMPO.

VRL-SERIES

An excellent choice when very requiring good accuracy and reliability at an exceptional value. This inline planetary gearbox has a thread-in mounting style along with a level of precision and torque capacity that is best-in-class. Offered in a coaxial shaft design, with a maximum 5 arc-min backlash rating, the VRL is an accurate, high performance, cost effective solution for any OEM.

The VRL Series has dimensions that allow the reducer to be a direct substitute for some other common competitor models. The machining quality of the helical planetary gears means a very quiet and more efficient gearbox than competitive products. These planetary gearheads are the perfect solution for servomotor applications such as gantries, injection-molding machines, pick and place automation, and linear slides.

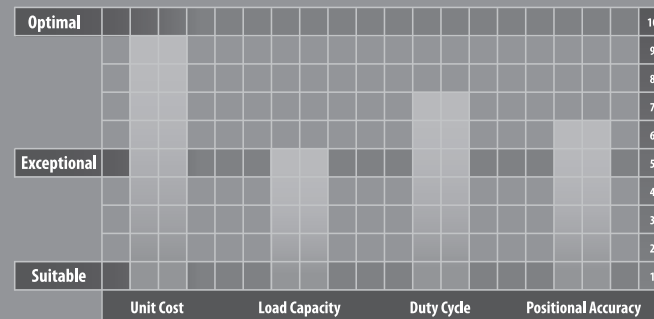



VRL-SERIES

- Industry standard mounting dimensions
- Large variety of frame sizes and ratios
- Thread-in mounting style
- Best-in-class backlash (≤ 5 arc-min)
- Ships in 48 hours in standard frame sizes
- Assembled in the USA

VRL-SERIES Inline shaft

VRL-235 – 1-Stage Adapter Dimensions

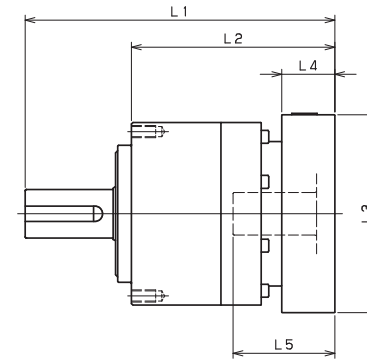

Model number	**: Adapter code	1-Stage					
		L1	L*	L2	L3	L4	L5
VRL-235-□-□-38** (Input shaft bore $\leq \varnothing 38$)	HA	--	--	--	--	--	--
	HB-HE	--	--	--	--	--	--
	JA	--	--	--	--	--	--
	KA-KB-KC	--	--	--	--	--	--
	KD	--	--	--	--	--	--
	KE	--	--	--	--	--	--
	LA	--	--	--	--	--	--
	LB	--	--	--	--	--	--
	MA-MB	--	--	--	--	--	--
	MC	--	--	--	--	--	--
VRL-235-□-□-48** (Input shaft bore $\leq \varnothing 48$)	KA	367.5	292.5	241.5	$\square 180$	75	118
	KB-KC	347.5	292.5	221.5	$\square 180$	55	98
	LA	347.5	292.5	221.5	$\square 200$	55	98
	MA	347.5	292.5	221.5	$\square 220$	55	98
	MB	367.5	292.5	241.5	$\square 220$	75	118
	NA	367.5	292.5	241.5	$\square 250$	75	118
	PA	367.5	292.5	241.5	$\square 280$	75	118
VRL-235-□-□-65** (Input shaft bore $\leq \varnothing 65$)	MA-MB-MC-MD	371.5	291.5	245.5	$\square 220$	80	122
	NA-NC	371.5	291.5	245.5	$\square 250$	80	122
	NB-ND	401.5	291.5	275.5	$\square 250$	110	152
	PA	391.5	291.5	265.5	$\square 280$	100	142
	PB	401.5	291.5	275.5	$\square 280$	110	152
	QA-QB	391.5	291.5	265.5	$\square 320$	100	142

*1) Single reduction : 1/3~ 1/10

*2) Bushing will be inserted to adapt to motor shaft

For an explanation on the Adapter Flange Code, please turn to page 422.

A more comprehensive adapter flange offering can be found using the NIDEC-SHIMPO Online Selector Tool. The variety is constantly expanding and being updated on the Selector Tool. If you have any questions or need any support, contact NIDEC-SHIMPO.

VRL-235 - 2-Stage Dimensions

Input shaft bore $\leq \varnothing 38$

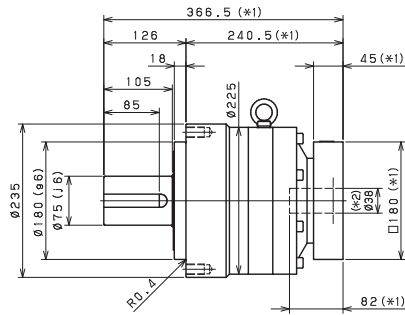
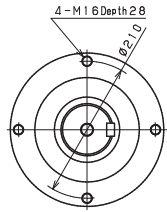

Input shaft bore $\leq \varnothing 48$

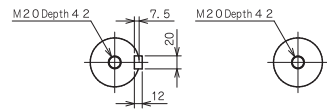
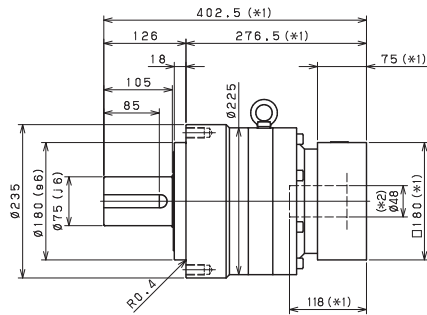
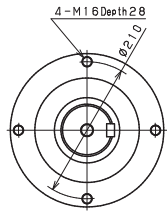

Shaft with key

Smooth shaft

*1) Length will vary depending on motor
 *2) Bushing will be inserted to adapt to motor shaft

VRL

VRL-Series- Features

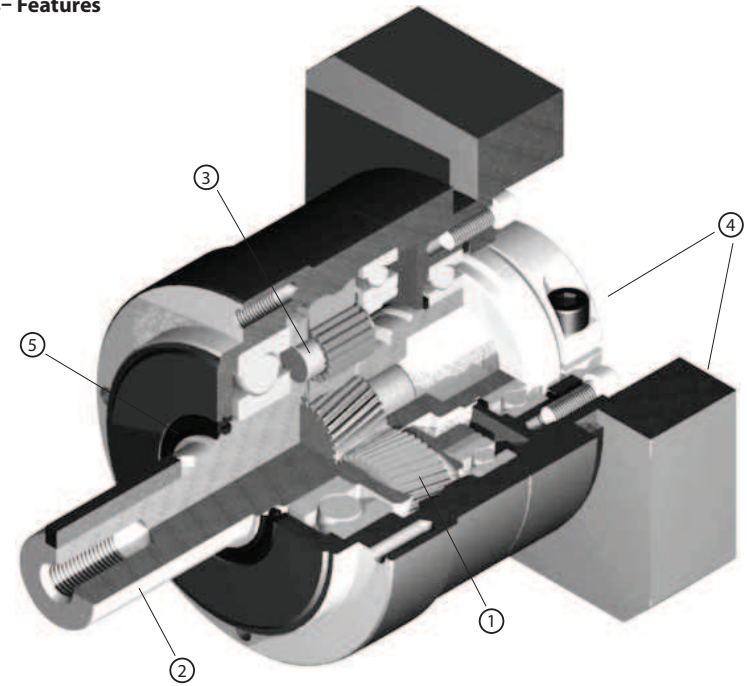

- ① Quiet operation: Helical cut gears contribute to reduced vibration and noise
- ② High precision: Standard backlash is 5 arc-min, ideal for the most accurate applications
- ③ High rigidity & torque: Rigidity and torque capacity are achieved by using uncaged needle roller bearings
- ④ Adapter bushing connection: Enables a simple, effective attachment to most servo motors
- ⑤ No leakage through the seal: High viscosity, anti-separation grease does not liquefy and does not migrate away from the gears
- ⑥ Maintenance-free: No need to replace the grease for the life of the unit. The reducer can be positioned in any orientation

VRL-235 – 2-Stage Specifications

Frame Size	235										
Stage	2-Stage										
Ratio	Unit	Note	45	50	60	70	80	90	100		
Nominal Output Torque	[Nm]	*1	1000	1500	1500	1500	1500	1000	1000		
Maximum Acceleration Torque	[Nm]	*2	1300	2300	2300	2300	1800	1300	1200		
Emergency Stop Torque	[Nm]	*3	4000	5000	5000	5000	5000	4000	4000		
Nominal Input Speed	[rpm]	*4	1000								
Maximum Input Speed	[rpm]	*5	2000								
No Load Running Torque	[Nm]	*6	1.14								
Permitted Radial Load	[N]	*7	14000	15000	15000	15000	15000	15000	15000		
Permitted Axial Load	[N]	*8	14000	14000	14000	14000	14000	14000	14000		
Maximum Radial Load	[N]	*9	15000								
Maximum Axial Load	[N]	*10	14000								
Moment of Inertia (≤ Ø 38)	[kgcm ²]	--	13.000	12.000	12.000	12.000	12.000	12.000	12.000		
Moment of Inertia (≤ Ø 48)	[kgcm ²]	--	35.000	33.000	33.000	33.000	33.000	33.000	33.000		
Moment of Inertia (≤ Ø 65)	[kgcm ²]	--	--	--	--	--	--	--	--		
Efficiency	[%]	*11	92								
Torsional Rigidity	[Nm/arc-min]	*12	400								
Maximum Torsional Backlash	[arc-min]	--	≤ 5								
Noise Level	[dB]	*13	61								
Protection Class	--	*14	IP54 (IP65)								
Ambient Temperature	[°C]	--	0-40								
Permitted Housing Temperature	[°C]	--	90								
Weight	[kg]	*15	57								

- *1) At nominal input speed, service life is 20,000 hours
- *2) The maximum torque when starting or stopping operation
- *3) The maximum torque allowed under a stress situation (Permitted 1,000 times during service life)
- *4) The average input speed
- *5) The maximum intermittent input speed
- *6) This is the torque at no load applied on the input shaft. The input speed is 1,000 rpm for VRL235
- *7) At this load and nominal input speed, service life will be 20,000 hours. (The radial load applied to the output side bearing)
- *8) At this load and nominal input speed, service life will be 20,000 hours. (The axial load applied to the output shaft center)
- *9) The maximum radial load that the reducer can accept
- *10) The maximum axial load that the reducer can accept
- *11) The efficiency at the nominal torque rating
- *12) This does not include the lost motion
- *13) Contact NIDEC-SHIMPO for the testing conditions and environment
- *14) IP65 (wash-down) is available as an option. Contact NIDEC-SHIMPO for more details and our food grade options
- *15) The weight may vary slightly between models

ABLE Washdown and Food Duty Reducers

Motion control applications for production environments within the Food and Beverage, Personal Care, and Pharmaceutical industries often require materials of construction and sealants that provide higher levels of protection. To improve our product offering to these customers, NIDEC-SHIMPO is now offering Washdown and Food Grade à la carte options for our inline and right-angle planetary reducers. These options provide ultimate flexibility without sacrificing on precision and performance.

Upgradeable Features include the following;

- Special coatings, including Food Grade white epoxy, Steel-It, among others
- Sealed bearing, and Viton seal at output
- Stainless steel screws, fasteners, etc.
- Special sealant for better resistance to solvents
- Stainless steel output shaft
- Food Grade grease for exposure sensitive environments

Note:

- 1) For Food Grade grease, special consideration is required when sizing the reducer. Contact NIDEC-SHIMPO for support on these applications.
- 2) IP65 rating is based on standard protection criteria and commonly accepted test conditions. Any exposure at extreme conditions (continuous exposure, excessive pressure, etc.) is not considered accepted environment for given IP rating.

Build your Ideal Reducer

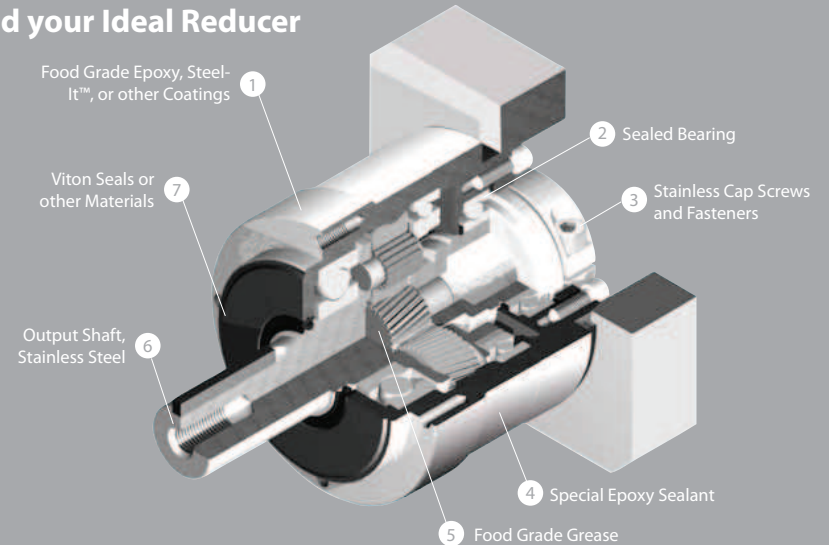

Immediate Availability for these Models:

Series	VRL		
Frame Size	070	090	120
1-Stage	3, 5, 7, 10:1		
2-Stage	15, 25, 28, 30, 35, 50, 70, 100:1		

Series	VRB	
Frame Size	060	115
1-Stage	3, 5, 7, 10:1	
2-Stage	15, 25, 28, 30, 35, 50, 70, 100:1	

VRL and VRB inline frame sizes and ratios can be quickly assembled with the Washdown and Food Grade options. Small quantity orders will be tested, assembled, and shipped within 2 – 4 days. For all other VRL, VRB, VRS inline series and EVL, EVB, EVS right-angle series frame size and ratio combinations, please contact SHIMPO for price and availability from our main manufacturing facility.

Featured Series Product Extension

VRL-SERIES Inline shaft

There are many Washdown and Food Grade features that can be added to your reducer. Below is an explanation on the model code, when specifying a reducer with the ideal performance and protection for your application.

Washdown – Model Code

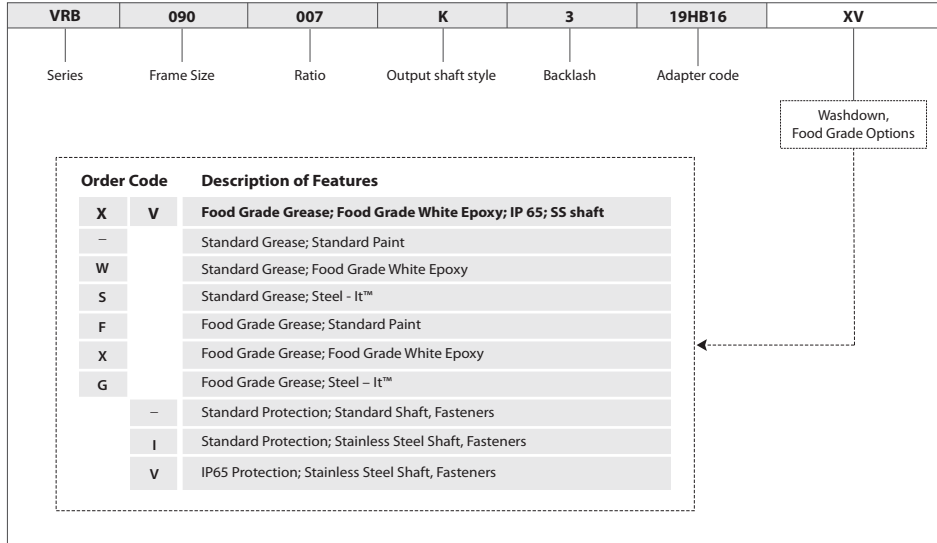

As the global marketplace becomes increasingly competitive, NIDEC-SHIMPO continues to raise the bar in terms of product quality, flexibility, and availability – providing a real value to our customers. Our new Washdown and Food duty reducers serve as another good example where NIDEC-SHIMPO is delivering improved value to our customers.

Contact NIDEC-SHIMPO for more details:

Toll-free: (800) 842-1470

Email: info@nidec-shimpo.com

Featured Series Product Extension

VRL-235 – 1-Stage Specifications

Frame Size		235									
Stage		1-Stage									
Ratio	Unit	Note	3	4	5	6	7	8	9	10	
Nominal Output Torque	[Nm]	*1	1000	1500	1500	1500	1500	1500	1000	1000	
Maximum Acceleration Torque	[Nm]	*2	1600	2300	2300	2300	2300	2200	1900	1600	
Emergency Stop Torque	[Nm]	*3	4000	5000	5000	5000	5000	5000	4000	4000	
Nominal Input Speed	[rpm]	*4	1000								
Maximum Input Speed	[rpm]	*5	2000								
No Load Running Torque	[Nm]	*6	2.92								
Permitted Radial Load	[N]	*7	5800	6400	6900	7300	7700	8000	8400	8700	
Permitted Axial Load	[N]	*8	6400	7200	7900	8600	9200	9700	10000	11000	
Maximum Radial Load	[N]	*9	15000								
Maximum Axial Load	[N]	*10	14000								
Moment of Inertia (≤ Ø 38)	[kgcm ²]	--	--	--	--	--	--	--	--	--	
Moment of Inertia (≤ Ø 48)	[kgcm ²]	--	90.000	62.000	52.000	47.000	42.000	40.000	39.000	38.000	
Moment of Inertia (≤ Ø 65)	[kgcm ²]	--	150.000	120.000	110.000	110.000	100.000	100.000	99.000	98.000	
Efficiency	[%]	*11	97								
Torsional Rigidity	[Nm/arc-min]	*12	400								
Maximum Torsional Backlash	[arc-min]	--	≤ 5								
Noise Level	[dB]	*13	61								
Protection Class	--	*14	IP54 (IP65)								
Ambient Temperature	[°C]	--	0-40								
Permitted Housing Temperature	[°C]	--	90								
Weight	[kg]	*15	55								

VRL-235 – 2-Stage Specifications

Frame Size		235									
Stage		2-Stage									
Ratio	Unit	Note	15	16	20	25	28	30	35	40	
Nominal Output Torque	[Nm]	*1	1000	1500	1500	1500	1500	1000	1500	1500	
Maximum Acceleration Torque	[Nm]	*2	1600	2300	2300	2300	2300	1600	2300	2300	
Emergency Stop Torque	[Nm]	*3	4000	5000	5000	5000	5000	4000	5000	5000	
Nominal Input Speed	[rpm]	*4	1000								
Maximum Input Speed	[rpm]	*5	2000								
No Load Running Torque	[Nm]	*6	1.14								
Permitted Radial Load	[N]	*7	9900	10000	11000	12000	12000	13000	13000	14000	
Permitted Axial Load	[N]	*8	13000	13000	14000	14000	14000	14000	14000	14000	
Maximum Radial Load	[N]	*9	15000								
Maximum Axial Load	[N]	*10	14000								
Moment of Inertia (≤ Ø 38)	[kgcm ²]	--	14.000	16.000	14.000	14.000	15.000	12.000	13.000	12.000	
Moment of Inertia (≤ Ø 48)	[kgcm ²]	--	36.000	37.000	35.000	35.000	36.000	34.000	35.000	33.000	
Moment of Inertia (≤ Ø 65)	[kgcm ²]	--	--	--	--	--	--	--	--	--	
Efficiency	[%]	*11	92								
Torsional Rigidity	[Nm/arc-min]	*12	400								
Maximum Torsional Backlash	[arc-min]	--	≤ 5								
Noise Level	[dB]	*13	61								
Protection Class	--	*14	IP54 (IP65)								
Ambient Temperature	[°C]	--	0-40								
Permitted Housing Temperature	[°C]	--	90								
Weight	[kg]	*15	57								

VRL-205 – 2-Stage Adapter Dimensions

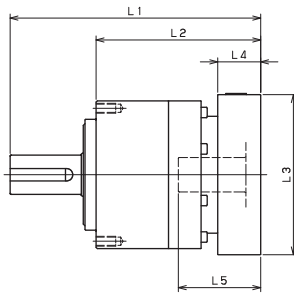

VRL

Model number	**: Adapter code	2-Stage					
		L1	L*	L2	L3	L4	L5
VRL-205-□-□-28** (Input shaft bore ≤ φ28)	FA-FB-FC	316	281	216	□100	35	67
	GA-GB-GC-GD-GE-GF-GG-GH	316	281	216	□115	35	67
	HA-HC-HD	316	281	216	□130	35	67
	HB	326	281	226	□130	45	77
	HF	311	281	211	□130	30	62
	JA-JB-JC-JF	316	281	216	□150	35	67
	KA-KB-KE	316	281	216	□180	35	67
	LA	316	281	216	□200	35	67
	LB	326	281	226	□200	45	77
	MA	316	281	216	□220	35	67
	MB	326	281	226	□220	45	77
	HA	331	286	231	□130	45	82
	HB-HE	326	286	226	□130	40	77
	JA	331	286	231	□150	45	82
VRL-205-□-□-38** (Input shaft bore ≤ φ38)	KA-KB-KC	331	286	231	□180	45	82
	KD	366	286	266	□180	80	117
	KE	346	286	246	□180	60	97
	LB	341	286	241	□200	55	92
	MA-MB	331	286	231	□220	45	82
	MC	346	286	246	□220	60	97
	MD	341	286	241	□220	55	92
	NA	331	286	231	□250	45	82
	KA	367	292	267	□180	75	118
	KB-KC	347	292	247	□180	55	98
VRL-205-□-□-48** (Input shaft bore ≤ φ48)	LA	347	292	247	□200	55	98
	MA	347	292	247	□220	55	98
	MB	367	292	267	□220	75	118
	NA	367	292	267	□250	75	118
	PA	367	292	267	□280	75	118
	MA-MB-MC-MD	--	--	--	--	--	--
VRL-205-□-□-65** (Input shaft bore ≤ φ65)	NA-NC	--	--	--	--	--	--
	NB-ND	--	--	--	--	--	--
	PA	--	--	--	--	--	--
	PB	--	--	--	--	--	--

*1) Double reduction : 1/15~ 1/100 *2) Bushing will be inserted to adapt to motor shaft

For an explanation on the Adapter Flange Code, please turn to page 422.

A more comprehensive adapter flange offering can be found using the NIDEC-SHIMPO Online Selector Tool. The variety is constantly expanding and being updated on the Selector Tool. If you have any questions or need any support, contact NIDEC-SHIMPO.

VRL-050 – 1-Stage Specifications

Frame Size	050									
Stage	1-Stage									
Ratio	Units	Note	3	4	5	6	7	8	9	10
Nominal Output Torque	[Nm]	*1	6	9	9	9	9	9	6	6
Maximum Acceleration Torque	[Nm]	*2	12	18	18	18	18	18	12	12
Emergency Stop Torque	[Nm]	*3	30	35	35	35	35	35	30	30
Nominal Input Speed	[rpm]	*4	4000							
Maximum Input Speed	[rpm]	*5	8000							
No Load Running Torque	[Nm]	*6	0.03							
Permitted Radial Load	[N]	*7	240	270	290	310	320	340	350	360
Permitted Axial Load	[N]	*8	270	300	330	360	380	410	430	450
Maximum Radial Load	[N]	*9	710							
Maximum Axial Load	[N]	*10	640							
Moment of Inertia (≤Ø 8)	[kgcm ²]	--	0.053	0.041	0.036	0.034	0.032	0.031	0.031	0.030
Moment of Inertia (≤ Ø 14)	[kgcm ²]	--	0.091	0.079	0.074	0.072	0.071	0.070	0.069	0.069
Efficiency	[%]	*11	95							
Torsional Rigidity	[Nm/arc-min]	*12	2							
Maximum Torsional Backlash	[arc-min]	--	≤ 5							
Noise Level	[dB]	*13	61							
Protection Class	--	*14	IP54 (IP65)							
Ambient Temperature	[°C]	--	0-40							
Permitted Housing Temperature	[°C]	--	90							
Weight	[kg]	*15	0.7							

VRL-050 – 2-Stage Specifications

Frame Size	050									
Stage	2-Stage									
Ratio	Units	Note	15	16	20	25	28	30	35	40
Nominal Output Torque	[Nm]	*1	6	9	9	9	9	9	9	9
Maximum Acceleration Torque	[Nm]	*2	12	18	18	18	18	18	18	18
Emergency Stop Torque	[Nm]	*3	30	35	35	35	35	35	35	35
Nominal Input Speed	[rpm]	*4	4000							
Maximum Input Speed	[rpm]	*5	8000							
No Load Running Torque	[Nm]	*6	0.01							
Permitted Radial Load	[N]	*7	410	420	460	490	510	520	550	570
Permitted Axial Load	[N]	*8	540	550	610	640	640	640	640	640
Maximum Radial Load	[N]	*9	710							
Maximum Axial Load	[N]	*10	640							
Moment of Inertia (≤Ø 8)	[kgcm ²]	--	0.035	0.038	0.034	0.034	0.038	0.030	0.034	0.030
Moment of Inertia (≤ Ø 14)	[kgcm ²]	--	--	--	--	--	--	--	--	--
Efficiency	[%]	*11	90							
Torsional Rigidity	[Nm/arc-min]	*12	2							
Maximum Torsional Backlash	[arc-min]	--	≤ 7							
Noise Level	[dB]	*13	61							
Protection Class	--	*14	IP54 (IP65)							
Ambient Temperature	[°C]	--	0-40							
Permitted Housing Temperature	[°C]	--	90							
Weight	[kg]	*15	0.8							

VRL-050 – 2-Stage Specifications

Frame Size	050										
Stage	2-Stage										
Ratio	Units	Note	45	50	60	70	80	90	100		
Nominal Output Torque	[Nm]	*1	6	9	9	9	9	6	6		
Maximum Acceleration Torque	[Nm]	*2	12	18	18	18	18	12	12		
Emergency Stop Torque	[Nm]	*3	30	35	35	35	35	30	30		
Nominal Input Speed	[rpm]	*4	4000								
Maximum Input Speed	[rpm]	*5	8000								
No Load Running Torque	[Nm]	*6	0.01								
Permitted Radial Load	[N]	*7	600	620	660	690	710	710	710		
Permitted Axial Load	[N]	*8	640	640	640	640	640	640	640		
Maximum Radial Load	[N]	*9	710								
Maximum Axial Load	[N]	*10	640								
Moment of Inertia ($\leq \varnothing 8$)	[kgcm ²]	--	0.034	0.030	0.030	0.030	0.030	0.030	0.030		
Moment of Inertia ($\leq \varnothing 14$)	[kgcm ²]	--	--	--	--	--	--	--	--		
Efficiency	[%]	*11	90								
Torsional Rigidity	[Nm/arc-min]	*12	2								
Maximum Torsional Backlash	[arc-min]	--	≤ 7								
Noise Level	[dB]	*13	61								
Protection Class	--	*14	IP54 (IP65)								
Ambient Temperature	[°C]	--	0-40								
Permitted Housing Temperature	[°C]	--	90								
Weight	[kg]	*15	0.8								

- *1) At nominal input speed, service life is 20,000 hours
- *2) The maximum torque when starting or stopping operation
- *3) The maximum torque allowed under a stress situation (Permitted 1,000 times during service life)
- *4) The average input speed
- *5) The maximum intermittent input speed
- *6) This is the torque at no load applied on the input shaft. The input speed is 4,000 rpm for VRL 050
- *7) At this load and nominal input speed, service life will be 20,000 hours. (The radial load applied to the output side bearing)
- *8) At this load and nominal input speed, service life will be 20,000 hours. (The axial load applied to the output shaft center)
- *9) The maximum radial load that the reducer can accept
- *10) The maximum axial load that the reducer can accept
- *11) The efficiency at the nominal torque rating
- *12) This does not include the lost motion
- *13) Contact NIDEC-SHIMPO for the testing conditions and environment
- *14) IP65 (wash-down) is available as an option. Contact NIDEC-SHIMPO for more details and our food grade options
- *15) The weight may vary slightly between models

VRL

VRL-205 – 1-Stage Adapter Dimensions

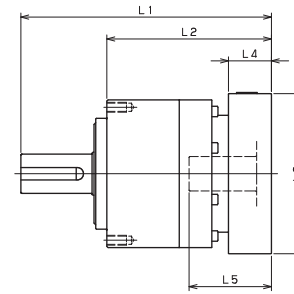

Model number	**: Adapter code	1-Stage					
		L1	L*	L2	L3	L4	L5
VRL-205-□-□-28** (Input shaft bore $\leq \varnothing 28$)	FA+FB+FC	--	--	--	--	--	--
	GA+GB+GC+GD+GE+GF+GG+GH	--	--	--	--	--	--
	HA+HC+HD	--	--	--	--	--	--
	HB	--	--	--	--	--	--
	HF	--	--	--	--	--	--
	JA+JB+JC+JF	--	--	--	--	--	--
	KA+KB+KE	--	--	--	--	--	--
	LA	--	--	--	--	--	--
	LB	--	--	--	--	--	--
	MA	--	--	--	--	--	--
VRL-205-□-□-38** (Input shaft bore $\leq \varnothing 38$)	HA	286.5	241.5	186.5	□130	45	82
	HB+HE	281.5	241.5	181.5	□130	40	77
	JA	286.5	241.5	186.5	□150	45	82
	KA+KB+KC	286.5	241.5	186.5	□180	45	82
	KD	321.5	241.5	221.5	□180	80	117
	KE	301.5	241.5	201.5	□180	60	97
	LB	296.5	241.5	196.5	□200	55	92
	MA+MB	286.5	241.5	186.5	□220	45	82
	MC	301.5	241.5	201.5	□220	60	97
	MD	296.5	241.5	196.5	□220	55	92
VRL-205-□-□-48** (Input shaft bore $\leq \varnothing 48$)	NA	286.5	241.5	186.5	□250	45	82
	KA	322.5	247.5	222.5	□180	75	118
	KB+KC	302.5	247.5	202.5	□180	55	98
	LA	302.5	247.5	202.5	□200	55	98
	MA	302.5	247.5	202.5	□220	55	98
	MB	322.5	247.5	222.5	□220	75	118
	NA	322.5	247.5	222.5	□250	75	118
VRL-205-□-□-65** (Input shaft bore $\leq \varnothing 65$)	PA	322.5	247.5	222.5	□280	75	118
	MA+MB+MC+MD	334	254	234	□220	80	122
	NA+NC	334	254	234	□250	80	122
	NB+ND	364	254	264	□250	110	152
	PA	354	254	254	□280	100	142
	PB	364	254	264	□280	110	152

*1) Single reduction : 1/3~ 1/10 *2) Bushing will be inserted to adapt to motor shaft

For an explanation on the Adapter Flange Code, please turn to page 422.

A more comprehensive adapter flange offering can be found using the NIDEC-SHIMPO Online Selector Tool. The variety is constantly expanding and being updated on the Selector Tool. If you have any questions or need any support, contact NIDEC-SHIMPO.

VRL-205 - 2-Stage Dimensions

Input shaft bore $\leq \varnothing 28$

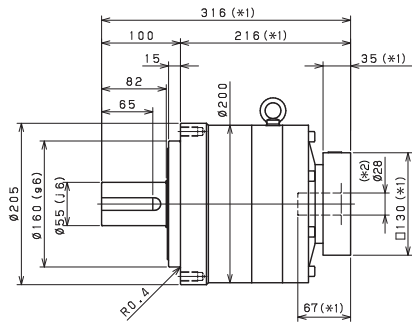
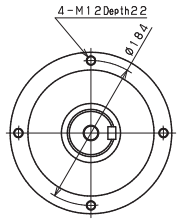

Input shaft bore $\leq \varnothing 38$

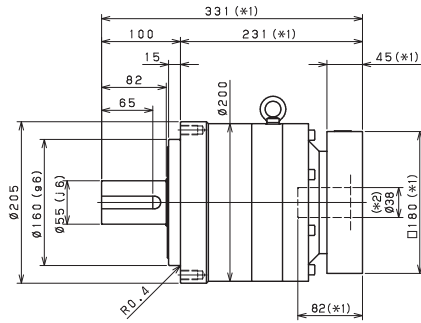
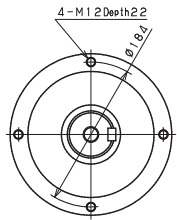

Input shaft bore $\leq \varnothing 48$

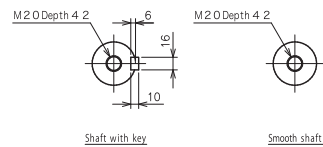
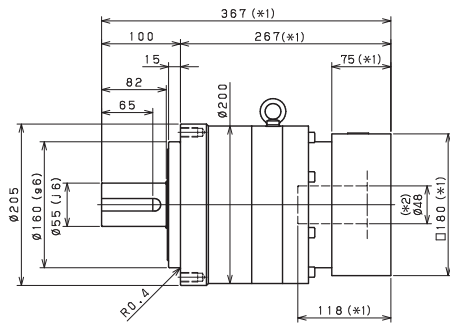
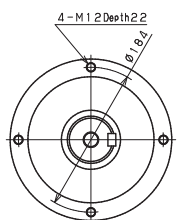

*1) Length will vary depending on motor
*2) Bushing will be inserted to adapt to motor shaft

VRL

VRL-050 - 1-Stage Dimensions

Input shaft bore $\leq \varnothing 8$

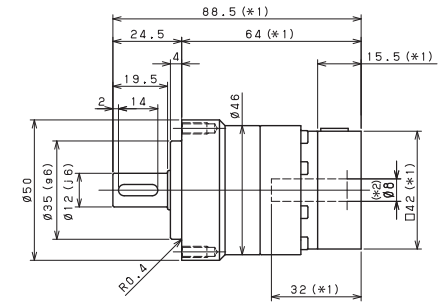
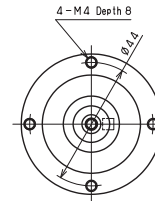

Input shaft bore $\leq \varnothing 14$

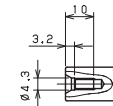
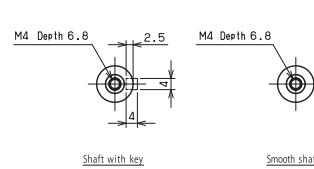
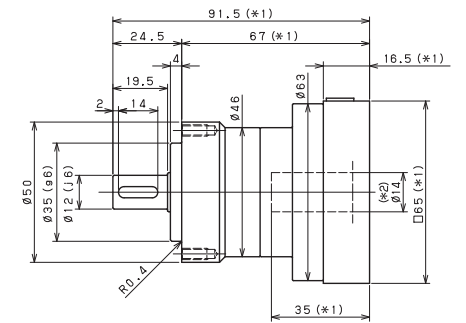
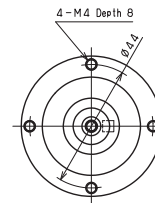

*1) Length will vary depending on motor
*2) Bushing will be inserted to adapt to motor shaft

VRL-050 – 2-Stage Dimensions

Input shaft bore $\leq \phi 8$

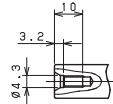
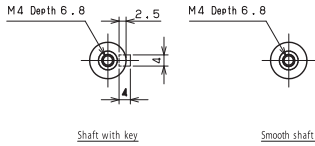
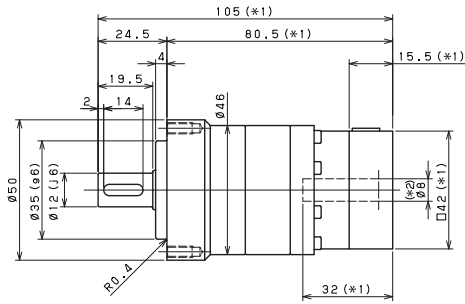
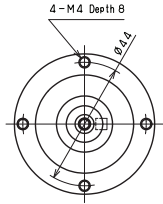

- *1) Length will vary depending on motor
- *2) Bushing will be inserted to adapt to motor shaft

VRL

VRL-205 – 1-Stage Dimensions

Input shaft bore $\leq \phi 38$

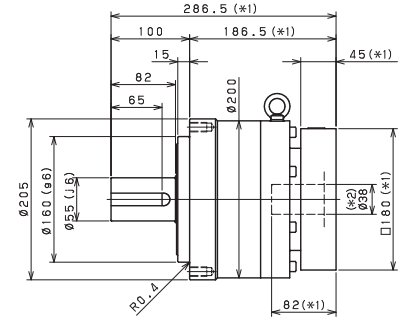
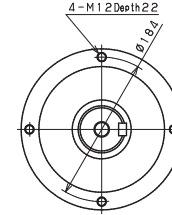

Input shaft bore $\leq \phi 48$

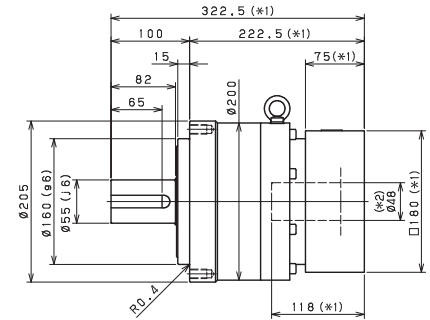
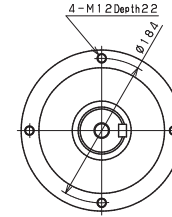

Input shaft bore $\leq \phi 65$

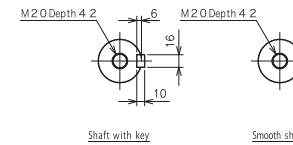
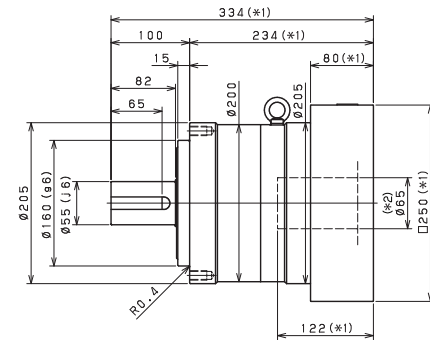
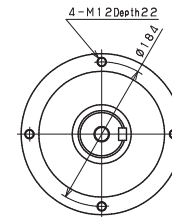

- *1) Length will vary depending on motor
- *2) Bushing will be inserted to adapt to motor shaft

VRL-205 – 2-Stage Specifications

Frame Size	205									
Stage	2-Stage									
Ratio	Unit	Note	45	50	60	70	80	90	100	
Nominal Output Torque	[Nm]	*1	500	750	750	750	750	500	500	
Maximum Acceleration Torque	[Nm]	*2	970	1400	1400	1400	1400	970	970	
Emergency Stop Torque	[Nm]	*3	2200	2750	2750	2750	2750	2200	2200	
Nominal Input Speed	[rpm]	*4	1500							
Maximum Input Speed	[rpm]	*5	3000							
No Load Running Torque	[Nm]	*6	1.39							
Permitted Radial Load	[N]	*7	14000	14000	15000	15000	15000	15000	15000	
Permitted Axial Load	[N]	*8	14000	14000	14000	14000	14000	14000	14000	
Maximum Radial Load	[N]	*9	15000							
Maximum Axial Load	[N]	*10	14000							
Moment of Inertia (≤Ø 28)	[kgcm ²]	--	4.000	3.100	3.100	3.100	3.100	3.100	3.100	
Moment of Inertia (≤ Ø 38)	[kgcm ²]	--	12.000	11.000	11.000	11.000	11.000	11.000	11.000	
Moment of Inertia (≤ Ø 48)	[kgcm ²]	--	34.000	33.000	33.000	33.000	33.000	33.000	33.000	
Moment of Inertia (≤ Ø 65)	[kgcm ²]	--	--	--	--	--	--	--	--	
Efficiency	[%]	*11	90							
Torsional Rigidity	[Nm/arc-min]	*12	175							
Maximum Torsional Backlash	[arc-min]	--	≤ 5							
Noise Level	[dB]	*13	67							
Protection Class	--	*14	IP54 (IP65)							
Ambient Temperature	[°C]	--	0-40							
Permitted Housing Temperature	[°C]	--	90							
Weight	[kg]	*15	40							

- *1) At nominal input speed, service life is 20,000 hours
- *2) The maximum torque when starting or stopping operation
- *3) The maximum torque allowed under a stress situation (Permitted 1,000 times during service life)
- *4) The average input speed
- *5) The maximum intermittent input speed
- *6) This is the torque at no load applied on the input shaft. The input speed is 1,500 rpm for VRL205
- *7) At this load and nominal input speed, service life will be 20,000 hours. (The radial load applied to the output side bearing)
- *8) At this load and nominal input speed, service life will be 20,000 hours. (The axial load applied to the output shaft center)
- *9) The maximum radial load that the reducer can accept
- *10) The maximum axial load that the reducer can accept
- *11) The efficiency at the nominal torque rating
- *12) This does not include the lost motion
- *13) Contact NIDEC-SHIMPO for the testing conditions and environment
- *14) IP65 (wash-down) is available as an option. Contact NIDEC-SHIMPO for more details and our food grade options
- *15) The weight may vary slightly between models

VRL

VRL-050 – 1-Stage Adapter Dimensions

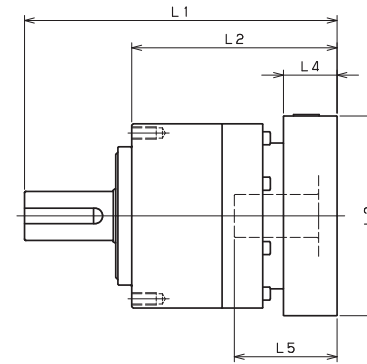

Model number	**: Adapter code	1-Stage					
		L1	L*	L2	L3	L4	L5
VRL-050-□-□-58** (Input shaft bore ≤ φ8)	ZA-ZC-ZD-ZF-ZG-ZL-ZM-ZN-ZQ	88.5	73	64	□42	15.5	32
	ZB-ZE-ZH-ZJ-ZK	93.5	73	69	□42	20.5	37
	BA-BB-BD-BE-BG-BH-BJ	88.5	73	64	□60	15.5	32
	BC-BF	93.5	73	69	□60	20.5	37
VRL-050-□-□-14** (Input shaft bore ≤ φ14)	BA-BB-BD-BE-BF-BG-BJ-BK-BP	91.5	75	67	□65	16.5	35
	BC-BH-BM-BN	96.5	75	72	□65	21.5	40
	BL	101.5	75	77	□65	26.5	45

- *1) Single reduction : 1/3 - 1/10
- *2) Bushing will be inserted to adapt to motor shaft

For an explanation on the Adapter Flange Code, please turn to page 422.

A more comprehensive adapter flange offering can be found using the NIDEC-SHIMPO Online Selector Tool. The variety is constantly expanding and being updated on the Selector Tool. If you have any questions or need any support, contact NIDEC-SHIMPO.

VRL-050 – 2-Stage Adapter Dimensions

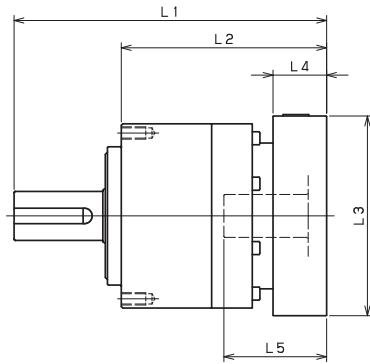

VRL

Model number	**: Adapter code	2-Stage					
		L1	L*	L2	L3	L4	L5
VRL-050-□-□-58** (Input shaft bore ≤ φ8)	ZA-ZC-ZD-ZF-ZG-ZL-ZM-ZN-ZQ	105	89.5	80.5	□42	15.5	32
	ZB-ZE-ZH-ZJ-ZK	110	89.5	85.5	□42	20.5	37
	BA-BB-BD-BE-BG-BH-BJ	105	89.5	80.5	□60	15.5	32
	BC-BF	110	89.5	85.5	□60	20.5	37
VRL-050-□-□-14** (Input shaft bore ≤ φ14)	BA-BB-BD-BE-BF-BG-BJ-BK-BP	--	--	--	--	--	--
	BC-BH-BM-BN	--	--	--	--	--	--
	BL	--	--	--	--	--	--

*1) Double reduction : 1/15 - 1/100

*2) Bushing will be inserted to adapt to motor shaft

For an explanation on the Adapter Flange Code, please turn to page 422.

A more comprehensive adapter flange offering can be found using the NIDEC-SHIMPO Online Selector Tool. The variety is constantly expanding and being updated on the Selector Tool. If you have any questions or need any support, contact NIDEC-SHIMPO.

VRL-205 – 1-Stage Specifications

Frame Size		205									
Stage		1-Stage									
Ratio	Unit	Note	3	4	5	6	7	8	9	10	
Nominal Output Torque	[Nm]	*1	500	750	750	750	750	750	500	500	
Maximum Acceleration Torque	[Nm]	*2	970	1400	1400	1400	1400	1400	970	970	
Emergency Stop Torque	[Nm]	*3	2200	2750	2750	2750	2750	2750	2200	2200	
Nominal Input Speed	[rpm]	*4	1500								
Maximum Input Speed	[rpm]	*5	3000								
No Load Running Torque	[Nm]	*6	2.68								
Permitted Radial Load	[N]	*7	5600	6200	6700	7100	7400	7800	8100	8400	
Permitted Axial Load	[N]	*8	4300	4900	5400	5800	6300	6600	7000	7300	
Maximum Radial Load	[N]	*9	15000								
Maximum Axial Load	[N]	*10	14000								
Moment of Inertia (≤ Ø 28)	[kgcm ²]	--	--	--	--	--	--	--	--	--	
Moment of Inertia (≤ Ø 38)	[kgcm ²]	--	44.000	28.000	22.000	18.000	16.000	15.000	14.000	14.000	
Moment of Inertia (≤ Ø 48)	[kgcm ²]	--	66.000	50.000	44.000	41.000	38.000	37.000	36.000	36.000	
Moment of Inertia (≤ Ø 65)	[kgcm ²]	--	130.000	110.000	100.000	100.000	99.000	97.000	97.000	96.000	
Efficiency	[%]	*11	95								
Torsional Rigidity	[Nm/arc-min]	*12	175								
Maximum Torsional Backlash	[arc-min]	--	≤ 5								
Noise Level	[dB]	*13	67								
Protection Class	--	*14	IP54 (IP65)								
Ambient Temperature	[°C]	--	0-40								
Permitted Housing Temperature	[°C]	--	90								
Weight	[kg]	*15	39								

VRL-205 – 2-Stage Specifications

Frame Size		205									
Stage		2-Stage									
Ratio	Unit	Note	15	16	20	25	28	30	35	40	
Nominal Output Torque	[Nm]	*1	500	750	750	750	750	500	750	750	
Maximum Acceleration Torque	[Nm]	*2	970	1400	1400	1400	1400	1400	970	1400	
Emergency Stop Torque	[Nm]	*3	2200	2750	2750	2750	2750	2200	2750	2750	
Nominal Input Speed	[rpm]	*4	1500								
Maximum Input Speed	[rpm]	*5	3000								
No Load Running Torque	[Nm]	*6	1.39								
Permitted Radial Load	[N]	*7	9600	9800	11000	11000	12000	12000	13000	13000	
Permitted Axial Load	[N]	*8	8700	8900	9900	11000	11000	12000	13000	13000	
Maximum Radial Load	[N]	*9	15000								
Maximum Axial Load	[N]	*10	14000								
Moment of Inertia (≤ Ø 28)	[kgcm ²]	--	4.700	5.400	4.400	4.200	4.900	3.200	4.100	3.200	
Moment of Inertia (≤ Ø 38)	[kgcm ²]	--	12.000	13.000	12.000	12.000	13.000	11.000	12.000	11.000	
Moment of Inertia (≤ Ø 48)	[kgcm ²]	--	34.000	35.000	34.000	34.000	35.000	33.000	34.000	33.000	
Moment of Inertia (≤ Ø 65)	[kgcm ²]	--	--	--	--	--	--	--	--	--	
Efficiency	[%]	*11	90								
Torsional Rigidity	[Nm/arc-min]	*12	175								
Maximum Torsional Backlash	[arc-min]	--	≤ 5								
Noise Level	[dB]	*13	67								
Protection Class	--	*14	IP54 (IP65)								
Ambient Temperature	[°C]	--	0-40								
Permitted Housing Temperature	[°C]	--	90								
Weight	[kg]	*15	40								

VRL-155 – 2-Stage Adapter Dimensions

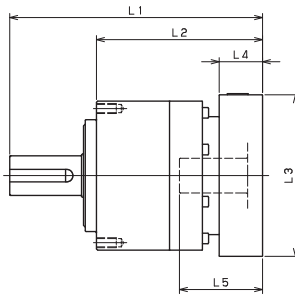

VRL

Model number	**: Adapter code	2-Stage					
		L1	L*	L2	L3	L4	L5
VRL-155-□-□-19** (Input shaft bore ≤ φ19)	DA-DB-DC	266.5	241.5	169.5	□80	25	50
	EB-ED	266.5	241.5	169.5	□90	25	50
	FA	266.5	241.5	169.5	□100	25	50
	FB	276.5	241.5	179.5	□100	35	60
	GB-GD-GJ	266.5	241.5	169.5	□115	25	50
	HA	266.5	241.5	169.5	□130	25	50
	HB	281.5	241.5	184.5	□130	40	65
VRL-155-□-□-28** (Input shaft bore ≤ φ28)	JA	276.5	241.5	179.5	□150	35	60
	FA+FB-FC	283.5	248.5	186.5	□100	35	67
	GA-GB-GC-GD-GE-GF-GG-GH	283.5	248.5	186.5	□115	35	67
	HA+HC-HD	283.5	248.5	186.5	□130	35	67
	HB	293.5	248.5	196.5	□130	45	77
	HF	278.5	248.5	181.5	□130	30	62
	JA+JB+JC+JF	283.5	248.5	186.5	□150	35	67
	KA-KB-KE	283.5	248.5	186.5	□180	35	67
	LA	283.5	248.5	186.5	□200	35	67
	LB	293.5	248.5	196.5	□200	45	77
VRL-155-□-□-38** (Input shaft bore ≤ φ38)	MA	283.5	248.5	186.5	□220	35	67
	MB	293.5	248.5	196.5	□220	45	77
	HA	298.5	253.5	201.5	□130	45	82
	HB-HE	293.5	253.5	196.5	□130	40	77
	JA	298.5	253.5	201.5	□150	45	82
	KA+KB-KC	298.5	253.5	201.5	□180	45	82
	KD	333.5	253.5	236.5	□180	80	117
	KE	313.5	253.5	216.5	□180	60	97
	LB	308.5	253.5	211.5	□200	55	92
	MA-MB	298.5	253.5	201.5	□220	45	82
VRL-155-□-□-48** (Input shaft bore ≤ φ48)	MC	313.5	253.5	216.5	□220	60	97
	MD	308.5	253.5	211.5	□220	55	92
	KA	339.5	264.5	242.5	□180	75	118
	KB-KC	319.5	264.5	222.5	□180	55	98
	LA	319.5	264.5	222.5	□200	55	98
	MA	319.5	264.5	222.5	□220	55	98
	MB	339.5	264.5	242.5	□220	75	118

*1) Double reduction : 1/15~ 1/100

*2) Bushing will be inserted to adapt to motor shaft

For an explanation on the Adapter Flange Code, please turn to page 422.

A more comprehensive adapter flange offering can be found using the NIDEC-SHIMPO Online Selector Tool. The variety is constantly expanding and being updated on the Selector Tool. If you have any questions or need any support, contact NIDEC-SHIMPO.

VRL-070 – 1-Stage Specifications

Frame Size	070											
Stage	1-Stage											
Ratio	Unit	Note	3	4	5	6	7	8	9	10		
Nominal Output Torque	[Nm]	*1	18	27	27	27	27	27	18	18		
Maximum Output Torque	[Nm]	*2	35	50	50	50	50	50	35	35		
Emergency Stop Torque	[Nm]	*3	80	100	100	100	100	100	80	80		
Nominal Input Speed	[rpm]	*4	3000									
Maximum Input Speed	[rpm]	*5	6000									
No Load Running Torque	[Nm]	*6	0.08									
Permitted Radial Load	[N]	*7	430	470	510	540	570	600	620	640		
Permitted Axial Load	[N]	*8	310	360	390	430	460	480	510	530		
Maximum Radial Load	[N]	*9	1200									
Maximum Axial Load	[N]	*10	1100									
Moment of Inertia (≤φ8)	[kgcm ²]	--	0.140	0.095	0.077	0.068	0.062	0.059	0.057	0.056		
Moment of Inertia (≤φ14)	[kgcm ²]	--	0.220	0.170	0.160	0.150	0.140	0.140	0.140	0.140		
Moment of Inertia (≤φ19)	[kgcm ²]	--	0.430	0.380	0.360	0.360	0.350	0.350	0.340	0.340		
Efficiency	[%]	*11	95									
Torsional Rigidity	[Nm/arcmin]	*12	3									
Maximum Torsional Backlash	[Arc-min]	--	≤ 5									
Noise Level	[dB]	*13	≤ 66									
Protection Class	--	*14	IP54 (IP65)									
Ambient Temperature	[°C]	--	0-40									
Permitted Housing Temperature	[°C]	--	90									
Weight	[kg]	*15	1.5									

VRL-070 – 2-Stage Specifications

Frame Size	070											
Stage	2-Stage											
Ratio	Unit	Note	15	16	20	25	28	30	35	40		
Nominal Output Torque	[Nm]	*1	18	27	27	27	27	18	27	27		
Maximum Output Torque	[Nm]	*2	35	50	50	50	50	35	50	50		
Emergency Stop Torque	[Nm]	*3	80	100	100	100	100	80	100	100		
Nominal Input Speed	[rpm]	*4	3000									
Maximum Input Speed	[rpm]	*5	6000									
No Load Running Torque	[Nm]	*6	0.04									
Permitted Radial Load	[N]	*7	740	750	810	870	910	930	980	1000		
Permitted Axial Load	[N]	*8	630	650	720	790	830	860	920	970		
Maximum Radial Load	[N]	*9	1200									
Maximum Axial Load	[N]	*10	1100									
Moment of Inertia (≤φ8)	[kgcm ²]	--	0.055	0.057	0.054	0.053	0.055	0.049	0.053	0.049		
Moment of Inertia (≤φ14)	[kgcm ²]	--	0.140	0.140	0.130	0.130	0.140	0.130	0.130	0.130		
Moment of Inertia (≤φ19)	[kgcm ²]	--	0.350	0.360	0.350	0.350	0.360	0.340	0.350	0.340		
Efficiency	[%]	*11	90									
Torsional Rigidity	[Nm/arcmin]	*12	3									
Maximum Torsional Backlash	[Arc-min]	--	≤ 5									
Noise Level	[dB]	*13	≤ 66									
Protection Class	--	*14	IP54 (IP65)									
Ambient Temperature	[°C]	--	0-40									
Permitted Housing Temperature	[°C]	--	90									
Weight	[kg]	*15	1.7									

VRL-070 – 2-Stage Specifications

Frame Size	070									
Stage	2-Stage									
Ratio	Unit	Note	45	50	60	70	80	90	100	
Nominal Output Torque	[Nm]	*1	18	27	27	27	27	18	18	
Maximum Output Torque	[Nm]	*2	35	50	50	50	50	35	35	
Emergency Stop Torque	[Nm]	*3	80	100	100	100	100	80	80	
Nominal Input Speed	[rpm]	*4	3000							
Maximum Input Speed	[rpm]	*5	6000							
No Load Running Torque	[Nm]	*6	0.04							
Permitted Radial Load	[N]	*7	1100	1100	1200	1200	1200	1200	1200	
Permitted Axial Load	[N]	*8	1000	1100	1100	1100	1100	1100	1100	
Maximum Radial Load	[N]	*9	1200							
Maximum Axial Load	[N]	*10	1100							
Moment of Inertia (≤Ø 8)	[kgcm ²]	--	0.053	0.049	0.049	0.049	0.049	0.049	0.049	
Moment of Inertia (≤ Ø 14)	[kgcm ²]	--	0.130	0.130	0.130	0.130	0.130	0.13	0.13	
Moment of Inertia (≤ Ø 19)	[kgcm ²]	--	0.350	0.340	0.340	0.340	0.340	0.340	0.340	
Efficiency	[%]	*11	90							
Torsional Rigidity	[Nm/arcmin]	*12	3							
Maximum Torsional Backlash	[Arc-min]	--	≤ 5							
Noise Level	[dB]	*13	≤ 66							
Protection Class	--	*14	IP54 (IP65)							
Ambient Temperature	[°C]	--	0-40							
Permitted Housing Temperature	[°C]	--	90							
Weight	[kg]	*15	1.7							

- *1) At nominal input speed, service life is 20,000 hours
- *2) The maximum torque when starting or stopping operation
- *3) The maximum torque allowed under a stress situation (Permitted 1,000 times during service life)
- *4) The average input speed
- *5) The maximum intermittent input speed
- *6) This is the torque at no load applied on the input shaft. The input speed is 3,000 rpm for VRL 070
- *7) At this load and nominal input speed, service life will be 20,000 hours. (The radial load applied to the output side bearing)
- *8) At this load and nominal input speed, service life will be 20,000 hours. (The axial load applied to the output shaft center)
- *9) The maximum radial load that the reducer can accept
- *10) The maximum axial load that the reducer can accept
- *11) The efficiency at the nominal torque rating
- *12) This does not include the lost motion
- *13) Contact NIDEC-SHIMPO for the testing conditions and environment
- *14) IP65 (wash-down) is available as an option. Contact NIDEC-SHIMPO for more details and our food grade options
- *15) The weight may vary slightly between models

VRL

VRL-155 – 1-Stage Adapter Dimensions

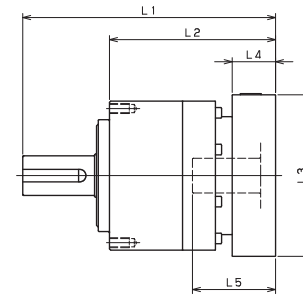

Model number	**: Adapter code	1-Stage					
		L1	L*	L2	L3	L4	L5
VRL-155-□-□-19** (Input shaft bore ≤ φ19)	DA-DB-DC	--	--	--	--	--	--
	EB-ED	--	--	--	--	--	--
	FA	--	--	--	--	--	--
	FB	--	--	--	--	--	--
	GB-GD-GJ	--	--	--	--	--	--
	HA	--	--	--	--	--	--
	HB	--	--	--	--	--	--
VRL-155-□-□-28** (Input shaft bore ≤ φ28)	FA-FB-FC	249	214	152	□100	35	67
	GA-GB-GC-GD-GE-GF-GG-GH	249	214	152	□115	35	67
	HA-HC-HD	249	214	152	□130	35	67
	HB	259	214	162	□130	45	77
	HF	244	214	147	□130	30	62
	JA-JB-JC-JF	249	214	152	□150	35	67
	KA-KB-KE	249	214	152	□180	35	67
	LA	249	214	152	□200	35	67
	LB	259	214	162	□200	45	77
	MA	249	214	152	□220	35	67
VRL-155-□-□-38** (Input shaft bore ≤ φ38)	MB	259	214	162	□220	45	77
	HA	264	219	167	□130	45	82
	HB-HE	259	219	162	□130	40	77
	JA	264	219	167	□150	45	82
	KA-KB-KC	264	219	167	□180	45	82
	KD	299	219	202	□180	80	117
	KE	279	219	182	□180	60	97
	LB	274	219	177	□200	55	92
	MA-MB	264	219	167	□220	45	82
	MC	279	219	182	□220	60	97
VRL-155-□-□-48** (Input shaft bore ≤ φ48)	MD	274	219	177	□220	55	92
	KA	305	230	208	□180	75	118
	KB-KC	285	230	188	□180	55	98
	LA	285	230	188	□200	55	98
	MA	285	230	188	□220	55	98
MB	305	230	208	□220	75	118	

*1) Single reduction : 1/3~ 1/10 *2) Bushing will be inserted to adapt to motor shaft

For an explanation on the Adapter Flange Code, please turn to page 422.

A more comprehensive adapter flange offering can be found using the NIDEC-SHIMPO Online Selector Tool. The variety is constantly expanding and being updated on the Selector Tool. If you have any questions or need any support, contact NIDEC-SHIMPO.

VRL

VRL-155 - 2-Stage Dimensions

Input shaft bore $\leq \phi 19$

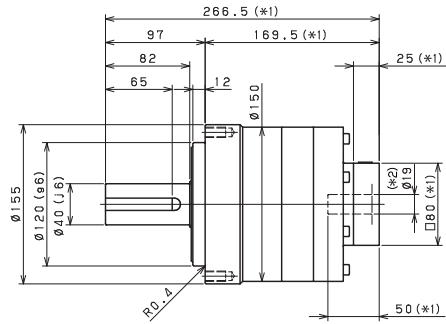
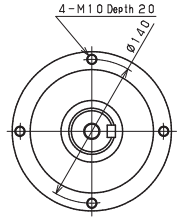

Input shaft bore $\leq \phi 28$

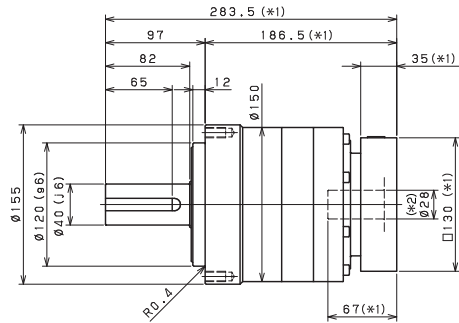
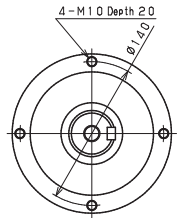

Input shaft bore $\leq \phi 38$

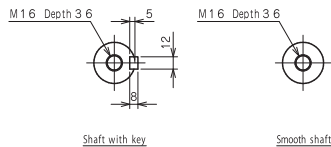
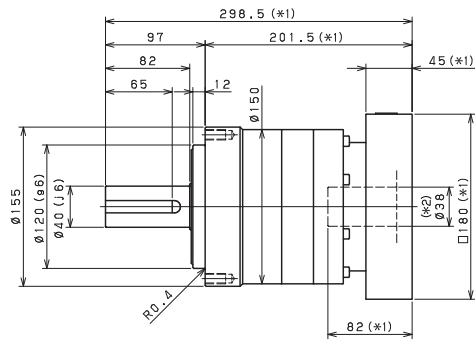
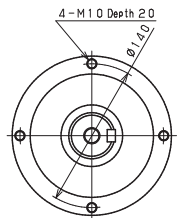

- *1) Length will vary depending on motor
- *2) Bushing will be inserted to adapt to motor shaft

VRL-070 - 1-Stage Dimensions

Input shaft bore $\leq \phi 8$

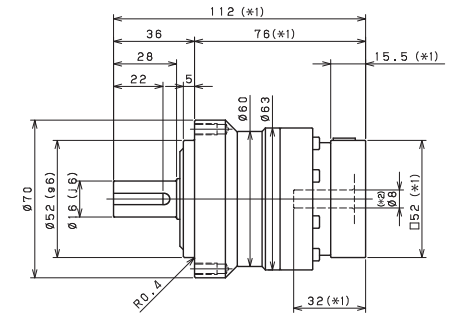
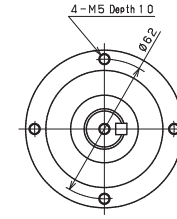

Input shaft bore $\leq \phi 14$

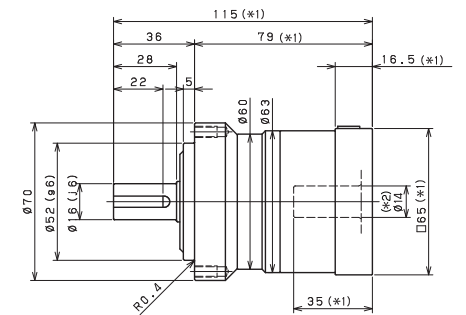
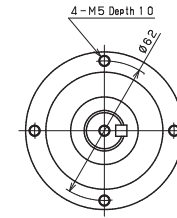

Input shaft bore $\leq \phi 19$

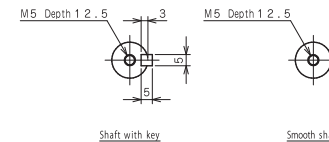
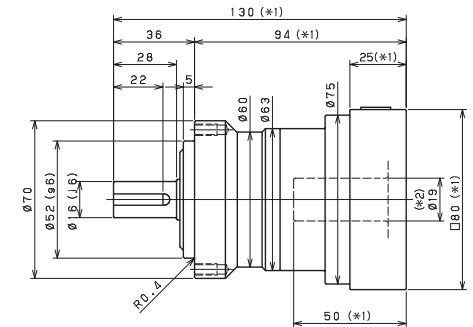
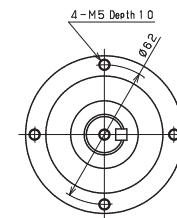

- *1) Length will vary depending on motor
- *2) Bushing will be inserted to adapt to motor shaft

VRL-070 - 2-Stage Dimensions

Input shaft bore $\leq \phi 8$

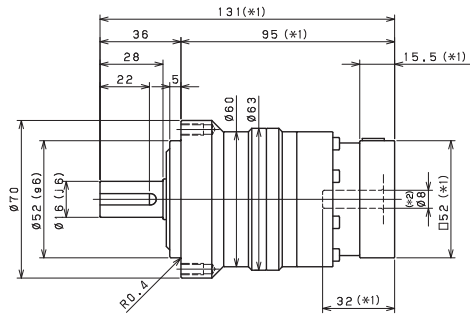
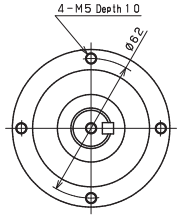

Input shaft bore $\leq \phi 14$

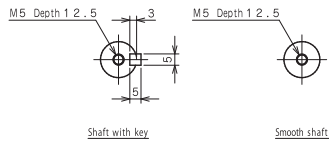
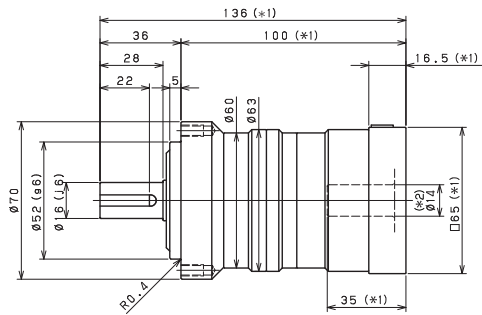
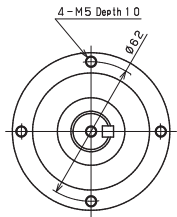

- *1) Length will vary depending on motor
- *2) Bushing will be inserted to adapt to motor shaft

VRL

VRL-155 - 1-Stage Dimensions

Input shaft bore $\leq \phi 28$

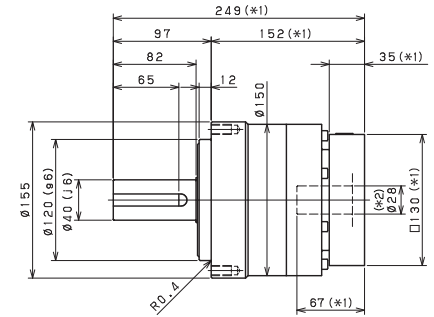
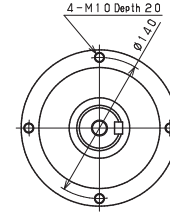

Input shaft bore $\leq \phi 38$

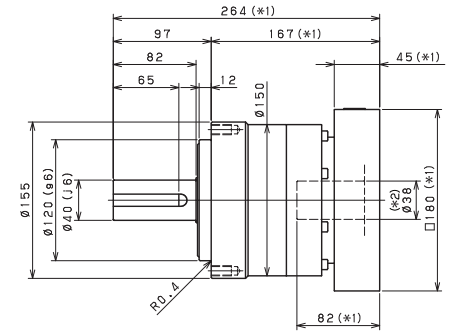
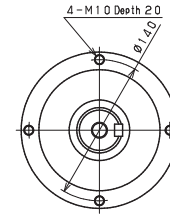

Input shaft bore $\leq \phi 48$

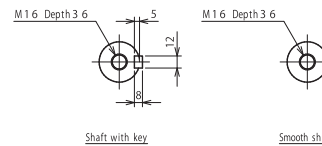
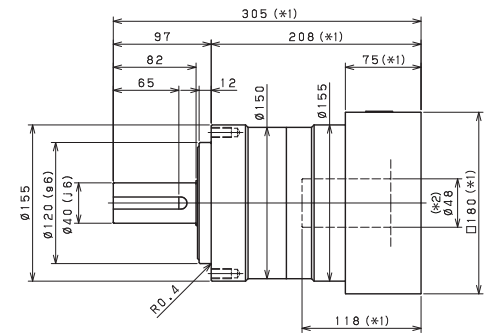
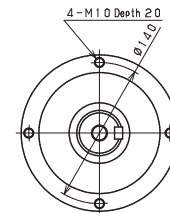

- *1) Length will vary depending on motor
- *2) Bushing will be inserted to adapt to motor shaft

VRL-155 – 2-Stage Specifications

Frame Size	155										
Stage	2-Stage										
Ratio	Unit	Note	45	50	60	70	80	90	100		
Nominal Output Torque	[Nm]	*1	240	360	360	360	360	240	240		
Maximum Acceleration Torque	[Nm]	*2	470	700	700	700	700	470	470		
Emergency Stop Torque	[Nm]	*3	1000	1250	1250	1250	1250	1000	1000		
Nominal Input Speed	[rpm]	*4	2000								
Maximum Input Speed	[rpm]	*5	4000								
No Load Running Torque	[Nm]	*6	0.56								
Permitted Radial Load	[N]	*7	7800	8100	8600	9100	9100	9100	9100		
Permitted Axial Load	[N]	*8	7900	8200	8200	8200	8200	8200	8200		
Maximum Radial Load	[N]	*9	9100								
Maximum Axial Load	[N]	*10	8200								
Moment of Inertia (≤ Ø 19)	[kgcm ²]	--	1.100	0.810	0.810	0.800	0.800	0.800	0.800		
Moment of Inertia (≤ Ø 28)	[kgcm ²]	--	3.000	2.800	2.800	2.800	2.800	2.800	2.800		
Moment of Inertia (≤ Ø 38)	[kgcm ²]	--	11.000	10.000	10.000	10.000	10.000	10.000	10.000		
Moment of Inertia (≤ Ø 48)	[kgcm ²]	--	--	--	--	--	--	--	--		
Efficiency	[%]	*11	90								
Torsional Rigidity	[Nm/arc-min]	*12	60								
Maximum Torsional Backlash	[arc-min]	--	≤ 5								
Noise Level	[dB]	*13	67								
Protection Class	--	*14	IP54 (IP65)								
Ambient Temperature	[°C]	--	0-40								
Permitted Housing Temperature	[°C]	--	90								
Weight	[kg]	*15	18								

- *1) At nominal input speed, service life is 20,000 hours
- *2) The maximum torque when starting or stopping operation
- *3) The maximum torque allowed under a stress situation (Permitted 1,000 times during service life)
- *4) The average input speed
- *5) The maximum intermittent input speed
- *6) This is the torque at no load applied on the input shaft. The input speed is 2,000 rpm for VRL155
- *7) At this load and nominal input speed, service life will be 20,000 hours. (The radial load applied to the output side bearing)
- *8) At this load and nominal input speed, service life will be 20,000 hours. (The axial load applied to the output shaft center)
- *9) The maximum radial load that the reducer can accept
- *10) The maximum axial load that the reducer can accept
- *11) The efficiency at the nominal torque rating
- *12) This does not include the lost motion
- *13) Contact NIDEC-SHIMPO for the testing conditions and environment
- *14) IP65 (wash-down) is available as an option. Contact NIDEC-SHIMPO for more details and our food grade options
- *15) The weight may vary slightly between models

VRL

VRL-070 – 1-Stage Adapter Dimensions

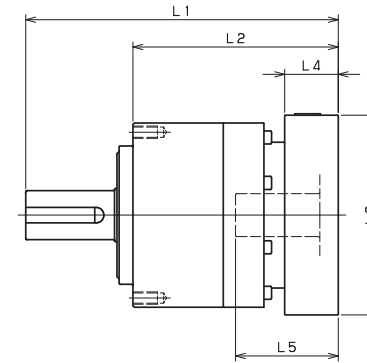

Model number	**: Adapter code	1-Stage					
		L1	L*	L2	L3	L4	L5
VRL-070-□-□-8** (Input shaft bore ≤ φ8)	AA-AC-AD-AF-AG-AL-AM-AN-AQ	112	96.5	76	□52	15.5	32
	AB-AE-AH-AJ-AK	117	96.5	81	□52	20.5	37
	BA-BB-BD-BE-BG-BH-BJ	112	96.5	76	□60	15.5	32
	BC-BF	117	96.5	81	□60	20.5	37
	CA	117	96.5	81	□70	20.5	37
VRL-070-□-□-14** (Input shaft bore ≤ φ14)	BA-BB-BD-BE-BF-BG-BH-BJ-BK-BP	115	98.5	79	□65	16.5	35
	BC-BH-BM-BN	120	98.5	84	□65	21.5	40
	BL	125	98.5	89	□65	26.5	45
	CA-CC	115	98.5	79	□70	16.5	35
	CB	120	98.5	84	□70	21.5	40
	DA-DB-DC-DD-DF-DH-DJ	115	98.5	79	□80	16.5	35
	DE-DL	120	98.5	84	□80	21.5	40
	DG-DK	125	98.5	89	□80	26.5	45
	EA-EB-EC-EF-EG-EK-EL	115	98.5	79	□90	16.5	35
	EJ-EM	120	98.5	84	□90	21.5	40
ED-EE-EH	125	98.5	89	□90	26.5	45	
	FA	115	98.5	79	□100	16.5	35
	FB	115	98.5	79	□115	16.5	35
VRL-070-□-□-19** (Input shaft bore ≤ φ19)	DA-DB-DC	130	105	94	□80	25	50
	DD	140	105	104	□80	35	60
	DE	135	105	99	□80	30	55
	EA	135	105	99	□90	30	55
	EB-ED	130	105	94	□90	25	50
	EC	140	105	104	□90	35	60
	FA	130	105	94	□100	25	50
	FB	140	105	104	□100	35	60

- *1) Single reduction : 1/3~ 1/10
- *2) Bushing will be inserted to adapt to motor shaft

For an explanation on the Adapter Flange Code, please turn to page 422.

A more comprehensive adapter flange offering can be found using the NIDEC-SHIMPO Online Selector Tool. The variety is constantly expanding and being updated on the Selector Tool. If you have any questions or need any support, contact NIDEC-SHIMPO.

VRL-070 – 2-Stage Adapter Dimensions

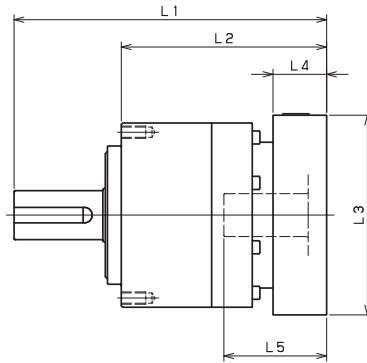

VRL

Model number	**: Adapter code	2-Stage					
		L1	L*	L2	L3	L4	L5
VRL-070-□-□-8** (Input shaft bore ≤ φ8)	AA-AC-AD-AF-AG-AL-AM-AN-AQ	131	115.5	95	□52	15.5	32
	AB-AE-AH-AJ-AK	136	115.5	100	□52	20.5	37
	BA-BB-BD-BE-BG-BH-BJ	131	115.5	95	□60	15.5	32
	BC-BF	136	115.5	100	□60	20.5	37
	CA	136	115.5	100	□70	20.5	37
VRL-070-□-□-14** (Input shaft bore ≤ φ14)	BA-BB-BD-BE-BF-BG-BH-BJ-BK-BP	136	119.5	100	□65	16.5	35
	BC-BH-BM-BN	141	119.5	105	□65	21.5	40
	BL	146	119.5	110	□65	26.5	45
	CA-CC	136	119.5	100	□70	16.5	35
	CB	141	119.5	105	□70	21.5	40
	DA-DB-DC-DD-DF-DH-DJ	136	119.5	100	□80	16.5	35
	DE-DL	141	119.5	105	□80	21.5	40
	DG-DK	146	119.5	110	□80	26.5	45
	EA-EB-EC-EF-EG-EK-EL	136	119.5	100	□90	16.5	35
	EJ-EM	141	119.5	105	□90	21.5	40
	ED-EE-EH	146	119.5	110	□90	26.5	45
	FA	136	119.5	100	□100	16.5	35
	FB	136	119.5	100	□115	16.5	35
VRL-070-□-□-19** (Input shaft bore ≤ φ19)	DA-DB-DC	151	126	115	□80	25	50
	DD	161	126	125	□80	35	60
	DE	156	126	120	□80	30	55
	EA	156	126	120	□90	30	55
	EB-ED	151	126	115	□90	25	50
	EC	161	126	125	□90	35	60
	FA	151	126	115	□100	25	50
FB	161	126	125	□100	35	60	

*1) Double reduction : 1/15~ 1/100

*2) Bushing will be inserted to adapt to motor shaft

For an explanation on the Adapter Flange Code, please turn to page 422.

A more comprehensive adapter flange offering can be found using the NIDEC-SHIMPO Online Selector Tool. The variety is constantly expanding and being updated on the Selector Tool. If you have any questions or need any support, contact NIDEC-SHIMPO.

VRL-155 – 1-Stage Specifications

Frame Size		155									
Stage		1-Stage									
Ratio	Unit	Note	3	4	5	6	7	8	9	10	
Nominal Output Torque	[Nm]	*1	240	240	360	360	360	360	240	240	
Maximum Acceleration Torque	[Nm]	*2	470	700	700	700	700	700	470	470	
Emergency Stop Torque	[Nm]	*3	1000	1250	1250	1250	1250	1250	1000	1000	
Nominal Input Speed	[rpm]	*4	2000								
Maximum Input Speed	[rpm]	*5	4000								
No Load Running Torque	[Nm]	*6	1.63								
Permitted Radial Load	[N]	*7	3200	3500	3800	4000	4200	4400	4600	4700	
Permitted Axial Load	[N]	*8	2400	2700	3000	3300	3500	3700	3900	4100	
Maximum Radial Load	[N]	*9	9100								
Maximum Axial Load	[N]	*10	8200								
Moment of Inertia (≤ Ø 19)	[kgcm ²]	--	--	--	--	--	--	--	--	--	
Moment of Inertia (≤ Ø 28)	[kgcm ²]	--	12.000	7.500	5.800	4.900	4.100	3.800	3.600	3.500	
Moment of Inertia (≤ Ø 38)	[kgcm ²]	--	20.000	15.000	14.000	13.000	12.000	12.000	11.000	11.000	
Moment of Inertia (≤ Ø 48)	[kgcm ²]	--	42.000	37.000	36.000	35.000	34.000	34.000	34.000	34.000	
Efficiency	[%]	*11	95								
Torsional Rigidity	[Nm/arc-min]	*12	60								
Maximum Torsional Backlash	[arc-min]	--	≤ 5								
Noise Level	[dB]	*13	67								
Protection Class	--	*14	IP54 (IP65)								
Ambient Temperature	[°C]	--	0-40								
Permitted Housing Temperature	[°C]	--	90								
Weight	[kg]	*15	16								

VRL-155 – 2-Stage Specifications

Frame Size		155										
Stage		2-Stage										
Ratio	Unit	Note	15	16	20	25	28	30	35	40		
Nominal Output Torque	[Nm]	*1	240	360	360	360	360	240	360	360		
Maximum Acceleration Torque	[Nm]	*2	470	700	700	700	700	470	700	700		
Emergency Stop Torque	[Nm]	*3	1000	1250	1250	1250	1250	1000	1250	1250		
Nominal Input Speed	[rpm]	*4	2000									
Maximum Input Speed	[rpm]	*5	4000									
No Load Running Torque	[Nm]	*6	0.56									
Permitted Radial Load	[N]	*7	5400	5500	6000	6400	6700	6800	7200	7500		
Permitted Axial Load	[N]	*8	4900	5000	5500	6100	6400	6600	7000	7500		
Maximum Radial Load	[N]	*9	9100									
Maximum Axial Load	[N]	*10	8200									
Moment of Inertia (≤ Ø 19)	[kgcm ²]	--	1.300	1.500	1.200	1.100	1.400	0.850	1.100	0.830		
Moment of Inertia (≤ Ø 28)	[kgcm ²]	--	3.200	3.500	3.100	3.100	3.300	2.800	3.100	2.800		
Moment of Inertia (≤ Ø 38)	[kgcm ²]	--	11.000	11.000	11.000	11.000	11.000	10.000	11.000	10.000		
Moment of Inertia (≤ Ø 48)	[kgcm ²]	--	--	--	--	--	--	--	--	--		
Efficiency	[%]	*11	90									
Torsional Rigidity	[Nm/arc-min]	*12	60									
Maximum Torsional Backlash	[arc-min]	--	≤ 5									
Noise Level	[dB]	*13	67									
Protection Class	--	*14	IP54 (IP65)									
Ambient Temperature	[°C]	--	0-40									
Permitted Housing Temperature	[°C]	--	90									
Weight	[kg]	*15	18									

VRL-120 – 2-Stage Adapter Dimensions

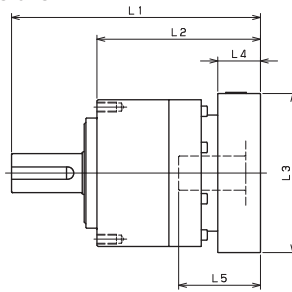

VRL

Model number	**: Adapter code	2-Stage					
		L1	L*	L2	L3	L4	L5
VRL-120-□-□-14** (Input shaft bore ≤ φ14)	BA-BB-BD-BE-BF-BG-BH-BJ-BK-BP	204.5	188	134.5	□65	16.5	35
	BC-BH-BM-BN	209.5	188	139.5	□65	21.5	40
	CA-CC	204.5	188	134.5	□70	16.5	35
	DA-DB-DC-DD-DF-DH-DJ	204.5	188	134.5	□80	16.5	35
	EA-EB-EC-EF-EG-EK-EL	204.5	188	134.5	□90	16.5	35
	FA	204.5	188	134.5	□100	16.5	35
	FB	214.5	188	144.5	□100	26.5	45
VRL-120-□-□-19** (Input shaft bore ≤ φ19)	JA	219.5	188	149.5	□150	31.5	50
	DA-DB-DC	214.5	189.5	144.5	□80	25	50
	EB	214.5	189.5	144.5	□90	25	50
	FA	214.5	189.5	144.5	□100	25	50
	FB	224.5	189.5	154.5	□100	35	60
	GB-GD	214.5	189.5	144.5	□115	25	50
	HA	224.5	189.5	154.5	□115	35	60
	--	214.5	189.5	144.5	□130	25	50
	--	229.5	189.5	159.5	□130	40	65
	--	219.5	189.5	149.5	□130	30	55
	HB	224.5	189.5	154.5	□150	35	60
VRL-120-□-□-28** (Input shaft bore ≤ φ28)	HC-HD-HE	229.5	189.5	159.5	□150	40	65
	FA-FB-FC	231.5	196.5	161.5	□100	35	67
	GA-GB-GC-GD-GE-GF-GG-GH	231.5	196.5	161.5	□115	35	67
	HA-HC-HD	231.5	196.5	161.5	□130	35	67
	HB	241.5	196.5	171.5	□130	45	77
	HF	226.5	196.5	156.5	□130	30	62
	JA-JB-JC-JF	231.5	196.5	161.5	□150	35	67
	JE	241.5	196.5	171.5	□150	45	77
	KA-KB-KE	231.5	196.5	161.5	□180	35	67
	KD	241.5	196.5	171.5	□180	45	77
VRL-120-□-□-38** (Input shaft bore ≤ φ38)	HA	249	204	179	□130	45	82
	HB-HE	244	204	174	□130	40	77
	JA	249	204	179	□150	45	82
	KA-KB-KC	249	204	179	□180	45	82
	KD	284	204	214	□180	80	117
KE	264	204	194	□180	60	97	

*1) Double reduction : 1/15~ 1/100 *2) Bushing will be inserted to adapt to motor shaft

For an explanation on the Adapter Flange Code, please turn to page 422.

A more comprehensive adapter flange offering can be found using the NIDEC-SHIMPO Online Selector Tool. The variety is constantly expanding and being updated on the Selector Tool. If you have any questions or need any support, contact NIDEC-SHIMPO.

VRL-090 – 1-Stage Specifications

Frame Size		090									
Stage		1-Stage									
Ratio	Unit	Note	3	4	5	6	7	8	9	10	
Nominal Output Torque	[Nm]	*1	50	75	75	75	75	75	50	50	
Maximum Acceleration Torque	[Nm]	*2	80	125	125	125	125	125	80	80	
Emergency Stop Torque	[Nm]	*3	200	250	250	250	250	250	200	200	
Nominal Input Speed	[rpm]	*4	3000								
Maximum Input Speed	[rpm]	*5	6000								
No Load Running Torque	[Nm]	*6	0.35								
Permitted Radial Load	[N]	*7	810	890	960	1000	1100	1100	1200	1200	
Permitted Axial Load	[N]	*8	930	1100	1200	1300	1300	1400	1500	1600	
Maximum Radial Load	[N]	*9	2400								
Maximum Axial Load	[N]	*10	2200								
Moment of Inertia (≤ Ø 8)	[kgcm ²]	--	--	--	--	--	--	--	--	--	
Moment of Inertia (≤ Ø 14)	[kgcm ²]	--	0.720	0.490	0.400	0.360	0.320	0.310	0.290	0.290	
Moment of Inertia (≤ Ø 19)	--	--	1.200	0.950	0.860	0.820	0.790	0.770	0.760	0.750	
Moment of Inertia (≤ Ø 28)	[kgcm ²]	--	3.200	3.000	2.900	2.800	2.800	2.800	2.800	2.800	
Efficiency	[%]	*11	95								
Torsional Rigidity	[Nm/arc-min]	*12	10								
Maximum Torsional Backlash	[arc-min]	--	≤ 5								
Noise Level	[dB]	*13	67								
Protection Class	--	*14	IP54 (IP65)								
Ambient Temperature	[°C]	--	0-40								
Permitted Housing Temperature	[°C]	--	90								
Weight	[kg]	*15	3.5								

VRL-090 – 2-Stage Specifications

Frame Size		090										
Stage		2-Stage										
Ratio	Unit	Note	15	16	20	25	28	30	35	40		
Nominal Output Torque	[Nm]	*1	50	75	75	75	75	50	75	75		
Maximum Acceleration Torque	[Nm]	*2	80	125	125	125	125	80	125	125		
Emergency Stop Torque	[Nm]	*3	200	250	250	250	250	200	250	250		
Nominal Input Speed	[rpm]	*4	3000									
Maximum Input Speed	[rpm]	*5	6000									
No Load Running Torque	[Nm]	*6	0.06									
Permitted Radial Load	[N]	*7	1400	1400	1500	1600	1700	1700	1800	1900		
Permitted Axial Load	[N]	*8	1900	1900	2100	2200	2200	2200	2200	2200		
Maximum Radial Load	[N]	*9	2400									
Maximum Axial Load	[N]	*10	2200									
Moment of Inertia (≤ Ø 8)	[kgcm ²]	--	0.130	0.150	0.130	0.120	0.140	0.100	0.120	0.099		
Moment of Inertia (≤ Ø 14)	[kgcm ²]	--	0.280	0.300	0.280	0.280	0.290	0.250	0.270	0.250		
Moment of Inertia (≤ Ø 19)	--	--	0.720	0.740	0.720	0.710	0.730	0.700	0.710	0.700		
Moment of Inertia (≤ Ø 28)	[kgcm ²]	--	2.700	2.800	2.700	2.700	2.700	2.600	2.700	2.600		
Efficiency	[%]	*11	90									
Torsional Rigidity	[Nm/arc-min]	*12	10									
Maximum Torsional Backlash	[arc-min]	--	≤ 5									
Noise Level	[dB]	*13	67									
Protection Class	--	*14	IP54 (IP65)									
Ambient Temperature	[°C]	--	0-40									
Permitted Housing Temperature	[°C]	--	90									
Weight	[kg]	*15	4									

VRL-090 – 2-Stage Specifications

Frame Size	090										
Stage	2-Stage										
Ratio	Unit	Note	45	50	60	70	80	90	100		
Nominal Output Torque	[Nm]	*1	50	75	75	75	75	50	50		
Maximum Acceleration Torque	[Nm]	*2	80	125	125	125	125	80	80		
Emergency Stop Torque	[Nm]	*3	200	250	250	250	250	200	200		
Nominal Input Speed	[rpm]	*4	3000								
Maximum Input Speed	[rpm]	*5	6000								
No Load Running Torque	[Nm]	*6	0.06								
Permitted Radial Load	[N]	*7	2000	2100	2200	2300	2400	2400	2400		
Permitted Axial Load	[N]	*8	2200	2200	2200	2200	2200	2200	2200		
Maximum Radial Load	[N]	*9	2400								
Maximum Axial Load	[N]	*10	2200								
Moment of Inertia (≤ Ø 8)	[kgcm ²]	--	0.120	0.098	0.098	0.097	0.097	0.097	0.097		
Moment of Inertia (≤ Ø 14)	[kgcm ²]	--	0.270	0.250	0.250	0.250	0.250	0.250	0.250		
Moment of Inertia (≤ Ø 19)	--	--	0.710	0.690	0.690	0.690	0.690	0.690	0.690		
Moment of Inertia (≤ Ø 28)	[kgcm ²]	--	2.700	2.600	2.600	2.600	2.600	2.600	2.600		
Efficiency	[%]	*11	90								
Torsional Rigidity	[Nm/arc-min]	*12	10								
Maximum Torsional Backlash	[arc-min]	--	≤ 5								
Noise Level	[dB]	*13	67								
Protection Class	--	*14	IP54 (IP65)								
Ambient Temperature	[°C]	--	0-40								
Permitted Housing Temperature	[°C]	--	90								
Weight	[kg]	*15	4								

- *1) At nominal input speed, service life is 20,000 hours
- *2) The maximum torque when starting or stopping operation
- *3) The maximum torque allowed under a stress situation (Permitted 1,000 times during service life)
- *4) The average input speed
- *5) The maximum intermittent input speed
- *6) This is the torque at no load applied on the input shaft. The input speed is 3,000 rpm for VRL 090
- *7) At this load and nominal input speed, service life will be 20,000 hours. (The radial load applied to the output side bearing)
- *8) At this load and nominal input speed, service life will be 20,000 hours. (The axial load applied to the output shaft center)
- *9) The maximum radial load that the reducer can accept
- *10) The maximum axial load that the reducer can accept
- *11) The efficiency at the nominal torque rating
- *12) This does not include the lost motion
- *13) Contact NIDEC-SHIMPO for the testing conditions and environment
- *14) IP65 (wash-down) is available as an option. Contact NIDEC-SHIMPO for more details and our food grade options
- *15) The weight may vary slightly between models

VRL

VRL-120 – 1-Stage Adapter Dimensions

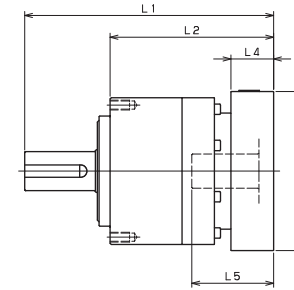

Model number	**: Adapter code	1-Stage					
		L1	L*	L2	L3	L4	L5
VRL-120-□-□-14** (Input shaft bore ≤ φ14)	BA-BB-BD-BE-BF-BG-BH-BJ-BK-BP	--	--	--	--	--	--
	BC-BH-BM-BN	--	--	--	--	--	--
	CA-CC	--	--	--	--	--	--
	DA-DB-DC-DD-DF-DH-DJ	--	--	--	--	--	--
	EA-EB-EC-EF-EG-EK-EL	--	--	--	--	--	--
	FA	--	--	--	--	--	--
VRL-120-□-□-19** (Input shaft bore ≤ φ19)	FB	--	--	--	--	--	--
	JA	--	--	--	--	--	--
	DA-DB-DC	187	162	117	□80	25	50
	EB	187	162	117	□90	25	50
	FA	187	162	117	□100	25	50
	FB	197	162	127	□100	35	60
	GB-GD	187	162	117	□115	25	50
	HA	197	162	127	□115	35	60
	--	187	162	117	□130	25	50
	--	202	162	132	□130	40	65
	--	192	162	122	□130	30	55
	HB	197	162	127	□150	35	60
HC-HD-HE	202	162	132	□150	40	65	
VRL-120-□-□-28** (Input shaft bore ≤ φ28)	FA-FB-FC	204	169	134	□100	35	67
	GA-GB-GC-GD-GE-GF-GG-GH	204	169	134	□115	35	67
	HA-HC-HD	204	169	134	□130	35	67
	HB	214	169	144	□130	45	77
	HF	199	169	129	□130	30	62
	JA-JB-JC-JF	204	169	134	□150	35	67
	JE	214	169	144	□150	45	77
	KA-KB-KE	204	169	134	□180	35	67
	KD	214	169	144	□180	45	77
VRL-120-□-□-38** (Input shaft bore ≤ φ38)	HA	225	180	155	□130	45	82
	HB-HE	220	180	150	□130	40	77
	JA	225	180	155	□150	45	82
	KA-KB-KC	225	180	155	□180	45	82
	KD	260	180	190	□180	80	117
KE	240	180	170	□180	60	97	

*1) Single reduction : 1/3~ 1/10 *2) Bushing will be inserted to adapt to motor shaft

For an explanation on the Adapter Flange Code, please turn to page 422.

A more comprehensive adapter flange offering can be found using the NIDEC-SHIMPO Online Selector Tool. The variety is constantly expanding and being updated on the Selector Tool. If you have any questions or need any support, contact NIDEC-SHIMPO.

VRL-120 - 2-Stage Dimensions

Input shaft bore $\leq \phi 14$

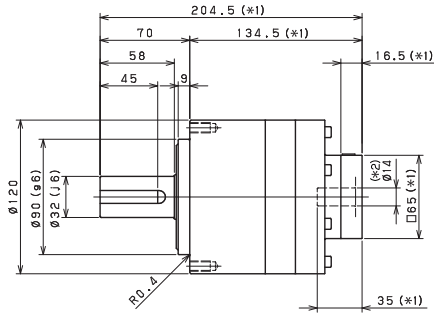
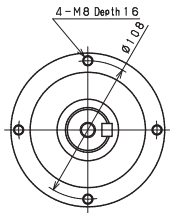

Input shaft bore $\leq \phi 19$

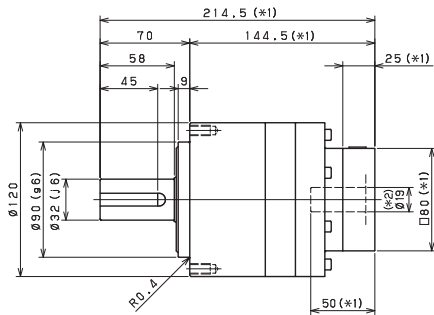
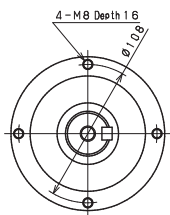

Input shaft bore $\leq \phi 28$

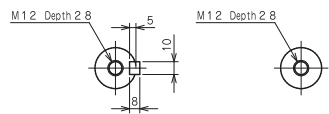
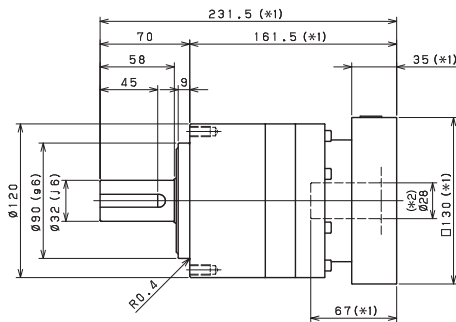
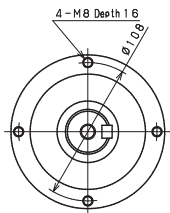

Shaft with key Smooth shaft

- *1) Length will vary depending on motor
- *2) Bushing will be inserted to adapt to motor shaft

VRL

VRL-090 - 1-Stage Dimensions

Input shaft bore $\leq \phi 14$

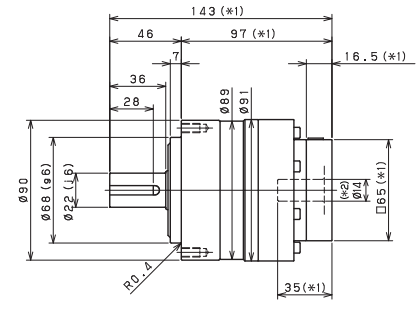
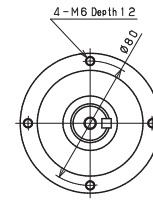

Input shaft bore $\leq \phi 19$

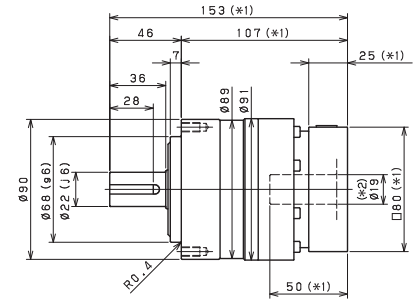
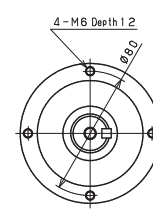

Input shaft bore $\leq \phi 28$

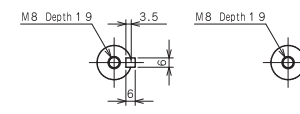
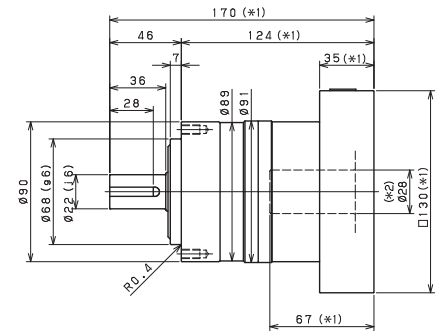
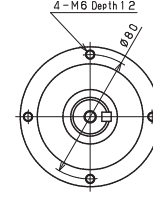

Shaft with key Smooth shaft

- *1) Length will vary depending on motor
- *2) Bushing will be inserted to adapt to motor shaft

VRL

VRL-090 – 2-Stage Dimensions

Input shaft bore $\leq \varnothing 8$

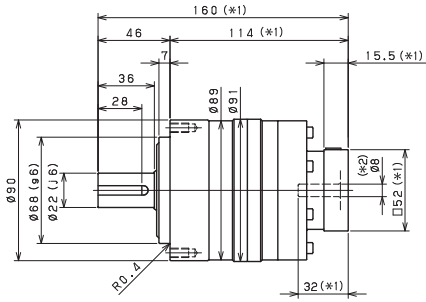
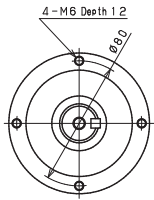

Input shaft bore $\leq \varnothing 14$

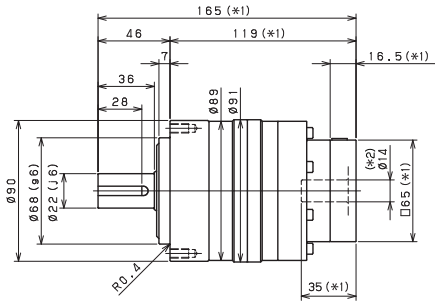
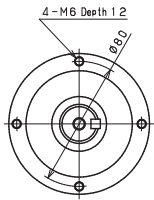

Input shaft bore $\leq \varnothing 19$

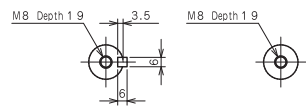
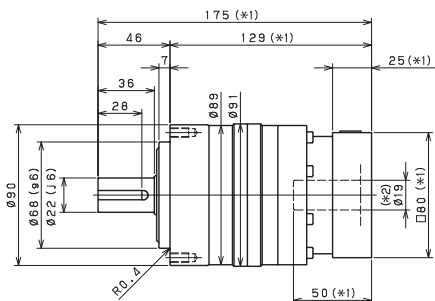
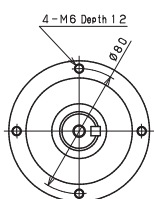

Shaft with key

Smooth shaft

- *1) Length will vary depending on motor
- *2) Bushing will be inserted to adapt to motor shaft

VRL-120 – 1-Stage Dimensions

Input shaft bore $\leq \varnothing 19$

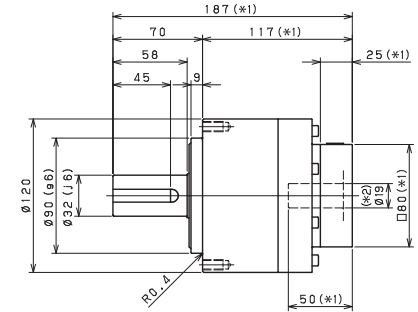
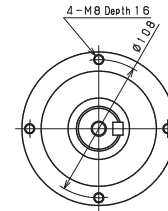

Input shaft bore $\leq \varnothing 28$

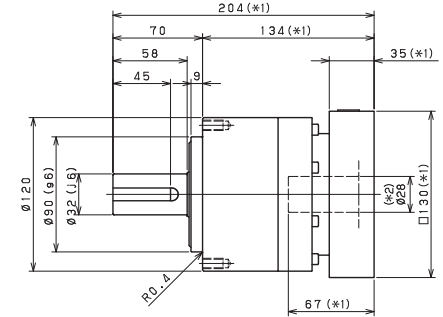
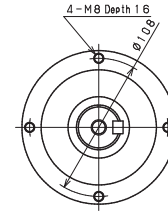

Input shaft bore $\leq \varnothing 38$

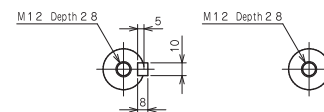
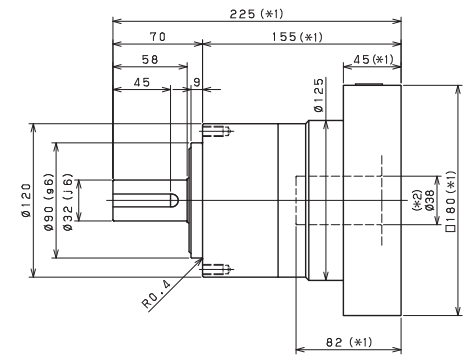
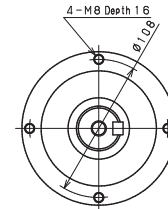

Shaft with key

Smooth shaft

- *1) Length will vary depending on motor
- *2) Bushing will be inserted to adapt to motor shaft

VRL-120 – 2-Stage Specifications

Frame Size	120										
Stage	2-Stage										
Ratio	Unit	Note	45	50	60	70	80	90	100		
Nominal Output Torque	[Nm]	*1	120	180	180	180	180	120	120		
Maximum Output Torque	[Nm]	*2	225	330	330	330	330	225	225		
Emergency Stop Torque	[Nm]	*3	500	625	625	625	625	500	500		
Nominal Input Speed	[rpm]	*4	3000								
Maximum Input Speed	[rpm]	*5	6000								
No Load Running Torque	[Nm]	*14	0.42								
Permitted Radial Load	[N]	*6	3300	3400	3600	3800	4000	4200	4300		
Permitted Axial Load	[N]	*7	3900	3900	3900	3900	3900	3900	3900		
Maximum Radial Load	[N]	*8	4300								
Maximum Axial Load	[N]	*9	3900								
Moment of Inertia (≤Ø 14)	[kgcm ²]		0.370	0.280	0.280	0.280	0.280	0.270	0.270		
Moment of Inertia (≤ Ø 19)	[kgcm ²]		0.800	0.730	0.730	0.730	0.730	0.730	0.730		
Moment of Inertia (≤ Ø 28)	[kgcm ²]		2.700	2.700	2.700	2.700	2.700	2.700	2.700		
Moment of Inertia (≤ Ø 38)	[kgcm ²]		--	--	--	--	--	--	--		
Efficiency	[%]	*11	90								
Torsional Rigidity	[Nm/arc-min]	*12	31								
Maximum Torsional Backlash	[arc-min]	--	≤ 5								
Noise Level	[dB]	*13	71								
Protection Class		*15	IP54 (IP65)								
Ambient Temperature	[°C]		0-40								
Permitted Housing Temperature	[°C]	*16	90								
Weight	[kg]	*10	8.7								

- *1) At nominal input speed, service life is 20,000 hours
- *2) The maximum torque when starting or stopping operation
- *3) The maximum torque allowed under a stress situation (Permitted 1,000 times during service life)
- *4) The average input speed
- *5) The maximum intermittent input speed
- *6) This is the torque at no load applied on the input shaft. The input speed is 3,000 rpm for VRL 120
- *7) At this load and nominal input speed, service life will be 20,000 hours. (The radial load applied to the output side bearing)
- *8) At this load and nominal input speed, service life will be 20,000 hours. (The axial load applied to the output shaft center)
- *9) The maximum radial load that the reducer can accept
- *10) The maximum axial load that the reducer can accept
- *11) The efficiency at the nominal torque rating
- *12) This does not include the lost motion
- *13) Contact NIDEC-SHIMPO for the testing conditions and environment
- *14) IP65 (wash-down) is available as an option. Contact NIDEC-SHIMPO for more details and our food grade options
- *15) The weight may vary slightly between models

VRL

VRL-090 – 1-Stage Adapter Dimensions

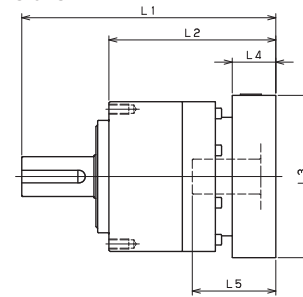

Model number	**: Adapter code	1-Stage					
		L1	L*	L2	L3	L4	L5
VRL-090-□-□-8** (Input shaft bore ≤ φ8)	AA-AC-AD-AF-AG-AL-AM-AN-AQ	--	--	--	--	--	--
	AB-AE-AH-AJ-AK	--	--	--	--	--	--
	BA-BB-BD-BE-BG-BH-BJ	--	--	--	--	--	--
	CA	--	--	--	--	--	--
VRL-090-□-□-14** (Input shaft bore ≤ φ14)	BA-BB-BD-BE-BF-BG-BH-BJ-BK-BP	143	126.5	97	□65	16.5	35
	BC-BH-BM-BN	148	126.5	102	□65	21.5	40
	CA-CC	143	126.5	97	□70	16.5	35
	DA-DB-DC-DD-DF-DH-DJ	143	126.5	97	□80	16.5	35
	EA-EB-EC-EF-EG-EK-EL	143	126.5	97	□90	16.5	35
	FA	143	126.5	97	□100	16.5	35
	FB	153	126.5	107	□100	26.5	45
VRL-090-□-□-19** (Input shaft bore ≤ φ19)	JA	158	126.5	112	□150	31.5	50
	DA-DB-DC	153	128	107	□80	25	50
	EB-ED	153	128	107	□90	25	50
	FA	153	128	107	□100	25	50
	FB	163	128	117	□100	35	60
	GA-GC-GH	158	128	112	□115	30	55
	GB-GD-GJ	153	128	107	□115	25	50
	GE-GF	163	128	117	□115	35	60
	HA	153	128	107	□130	25	50
	HB	168	128	122	□130	40	65
VRL-090-□-□-28** (Input shaft bore ≤ φ28)	HC-HD-HE	158	128	112	□130	30	55
	JA	163	128	117	□150	35	60
	JB	168	128	122	□150	40	65
	FA-FB-FC	170	135	124	□100	35	67
	FD-FE	165	135	119	□100	30	62
	GA-GB-GC-GD-GE-GF-GG-GH	170	135	124	□115	35	67
	HA-HC-HD	170	135	124	□130	35	67
	HB	180	135	134	□130	45	77
	HE	185	135	139	□130	50	82
	HF	165	135	119	□130	30	62
VRL-090-□-□-38** (Input shaft bore ≤ φ38)	JA-JB-JC-JF	170	135	124	□150	35	67
	JD	190	135	144	□150	55	87
	JE	180	135	134	□150	45	77

*1) Single reduction : 1/3~ 1/10 *2) Bushing will be inserted to adapt to motor shaft

For an explanation on the Adapter Flange Code, please turn to page 422.

A more comprehensive adapter flange offering can be found using the NIDEC-SHIMPO Online Selector Tool. The variety is constantly expanding and being updated on the Selector Tool. If you have any questions or need any support, contact NIDEC-SHIMPO.

VRL-090 – 2-Stage Adapter Dimensions

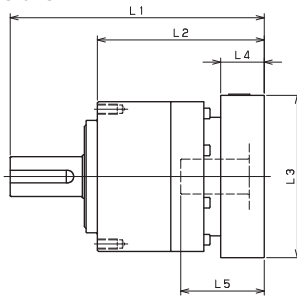

VRL

Model number	**: Adapter code	2-Stage					
		L1	L*	L2	L3	L4	L5
VRL-090-□-□-8** (Input shaft bore ≤ φ8)	AA-AC-AD-AF-AG-AL-AM-AN-AQ	160	144.5	114	□52	15.5	32
	AB-AE-AH-AJ-AK	165	144.5	119	□52	20.5	37
	BA-BB-BD-BE-BG-BH-BJ	160	144.5	114	□60	15.5	32
	CA	165	144.5	119	□70	20.5	37
VRL-090-□-□-14** (Input shaft bore ≤ φ14)	BA-BB-BD-BE-BF-BG-BH-BJ-BK-BP	165	148.5	119	□65	16.5	35
	BC-BH-BM-BN	170	148.5	124	□65	21.5	40
	CA-CC	165	148.5	119	□70	16.5	35
	DA-DB-DC-DD-DF-DH-DJ	165	148.5	119	□80	16.5	35
	EA-EB-EC-EF-EG-EK-EL	165	148.5	119	□90	16.5	35
	FA	165	148.5	119	□100	16.5	35
	FB	175	148.5	129	□100	26.5	45
	JA	180	148.5	134	□150	31.5	50
VRL-090-□-□-19** (Input shaft bore ≤ φ19)	DA-DB-DC	175	150	129	□80	25	50
	EB-ED	175	150	129	□90	25	50
	FA	175	150	129	□100	25	50
	FB	185	150	139	□100	35	60
	GA-GC-GH	180	150	134	□115	30	55
	GB-GD-GJ	175	150	129	□115	25	50
	GE-GF	185	150	139	□115	35	60
	HA	175	150	129	□130	25	50
	HB	190	150	144	□130	40	65
	HC-HD-HE	180	150	134	□130	30	55
	JA	185	150	139	□150	35	60
	JB	190	150	144	□150	40	65
VRL-090-□-□-28** (Input shaft bore ≤ φ28)	FA-FB-FC	194	159	148	□100	35	67
	FD-FE	189	159	143	□100	30	62
	GA-GB-GC-GD-GE-GF-GG-GH	194	159	148	□115	35	67
	HA-HC-HD	194	159	148	□130	35	67
	HB	204	159	158	□130	45	77
	HE	209	159	163	□130	50	82
	HF	189	159	143	□130	30	62
	JA-JB-JC-JF	194	159	148	□150	35	67
JD	214	159	168	□150	55	87	
JE	204	159	158	□150	45	n	

*1) Double reduction : 1/15~ 1/100 *2) Bushing will be inserted to adapt to motor shaft

For an explanation on the Adapter Flange Code, please turn to page 422.

A more comprehensive adapter flange offering can be found using the NIDEC-SHIMPO Online Selector Tool. The variety is constantly expanding and being updated on the Selector Tool. If you have any questions or need any support, contact NIDEC-SHIMPO.

VRL-120 – 1-Stage Specifications

Frame Size		120									
Stage		1-Stage									
Ratio	Unit	Note	3	4	5	6	7	8	9	10	
Nominal Output Torque	[Nm]	*1	120	120	180	180	180	180	120	120	
Maximum Output Torque	[Nm]	*2	225	330	330	330	330	330	225	225	
Emergency Stop Torque	[Nm]	*3	500	625	625	625	625	625	500	500	
Nominal Input Speed	[rpm]	*4	3000								
Maximum Input Speed	[rpm]	*5	6000								
No Load Running Torque	[Nm]	*14	1.30								
Permitted Radial Load	[N]	*6	1300	1500	1600	1700	1800	1900	1900	2000	
Permitted Axial Load	[N]	*7	1500	1700	1900	2000	2100	2300	2400	2500	
Maximum Radial Load	[N]	*8	4300								
Maximum Axial Load	[N]	*9	3900								
Moment of Inertia (≤Ø 14)	[kgcm ²]		--	--	--	--	--	--	--	--	
Moment of Inertia (≤ Ø 19)	[kgcm ²]		3.300	2.000	1.600	1.300	1.100	1.000	0.980	0.950	
Moment of Inertia (≤ Ø 28)	[kgcm ²]		5.300	4.100	3.600	3.300	3.200	3.100	3.000	3.000	
Moment of Inertia (≤ Ø 38)	[kgcm ²]		13.000	12.000	11.000	11.000	11.000	11.000	11.000	11.000	
Efficiency	[%]	*11	95								
Torsional Rigidity	[Nm/arc-min]	*12	31								
Maximum Torsional Backlash	[arc-min]		≤ 5								
Noise Level	[dB]	*13	71								
Protection Class		*15	IP54 (IP65)								
Ambient Temperature	[°C]		0-40								
Permitted Housing Temperature	[°C]	*16	90								
Weight	[kg]	*10	7.8								

VRL-120 – 2-Stage Specifications

Frame Size		120									
Stage		2-Stage									
Ratio	Unit	Note	15	16	20	25	28	30	35	40	
Nominal Output Torque	[Nm]	*1	120	180	180	180	180	120	180	180	
Maximum Output Torque	[Nm]	*2	225	330	330	330	330	225	330	330	
Emergency Stop Torque	[Nm]	*3	500	625	625	625	625	500	625	625	
Nominal Input Speed	[rpm]	*4	3000								
Maximum Input Speed	[rpm]	*5	6000								
No Load Running Torque	[Nm]	*14	0.42								
Permitted Radial Load	[N]	*6	2300	2300	2500	2700	2800	2900	3000	3200	
Permitted Axial Load	[N]	*7	3000	3100	3400	3700	3900	3900	3900	3900	
Maximum Radial Load	[N]	*8	4300								
Maximum Axial Load	[N]	*9	3900								
Moment of Inertia (≤Ø 14)	[kgcm ²]		0.430	0.480	0.400	0.380	0.440	0.290	0.370	0.280	
Moment of Inertia (≤ Ø 19)	[kgcm ²]		0.860	0.920	0.830	0.820	0.880	0.740	0.810	0.730	
Moment of Inertia (≤ Ø 28)	[kgcm ²]		2.800	2.900	2.800	2.800	2.800	2.700	2.700	2.700	
Moment of Inertia (≤ Ø 38)	[kgcm ²]		--	--	--	--	--	--	--	--	
Efficiency	[%]	*11	90								
Torsional Rigidity	[Nm/arc-min]	*12	31								
Maximum Torsional Backlash	[arc-min]		≤ 5								
Noise Level	[dB]	*13	71								
Protection Class		*15	IP54 (IP65)								
Ambient Temperature	[°C]		0-40								
Permitted Housing Temperature	[°C]	*16	90								
Weight	[kg]	*10	8.7								